

# Sustainable Mobility



# SUSTAINABLE MOBILITY

SHAMS TANVIR

**Mavs Open Press**

**Arlington**



Sustainable Mobility Copyright © 2024 by Shams Tanvir is licensed under a [Creative Commons Attribution-NonCommercial-ShareAlike 4.0 International License](https://creativecommons.org/licenses/by-nc-sa/4.0/), except where otherwise noted.

# CONTENTS

---

About the Publisher Mavs Open Press	vii
About This Project	viii
Preface	ix
About the Author	x
About the Institution	xi
Copyright	xii
Acknowledgements	xiii
Introduction And Learning Objectives	1
Chapter 1: The Basics of Sustainable Mobility	2
Chapter 2: Transportation and Climate Change	15
Chapter 3: Design of Bicycle Facilities	28
Chapter 4: Design of Pedestrian Facilities	39
Chapter 5: Energy Consumption and Emissions from Transportation	47
Chapter 6: Introduction to Zero Emissions Vehicles	66
Chapter 7: Design of Charging Infrastructure	82
Chapter 8: Shared Mobility and Automation	99
Chapter 9: Sustainable Freight	111
Links by Chapter	123
References	128
Image Credits	137
Derivative Notes	140
Errata and Versioning History Mavs Open Press	142



## ABOUT THE PUBLISHER

---

### MAVS OPEN PRESS

#### ABOUT MAVS OPEN PRESS

Creation of this resource was supported by [Mavs Open Press](#), operated by the University of Texas at Arlington Libraries (UTA Libraries). Mavs Open Press, operated by the [University of Texas at Arlington Libraries](#) (UTA Libraries), offers no-cost services for UTA faculty, staff, and students who wish to openly publish their scholarship. The Libraries' program provides human and technological resources that empower our communities to create or adapt open educational resources (OER). Course materials published by Mavs Open Press are openly licensed using Creative Commons licenses to allow for revision and reuse and are offered in various digital formats free of charge. Mavs Open Press also supports the publication of [open-access journals](#) authored and edited by UTA faculty, staff, and students.

#### ABOUT OER

OER are free teaching and learning materials that are licensed to allow for revision and reuse. They can be fully self-contained textbooks, videos, quizzes, learning modules, and more. OER are distinct from public resources in that they permit others to use, copy, distribute, modify, or reuse the content. The legal permission to modify and customize OER to meet the specific learning objectives of a particular course make them a useful pedagogical tool.

#### ABOUT PRESSBOOKS

[Pressbooks](#) is an open source, web-based authoring tool based on WordPress, and it is the primary tool that Mavs Open Press uses to create and adapt course materials. Pressbooks should not be used with Internet Explorer. The following browsers are best to use with Pressbooks:

- Firefox
- Chrome
- Safari
- Edge

#### CONTACT US

Information about [open education at UTA](#) is available online. Contact us at [library-open@listserv.uta.edu](mailto:library-open@listserv.uta.edu) for other inquiries related to UTA Libraries publishing services.

## ABOUT THIS PROJECT

---

The development of this textbook was made possible by the support of the U.S. Department of Education, which in January 2021 awarded the three-year funded project: **OERTransport: Enabling Transportation Planning Professional Advancement** (P116T200033) to *the University of Texas-Arlington (UTA)* in consortium with California Polytechnic State University (Cal Poly) and the University of South Florida (USF).

This open textbook is part of the [OERTransport](#) collection of six transportation planning OER textbooks and their respective graduate course implementation at each of the three collaborating universities. The creation of each textbook benefitted from an independent industry advisory board's review and the savvy contributions of each institution's OER librarians.

The contents of this textbook were developed under an Open Textbooks Pilot grant from the Fund for the Improvement of Postsecondary Education (FIPSE), U.S. Department of Education. However, those contents do not necessarily represent the policy of the Department of Education, and no endorsement by the Federal Government should be assumed.



## PREFACE

---

This textbook and OER material cover tools and basic knowledge required to prepare transportation engineers and planners to contribute towards a carbon-neutral mobility future. In addition, we will explore the potential for vehicle electrification, automation, connectivity, and ridesharing to reduce the carbon impacts of automobility. The textbook modules are intended to inform and teach students how to design streets for modes that have almost no carbon emissions. The goal of the textbook is to train engineering students on existing tools and policy levers that can be used to incorporate emerging transportation technologies in a sustainable, equitable, and efficient manner. The course is designed for graduate transportation engineering, and city and regional planning students. The undergraduate seniors will be able to absorb the materials given they have already taken fundamental courses on transportation engineering and planning, including traffic engineering and highway design.

## ABOUT THE AUTHOR

---

### **Shams Tanvir, Ph.D.**

Dr. Shams Tanvir is an assistant professor in the Department of Civil Engineering and Construction Engineering Management (CECEM) at California State University – Long Beach. Previously, he was an assistant professor at Cal Poly and a research faculty member at the Center for Environmental Research and Technology at the University of California Riverside. His research aims at the development and characterization of transportation technologies that minimize energy consumption and emissions while enhancing mobility efficiency and equity. Dr. Tanvir is a member of the Transportation Research Board committee on Highway Capacity and Quality of Service, and Transportation Air Quality and Greenhouse Gas Mitigation. He chairs the Sustainable Transportation Committee at the American Society of Civil Engineers (ASCE). Currently, he is leading projects sponsored by the US Department of Transportation, the California Air Resources Board (CARB), the US Department of Education, and the California Department of Transportation. Dr. Tanvir received his Ph.D. in Transportation Systems Engineering from North Carolina State University. He received a B.S. and M.S. in Civil Engineering from Bangladesh University of Engineering and Technology, Dhaka.

## ABOUT THE INSTITUTION

---

California Polytechnic State University (Cal Poly) is located in San Luis Obispo on California's Central Coast, about halfway between Los Angeles and San Francisco. Cal Poly was founded in 1901 and has been consistently named the best public, master's-level university in the West by U.S. News & World Report since the late 1990s. It is part of the 23-campus California State University system and is well-known for its learn-by-doing pedagogy.

## COPYRIGHT

---

*Sustainable Mobility* by Shams Tanvir is licensed under a Creative Commons, Attribution, NonCommercial, ShareAlike 4.0 International License, except where otherwise noted. ([CC BY NC SA](#))

## ACKNOWLEDGEMENTS

---

### US DEPARTMENT OF EDUCATION

- Stacey A. Slijepcevic, Ph.D., FIPSE Senior Program Manager/HIS STEM Senior Program Manager, U.S. Department of Education
- Kurrinn Cusumano-Abrams, MA, Education Program Specialist, Hispanic-Serving Institutions (HSI) Division, Program Lead, Open Textbooks Pilot (OTP) Program, U.S. Department of Education, Office of Postsecondary Education.

### PROJECT INDUSTRY ADVISORY BOARD

- Beth Alden, M.P., AICP, Executive Director, Hillsborough Metropolitan Planning Organization, Tampa, FL.
- Ann Foss, Ph.D., AICP, Planning and Programming Manager, Transportation Department, City of Arlington, TX.
- Brian Guenzel, MCRP, Senior Planner, City of Midlothian, TX.
- David L. Hutchinson, Executive Director of the Sarasota/Manatee, Metropolitan Planning Organization (MPO), Sarasota, FL.
- Muhammad A Khan, Ph.D., Transportation Planning and Urban Planning Specialist with the Government of Pakistan.
- John Liu, M.S., Deputy District Director, Maintenance and Operations, at Caltrans. Clovis, CA.
- David Weinreich, Ph.D., Postdoctoral Fellow in Urban Governance and Sustainable Transformation, University of Bergen, Norway.
- James Wood, Ph.D., Planner., Project Manager at the Dallas-Fort Worth International Airport.

### PROJECT DIRECTION

- Ivonne Audirac, Ph.D., Professor, City and Regional Planning Program and Associate Director for Education, Center for Transportation, Equity Decisions, and Dollars CTEDD, University of Texas at Arlington (UTA). OERTransport Project PI.
- Jay M. Rosenberger, Ph.D., Professor, Industrial Engineering, University of Texas at Arlington (UTA). OERTransport Project Co-PI.
- Amber Raley, M.A., Urban Planning and Public Policy Ph.D. Student, University of Texas at Arlington (UTA). OERTransport Project Co-PI.

## **PROOFREADERS AND EDITORS**

- Dr. Anurag Pande, Ph.D in Civil Engineering (Transportation).
- Dr. Ahmed Farid, Ph.D in Civil Engineering.
- Peyton Ratto, M.S./MCRP, Civil Engineering and City and Regional Planning with a specialization in Transportation Planning.
- Anne Regan, M.A., English, Creative Commons (CC) License Certified.
- Morgan White, M.A., English.

## **PROJECT OER LIBRARIANS**

- Michelle Reed, M.S.I.S.
- Katherine Chapline, M.S.
- Jessica McClean, M.S.I.S.
- UTA Libraries OER Department Staff, University of Texas at Arlington (UTA)

## **INSTITUTION OER SPECIALIST**

- Anne M. Regan, M.A., English, Creative Commons (CC) License Certified.

## **PROJECT TRAINING IN COURSE DESIGN**

- Ann M.L. Cavallo, Ph.D. and Dr. Andrew M. Clark, Ph.D. UTA, Center for Research Excellence in Teaching and Learning (CTRL), University of Texas at Arlington (UTA)

## **OTHER PROJECT PERSONNEL**

- Liana Saker, Undergraduate Research Assistant, Cal Poly

## **OTHER ACKNOWLEDGEMENTS**

- US Department of Education for funding this effort
- The support of the PI and her team at UTA
- Collaborators at USF and Cal Poly for sharing their textbook templates and knowledge
- Ms. Anne Regan, OER Coordinator at Cal Poly, for supporting the development of OER material
- Ms. Morgan White for helping transfer the content of the OER into Pressbooks

## **ABOUT THE COVER**

Anne Regan, OER Specialist Cal Poly, San Luis Obispo, designed the cover for this OER. The image used "[Bike Group & Bus on 3rd Ave](#)" by SDOT Photos is licensed under [CC BY-NC 2.0](#).

## INTRODUCTION AND LEARNING OBJECTIVES

---

The purpose of this book is to prepare students to contribute towards a carbon-neutral mobility future. A major part of this book focuses on designing streets for modes that have almost no carbon emissions: walking and cycling, with an emphasis on cycling, since bicycle trips have the greatest potential to replace car trips. The second part of the book discusses different pathways for vehicle electrification and sharing to reduce the carbon impacts of automobility. The third part of the book introduces students to actionable tools and policies to shape transportation choices that prevent climate change.

### **Learning Objectives:**

By following the lessons outlined in the textbook, students will be able to:

- **Explain** the concept of Sustainable Mobility and **list** the drivers of transportation-related climate change.
- **Design** bike facilities – calculate *Level of Service* (LOS) for bike facilities, understand the safety features, design bike and scooter share facilities, intersection control for bicycle.
- **Design** pedestrian facilities – calculate LOS, intersection management for pedestrians, conceptualize and implement components of complete streets.
- **Estimate** energy consumption and emissions from automobility.
- **Explain** the concepts of light-duty and heavy-duty vehicle electrification.
- **Analyze and design** transportation and charging infrastructure in alignment with expanding electrification needs
- **Formulate** policies for alternate fuel vehicles and shared mobility.
- **Emphasize** the needs of disadvantaged communities and environmental justice.
- **Calculate** the energy and environmental footprints of the existing scenario and the proposed improvements.

## CHAPTER 1: THE BASICS OF SUSTAINABLE MOBILITY

---

Sustainability has a broad definition and it varies from one discipline to another. This textbook defines sustainable mobility from the perspective of transportation engineering. We will train students to plan, design, operate, and maintain transportation-related infrastructure with the lens of sustainability as the primary focus. The textbook was designed to use with a course that aims to teach students the current tools and technologies that have already been proven to reduce energy consumption and emissions from the transportation system. At the same time, we will introduce students to a blueprint to characterize, enhance, and integrate transportation technologies into transportation systems. This chapter lays down the overarching concept of this book.

### CHAPTER OVERVIEW

The term “Sustainable Mobility” can be broken down into the terms “sustainable” and “mobility”. While sustainability has been defined in the literature in many ways, the meaning of sustainability in terms of mobility has specific nuances. In this chapter, we will start with the broader definition of sustainability. We will drill further down into specific transportation strategies that can improve the sustainability of the transportation system.

#### Chapter Topics

1. [Pillars of sustainability](#)
2. [Sustainable transportation](#)
3. [Reasons for unsustainable transportation](#)
4. [Sustainable mobility strategies](#)

### Learning Objectives

At the end of the chapter, the reader should be able to do the following:

- Summarize the three pillars of sustainability.
- Acquire a basic facility for using the IPAT equation.
- Identify the strategies to promote sustainability in the transportation sector.
- Classify different metrics of sustainable transportation.
- Explain why the automobile-based system of transportation is unsustainable in terms of inputs, outputs, and social impacts
- Explain why transportation is a derived demand and how making transportation sustainable depends on land use as well as vehicles and infrastructure.



- Differentiate between accessibility and mobility by comparing how they are currently treated by our transportation system
- Analyze how a more sustainable system might address accessibility and mobility.

## SUSTAINABILITY

Sustainability is derived from two Latin words: *sus* which means up and *tenere* which means to hold. In its modern form it is a concept born out of the desire of humanity to continue to exist on planet Earth for a very long time, perhaps the indefinite future. Sustainability is, hence, essentially and almost literally about holding up human existence. Possibly, the most succinct articulation of the issue can be found in the Report of the World Commission on Environment and Development. The report entitled “Our Common Future” primarily addressed the closely related issue of Sustainable Development. The report, commonly known as the Brundtland Report after the Commission Chair Gro Harlem Brundtland, stated that “Humanity has the ability to make development sustainable to ensure that it meets the needs of the present without compromising the ability of future generations to meet their own needs.” Following the concept of Sustainable Development, the commission went on to add “Yet in the end, **sustainable development** is not a fixed state of harmony, but rather a process of change in which the exploitation of resources, the direction of investments, the orientation of technological development, and institutional change are made consistent with future as well as present needs. We do not pretend that the process is easy or straightforward. Painful choices have to be made. Thus, in the final analysis, sustainable development must rest on political will.” Sustainability and the closely related concept of Sustainable Development are, therefore, very human constructs whose objective is to insure the very survival of humanity in a reasonably civilized mode of existence.

## PILLARS OF SUSTAINABILITY

*Achieving the goals of Sustainability requires a balance among three different bottom lines* (shown in Figure 1.1), which are linked in very intricate ways. For example, the Great Recession of 2008 resulted in a temporary decrease of carbon emissions. However, tentative improvements in the economy have been accompanied by proportionally larger increments in emissions. Stricter regulations on the mining industry in the developed world resulted in mass migration of extractive industries to the developing world, with a net increment in environmental degradation and larger losses of environmental resources.

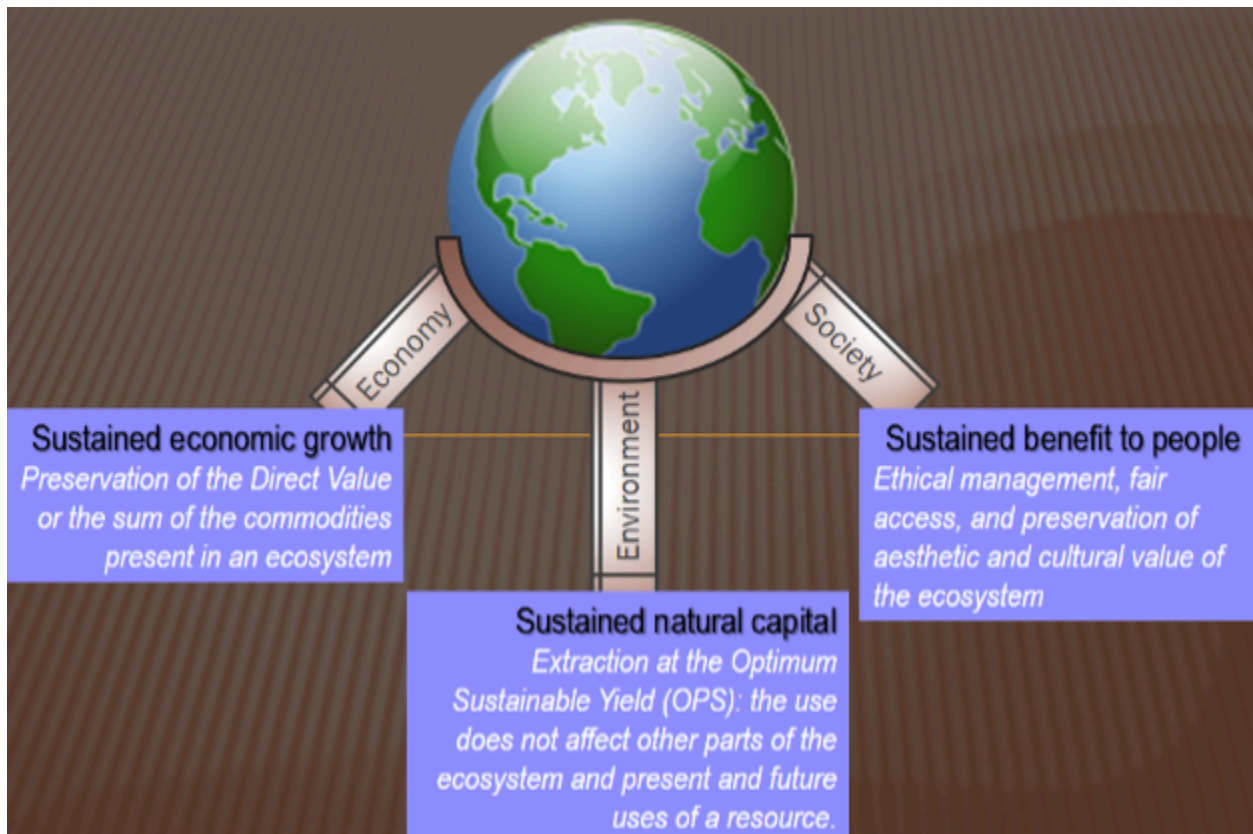

Figure 1.1: [Three pillars of sustainability](#) by Neyda Abreu under [CC BY-NC-SA 4.0](#)

The Environmental Bottom Line limits the extraction and harvesting to levels at or below the Optimal Sustainable Yield and it addresses critical environmental concerns:

1. *Emissions*. Minimize emission from fossil fuels and the impact of these emissions on global climate.
2. *Resources*. Reverse the loss of environmental resources.
3. *Biodiversity*. Decrease the rate of decline of biodiversity.

The Social Bottom Line addresses the ethical management of resources, issues of social stability, and the preservation of aesthetic and cultural values. Social stability requires universal access to:

**Food.** Feeding the world's population, which is projected to reach over 9 billion by 2050, requires a large increment of agricultural output. This is particularly important in the developing world, where production is limited and most of the population growth is predicted to occur. However, modern agricultural methods require vast losses of wild lands, drastic changes in ecosystems, and the introduction of large amounts of fertilizer and pesticides.

**Safe drinking water and basic sanitation.** Access to water that is microbially, chemically and physically safe for human and animal consumption, sanitation and hygiene remains a challenge in the developing world. In addition, depletion and pollution of surface and ground waters are an increasing concern in many developed nations including the United States.

The Economic Bottom Line aims at preserving the Direct Value of commodities present in an ecosystem. Sustainable economies are focused on curbing poverty and incentivizing fair trade.

## THE IPAT EQUATION

As attractive as the concept of sustainability may be as a means of framing our thoughts and goals, its definition is rather broad and difficult to work with when confronted with choices among specific courses of action. Here we introduce one general way to begin to apply sustainability concepts: the IPAT equation.

As is the case for any equation, IPAT expresses a balance among interacting factors. It can be stated as

Equation:

$$I = P \times A \times T$$

where I represents the impacts of a given course of action on the environment, P is the relevant human population for the problem at hand, A is the level of consumption per person, and T is impact per unit of consumption. Impact per unit of consumption is a general term for technology, interpreted in its broadest sense as any human-created invention, system, or organization that serves to either worsen or uncouple consumption from impact. The equation is not meant to be mathematically rigorous; rather it provides a way of organizing information for a “firstorder” analysis.

Suppose we wish to project future needs for maintaining global environmental quality at present day levels for the mid-twenty-first century. For this we need to have some projection of human population (P) and an idea of rates of growth in consumption (A).

The global population in 2050 will grow from the current 8 billion to about 9.2 billion, an increase of 35%. Global GDP (Gross Domestic Product, one measure of consumption) varies from year to year but, using an annual growth rate of about 3.5% seems historically accurate (growth at 3.5%, when compounded for forty years, means that the global economy will be four times as large at mid-century as today).

Thus if we wish to maintain environmental impacts (I) at their current levels, then

Equation:

$$P_{2023} \times A_{2023} \times T_{2023} = P_{2050} \times A_{2050} \times T_{2050}$$

Or

Equation:

$$\frac{T_{2050}}{T_{2023}} = \frac{P_{2023}}{P_{2050}} \times \frac{A_{2023}}{A_{2050}} = \frac{1}{1.35} \times \frac{1}{4} = \frac{1}{5.4}$$

This means that just to maintain current environmental quality in the face of growing population and levels of affluence, our technological decoupling will need to reduce impacts by about a factor of five. So, for instance, many recently adopted “climate action plans” for local regions and municipalities, such as the Chicago Climate Action Plan, typically call for a reduction in greenhouse gas emissions (admittedly just one impact measure) of eighty percent by mid-century. The means to achieve such reductions, or even whether or not they are necessary, are matters of intense debate; where one group sees expensive remedies with little demonstrable return, another sees opportunities for investment in new technologies, businesses, and employment sectors, with collateral improvements in global and national well-being.

## WHAT IS SUSTAINABLE TRANSPORTATION?

Transportation is a tricky thing to analyze in the context of sustainability. It consists in part of the built environment: the physical infrastructure of roads, runways, airports, bridges, and rail lines that

makes it possible for us to get around. It also consists in part of individual choices: what mode we use to get around (car, bus, bike, plane, etc.), what time of day we travel, how many people we travel with, etc. Finally, it also is made up of institutions: federal and state agencies, oil companies, automobile manufacturers, and transit authorities, all of whom have their own goals and their own ways of shaping the choices we make.

Most importantly, transportation is complicated because it's what is called a **derived demand**. With the exception of joyriding or taking a walk or bicycle ride for exercise, very rarely are we traveling just for the sake of moving. We're almost always going from Point A to Point B. What those points are—home, work, school, shopping—and where they're located—downtown, in a shopping mall, near a freeway exit—influence how fast we need to travel, how much we can spend, what mode we're likely to take, etc. The demand for transportation is derived from other, non-transportation activities. So in order to understand transportation sustainability, we have to understand the spatial relationship between where we are, where we want to go, and the infrastructure and vehicles that can help get us there.

Is our current transportation system in the U.S. sustainable? In other words, can we keep doing what we're doing indefinitely? The answer is clearly no, according to professional planners and academics alike. There are three main limitations: energy input, emissions, and social impacts (Black, 2010).

### **Energy Inputs**

The first reason that our current transportation system is unsustainable is that the natural resources that power it are finite. The theory of peak oil developed by geologist M. King Hubbert suggests that because the amount of oil in the ground is limited, at some point in time there will be a maximum amount of oil being produced (Deffeyes, 2002). After we reach that peak, there will still be oil to drill, but the cost will gradually rise as it becomes a more and more valuable commodity. The most reliable estimates of the date of peak oil range from 2005 to 2015, meaning that we've probably already passed the point of no return. New technologies do make it possible to increase the amount of oil we can extract, and new reserves, such as the oil shale of Pennsylvania and the Rocky Mountains, can supply us for some years to come (leaving aside the potential for environmental and social damage from fully developing these sites). However, this does not mean we can indefinitely continue to drive gasoline-powered vehicles as much as we currently do.

Scientists are working on the development of alternative fuels such as biofuels or hydrogen, but these have their own limitations. For example, a significant amount of land area is required to produce crops for biofuels; if we converted every single acre of corn grown in the U.S. to ethanol, it would provide 10% of our transportation energy needs. Furthermore, growing crops for fuel rather than food has already sparked price increases and protests in less-developed countries around the world (IMF, 2010). Is it fair to ask someone living on less than two dollars a day to pay half again as much for their food so we can drive wherever and whenever we want?

### **Emissions or Outputs**

The engine of the typical automobile or truck emits all sorts of noxious outputs. Some of them, including sulfur dioxides, carbon monoxide, and particulate matter, are directly harmful to humans; they irritate our lungs and make it hard for us to breathe. (Plants are damaged in much the same way). These emissions come from either impure fuel or incomplete burning of fuel within an engine. Other

noxious outputs cause harm indirectly. Nitrous oxides (the stuff that makes smog look brown) from exhaust, for example, interact with oxygen in the presence of sunlight (which is why smog is worse in Los Angeles and Houston), and ozone also damages our lungs.

Carbon dioxide, another emission that causes harm indirectly, is the most prevalent greenhouse gas (GHG), and transportation accounts for 23% of the CO<sub>2</sub> generated in the U.S. This is more than residential, commercial, or industrial users, behind only electrical power generation (DOE, 2009). Of course, as was explained above, transportation is a derived demand, so to say that transportation itself is generating carbon emissions is somewhat misleading. The distance between activities, the modes we choose to get between them, and the amount of stuff we consume and where it is manufactured, all contribute to that derived demand and must be addressed in order to reduce GHG emissions from transportation.

### **Social Impacts**

If the definition of sustainability includes meeting the needs of the present population as well as the future, our current transportation system is a failure. Within most of the U.S., lack of access to a personal automobile means greatly reduced travel or none at all. For people who are too young, too old, or physically unable to drive, this means asking others for rides, relying heavily on under-funded public transit systems, or simply not traveling. Consider, for example, how children in the U.S. travel to and from school. In 1970, about 50% of school-aged children walked or biked to school, but by 2001, that number had dropped to 15% (Appleyard, 2005). At the same time that childhood obesity and diabetes are rising, children are getting less and less exercise, even something as simple as walking to school. Furthermore, parents dropping off their children at school can increase traffic levels by 20 to 25%, not just at the school itself, but also throughout the town in question (Appleyard, 2005). At the other end of the age spectrum, elderly people may be functionally trapped in their homes if they are unable to drive and lack another means of getting to shopping, health care, social activities, etc. Finally, Hurricane Katrina made it clear that access to a car can actually be a matter of life or death: the evacuation of New Orleans worked very well for people with cars, but hundreds died because they didn't have the ability to drive away.

Another serious social impact of our transportation system is traffic accidents. Road accidents and fatalities are accepted as a part of life, even though 42,000 people die every year on the road in the U.S. This means that cars are responsible for more deaths than either guns, drugs, or alcohol (Xu et al., 2010). On the bright side, there has been a steady reduction in road fatalities over the last few decades, thanks to a combination of more safety features in vehicles and stricter enforcement and penalties for drunk or distracted drivers. Nevertheless, in many other countries around the world, traffic accidents are in the top ten or even top five causes of death, leading the World Health Organization to consider traffic accidents a public health problem.

An additional problem with our current unsustainable transportation system is that much of the rest of the world is trying to emulate it. The U.S. market for cars is saturated, meaning that basically everyone who can afford or is likely to own a car already has one. This is why automobile manufacturers vie so fiercely with their advertising, because they know they are competing with each other for pieces of a pie that's not getting any bigger. In other countries such as China and India, though, there are literally billions of people who do not own cars. Now that smaller, cheaper vehicles like the Tata are entering these markets, rates of car ownership are rising dramatically. While the same problems with resources, emissions, and social impacts are starting to occur in the developing world,

there are also unique problems. These include a lack of infrastructure, which leads to monumental traffic jams; a need for sharing the road with pedestrians and animals; and insufficient regulation to keep lead and other harmful additives out of gasoline and thus the air.

## WHAT WOULD MAKE TRANSPORTATION SUSTAINABLE?

The circular answer to the question is to meet our current transportation needs without preventing future generations from meeting theirs. We can start by using fewer resources or using the ones we have more efficiently. One way to do this is by increasing the efficiency of new vehicles as they are manufactured. Since 1981, automotive engineers have figured out how to increase horsepower in the average American light-duty vehicle (cars and SUVs) by 60%, but they haven't managed to improve miles per gallon at all (see Figure World Oil Production – History and Projections). As gas prices continue to rise on the downside of the oil peak, consumers are already demanding more fuel-efficient cars, and federal legislation is moving in this direction to raise the Corporate Average Fuel Economy (CAFE) standards.

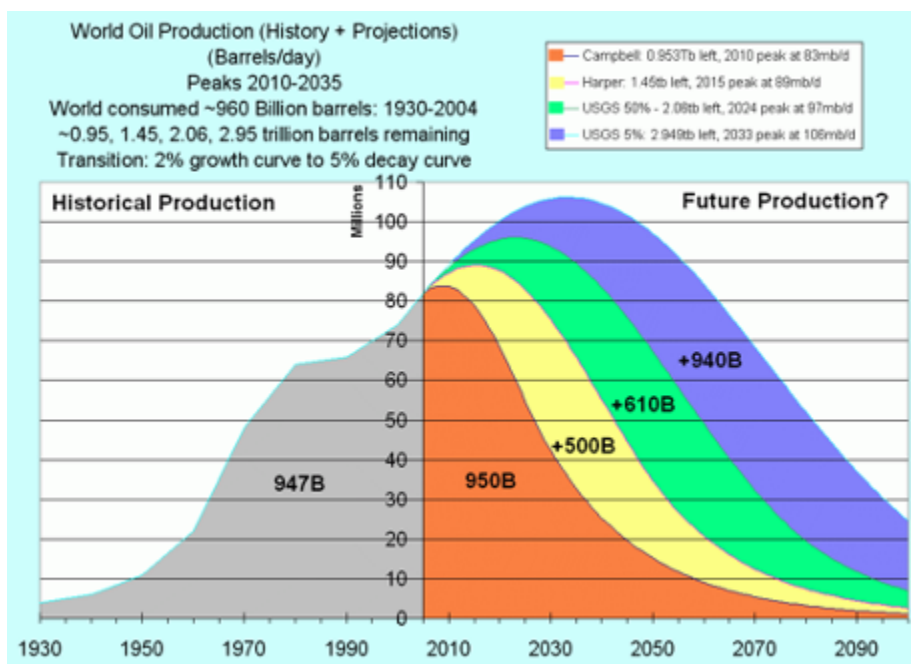

Figure 1.2: [World Oil Production- History and Projections](#) by Tom Ruen is under the Public Domain via Wikimedia Commons

However, simply producing more fuel-efficient vehicles is not sufficient when we consider the **embodied energy** of the car itself. It takes a lot of energy to make a car, especially in the modern “global assembly line,” where parts come from multiple countries for final assembly, and that energy becomes “embodied” in the metal, plastic, and electronics of the car. A study in Europe found that unless a car is over 20 years old, it does not make sense to trade it in for a more efficient one because of this embodied energy (Usón et al., 2011). Most Americans trade in their cars after about a third of that time. A related concept is true for electric cars. In their daily usage, they generate zero carbon emissions, but we should also consider the source of power used to recharge the vehicle. In most parts of the U.S., this is coal, and therefore the emissions savings are only about 30% over a traditional vehicle (Marsh, 2011).

If transportation is a derived demand, another way to meet our current transportation needs is by

changing the demand. There are two related aspects to this. First, there is a clear causal link between having more transportation infrastructure and more miles traveled on that infrastructure, and greater economic growth. This is true between regions of the world, between individual countries, and between people and regions within countries. This causal connection has been used as a reason to finance transportation projects in hundreds of different contexts, perhaps most recently in the American Reinvestment and Recovery Act that distributed federal funds to states and localities to build infrastructure in the hopes that it would create jobs. Policymakers, businesspeople, and citizens therefore all assume that we need more transportation to increase economic growth.

However, it is also true that more transportation does not automatically mean more economic growth: witness the state of West Virginia, with decades' worth of high-quality road infrastructure bestowed upon it by its former Senator Robert Byrd, but still at the bottom of economic rankings of states. Furthermore, at some point a country or region gains no significant improvements from additional infrastructure; they have to focus on making better use of what they already have instead. We therefore need to decouple economic growth from transportation growth (Banister and Berechman, 2001). We can substitute telecommunication for travel, work at home, or shop online instead of traveling to a store (although the goods still have to travel to our homes, this is more efficient than each of us getting in our own cars). We can produce the goods we use locally instead of shipping them halfway around the world, creating jobs at home as well as reducing resource use and emissions. All of these options for decoupling are ways to reduce the demand for transportation without also reducing the benefits from the activities that create that demand.

The other way to think about changing the derived demand of transportation is via the concepts of **accessibility** and **mobility**. Mobility is simply the ability to move or to get around. We can think of certain places as having high accessibility: at a major intersection or freeway exit, a train station, etc. Company headquarters, shopping malls, smaller businesses alike decide where to locate based on this principle, from the gas stations next to a freeway exit to the coffee shop next to a commuter rail station. At points of high accessibility, land tends to cost more because it's easier for people to get there and therefore more businesses or offices want to be there. This also means land uses are usually denser: buildings have more stories, people park in multi-level garages instead of surface lots, etc.

We can also define accessibility as our own ability to get to the places we want: where we shop, work, worship, visit friends or family, see a movie, or take classes. In either case, accessibility is partially based on what the landscape looks like—width of the roads, availability of parking, height of buildings, etc.—and partially on the mode of transportation that people have access to. If a person lives on a busy four-lane road without sidewalks and owns a car, most places are accessible to him. Another person who lives on that same road and doesn't have a car or can't drive might be literally trapped at home. If her office is downtown and she lives near a commuter rail line, she can access her workplace by train. If her office is at a major freeway intersection with no or little transit service, she has to drive or be driven.

Unfortunately, in the U.S. we have conflated accessibility with mobility. To get from work to the doctor's office to shopping to home, we might have to make trips of several miles between each location. If those trips are by bus, we might be waiting for several minutes at each stop or making many transfers to get where we want to go, assuming all locations are accessible by transit. If those trips are by car, we are using the vehicle for multiple short trips, which contributes more to air pollution than a single trip of the same length. Because of our land use regulations, which often segregate residential, retail, office, and healthcare uses to completely different parts of a city, we have

no choice but to be highly mobile if we want to access these destinations. John Urry has termed this automobility, the social and economic system that has made living without a car almost impossible in countries like the US and the UK (2004).

So how could we increase accessibility without increasing mobility? We could make it possible for mixed uses to exist on the same street or in the same building, rather than clustering all similar land uses in one place. For example, before a new grocery store opened in the student neighborhood adjacent to the University of Illinois campus in Champaign, people living there had to either take the bus, drive, or get a friend to drive them to a more distant grocery store. Residents of Campustown had their accessibility to fresh produce and other products increase when the new grocery store opened, although their mobility may have actually gone down. In a large scale example, the Los Angeles Metropolitan Transit Authority (MTA) was sued in the 1990s for discriminating against minorities by pouring far more resources into commuter rail than into buses. Commuter rail was used mainly by white suburbanites who already had high levels of accessibility, while the bus system was the only means of mobility for many African American and Hispanic city residents, who had correspondingly less accessibility to jobs, shopping, and personal trips. The courts ruled that the transit authority was guilty of racial discrimination because they were providing more accessibility for people who already had it at the expense of those who lacked it. The MTA was ordered to provide more, cleaner buses, increase service to major job centers, and improve safety and security. More sustainable transportation means ensuring equitable accessibility — not mobility — for everyone now and in the future.

## STRATEGIES FOR SUSTAINABLE TRANSPORTATION

How do we go about making transportation more sustainable? There are three main approaches: inventing new technologies, charging people the full costs of travel, and planning better so we increase accessibility but not mobility.

### **New Technology**

This is the hardest category to rely on for a solution, because we simply can't predict what might be invented in the next five to fifty years that could transform how we travel. The jet engine totally changed air travel, making larger planes possible and increasing the distance those planes could reach without refueling, leading to the replacement of train and ship travel over long distances. However, the jet engine has not really changed since the 1960s. Is there some new technology that could provide more propulsion with fewer inputs and emissions? It's possible. But at the same time, it would be unreasonable to count on future inventions magically removing our sustainability problems rather than working with what we already have.

Technology is more than just machines and computers, of course; it also depends on how people use it. When the automobile was first invented, it was seen as a vehicle for leisure trips into the country, not a way to get around every day. As people reshaped the landscape to accommodate cars with wider, paved roads and large parking lots, more people made use of the car to go to work or shopping, and it became integrated into daily life. The unintended consequences of technology are therefore another reason to be wary about relying on new technology to sustain our current system.

### **Charge Fuel Costs**

The economist Anthony Downs has written that traffic jams during rush hour are a good thing,



because they indicate that infrastructure is useful and a lot of people are using it (Downs, 1992). He also notes that building more lanes on a highway is not a solution to congestion, because people who were staying away from the road during rush hour (by traveling at different times, along different routes, or by a different mode) will now start to use the wider road, and it will become just as congested as it was before it was widened. His point is that the road itself is a resource, and when people are using it for free, they will overuse it. If instead, variable tolls were charged depending on how crowded the road was—in other words, how much empty pavement is available—people would choose to either pay the toll (which could then be invested in alternative routes or modes) or stay off the road during congested times. The point is that every car on the road is taking up space that they aren't paying for and therefore slowing down the other people around them; charging a small amount for that space is one way of recovering costs.

Traffic congestion is an example of what economists call externalities, the costs of an activity that aren't paid by the person doing the activity. Suburbanites who drive into the city every day don't breathe the polluted air produced by their cars; urban residents suffer that **externality**. People around the country who use gasoline derived from oil wells in the Gulf of Mexico didn't experience oil washing up on their beaches after the BP disaster in 2010. By charging the full cost of travel via taxes on gas or insurance, we could, for example, pay for children's hospitalization for asthma caused by the cars speeding past their neighborhoods. Or we could purchase and preserve wetland areas that can absorb the floodwaters that run off of paved streets and parking lots, keeping people's basements and yards drier. Not only would this help to deal with some of the externalities that currently exist, but the higher cost of gas would probably lead us to focus on accessibility rather than mobility, reducing overall demand.



Figure 1.3: [Freeway Traffic by User Minesweeper via Wikimedia Commons](#) is under the following Creative Commons license: [CC-BY-SA-3.0](#)

### Planning Better for Accessibility

The other way we can produce more sustainable transportation is to plan for accessibility, not

mobility. Many transportation planners say that we've been using the predict and provide model for too long. This means we assume nothing will change in terms of the way we travel, so we simply predict how much more traffic there is going to be in the future and provide roads accordingly. Instead, we should take a deliberate and decide approach, bringing in more people into the planning process and offering different options besides more of the same. Some of the decisions we can make to try and change travel patterns include installing bike lanes instead of more parking, locating retail development next to housing so people can walk for a cup of coffee or a few groceries, or investing in transit instead of highways.

For example, the school district in Champaign, Illinois, is considering closing the existing high school next to downtown, to which many students walk or take public transit, and replacing it with a much larger facility on the edge of town, to which everyone would have to drive or be driven. The new site would require more mobility on the part of nearly everyone, while many students and teachers would see their accessibility decrease. As gas prices continue to rise, it will cost the school district and parents more and more to transport students to and from school, and students will be more likely to drive themselves if they have access to a car and a driver's license. Putting the new school in a more accessible location or expanding the existing one would keep the school transportation system from becoming less sustainable.

You may have noticed that these proposed changes to increase transportation sustainability aren't really things that one person can do. We can certainly make individual choices to drive less and walk or bike more, to buy a more fuel-efficient car, or to use telecommunications instead of transportation. In order to make significant changes that can reduce overall energy usage and emissions production, however, the system itself has to change. This means getting involved in how transportation policy is made, maybe by attending public meetings or writing to city or state officials about a specific project. It means contacting your Congressional representatives to demand that transportation budgets include more money for sustainable transportation modes and infrastructure. It means advocating for those who are disadvantaged under the current system. In means remembering that transportation is connected to other activities, and that focusing on how the demand for transportation is derived is the key to making and keeping it sustainable.

### Key Takeaways

- Achieving the goals of Sustainability requires a balance among three different bottom lines – economy (profit), environment (planet), and society (people).
- The demand for transportation is derived from other, non-transportation activities.
- There are three major dimensions of unsustainable transportation- dependence on non-renewable fuel, emissions of deleterious materials, and social impacts or externalities such as congestion, crashes, etc.
- More sustainable transportation means ensuring equitable accessibility — not mobility — for everyone now and in the future.
- There are three main approaches to increase transportation sustainability: inventing new technologies, charging people the full costs of travel, and planning for multimodal accessibility.

## Self-Test



An interactive H5P element has been excluded from this version of the text. You can view it online here: <https://uta.pressbooks.pub/sustainablemobility/?p=29#h5p-1>

### GLOSSARY: KEY TERMS

**Accessibility:** In transportation, a measure of the ease with which people are able to get places they want or need to go.

**Derived demand:** Demand for a good or service that comes not from a desire for the good or service itself, but from other activities that it enables or desires it fulfills.

**Embodied energy:** The sum of all energy used to produce a good, including all of the materials, processes, and transportation involved.

**Externality:** Cost of an activity not paid by the person doing the activity.

**Mobility:** The ability to move or to get around.

**Sustainable development:** Development that meets the needs of the present without compromising the ability of future generations to meet their own needs.

### MEDIA ATTRIBUTIONS

- Figure 1.1: [Three pillars of sustainability](#) by Neyda Abreu is under the following Creative Commons license: [CC BY-NC-SA 4.0](#)
- Figure 1.2: [World Oil Production- History and Projections](#) by Tom Ruen is under the Public Domain via Wikimedia Commons
- Figure 1.3: [Freeway Traffic by User Minesweeper via Wikimedia Commons](#) is under the following Creative Commons license: [CC-BY-SA-3.0](#)

### REFERENCES

- Appleyard, B. S. 2005. Livable Streets for School Children: How Safe Routes to School programs can improve street and community livability for children. National Centre for Bicycling and Walking Forum, available online: [https://www.safetylit.org/citations/index.php?fuseaction=citations.viewdetails&citationIds\[\]=citjournalarticle\\_476088\\_9](https://www.safetylit.org/citations/index.php?fuseaction=citations.viewdetails&citationIds[]=citjournalarticle_476088_9)
- Banister, D. and Berechman, Y. 2001. Transport investment and the promotion of economic growth. *Journal of Transport Geography* 9:3, 209-218.

- Black, W. 2010. Sustainable Transportation: Problems and Solutions. New York: Guilford Press.
- Deffeyes, K. 2002. Hubbert's Peak: The Impending World Oil Shortage. Princeton, NJ: Princeton University Press.
- DOE (Department of Energy). 2009. Emissions of greenhouse gases report. DOE/EIA-0573, available online: <http://www.eia.doe.gov/oiaf/1605/ggrpt/carbon.html>
- Downs, A. 1992. Stuck in Traffic: Coping With Peak-Hour Traffic Congestion. Washington, DC: Brookings Institution Press.
- IMF (International Monetary Fund). 2010. Impact of high food and fuel prices on developing countries. Available online: <http://www.imf.org/external/np/exr/faq/ffpfaqs.htm>
- Marsh, B. 2011. Kilowatts vs. Gallons. *New York Times*, May 28. Available online: <http://www.nytimes.com/interactive/2011/05/29/weekinreview/volt-graphic.html?ref=weekinreview>
- Report of the World Commission on Environment and Development: Our Common Future. 1987. [www.un-documents.net/wced-ocf.htm](http://www.un-documents.net/wced-ocf.htm).
- UPI (United Press International). 2011. Global biofuel land area estimated. Available online: [http://www.upi.com/Science\\_News/2011/01/10/Global-biofuel-land-area-estimated/UPI-97301294707088/](http://www.upi.com/Science_News/2011/01/10/Global-biofuel-land-area-estimated/UPI-97301294707088/)
- Urry, J., 2004. The 'System' of Automobility. *Theory Culture and Society* 21:4-5, 25-39.
- Usón, A.A., Capilla, A.V., Bribián, I.Z., Scarpellini, S. and Sastresa, E.L. 2011. Energy efficiency in transport and mobility for an eco-efficiency viewpoint. *Energy* 36:4, 1916-23.
- Xu, J., Kochanek, K., Murphy, S., and Tejada-Vera, B. 2010. Deaths: Final Data for 2007. National Vital Statistics Reports, 58:19, available online: [http://www.cdc.gov/NCHS/data/nvsr/nvsr58/nvsr58\\_19.pdf](http://www.cdc.gov/NCHS/data/nvsr/nvsr58/nvsr58_19.pdf)

#### ATTRIBUTIONS

- Foundations in Sustainability Systems (EME 504) by Neyda Abreu is licensed under [CC BY-NC-SA 4.0](https://creativecommons.org/licenses/by-nc-sa/4.0/)
- [Sustainability: A Comprehensive Foundation](https://www.foundationsin.org/) by Tom Theis and Jonathan Tomkin is licensed under [CC BY 4.0](https://creativecommons.org/licenses/by/4.0/)

## CHAPTER 2: TRANSPORTATION AND CLIMATE CHANGE

---

### CHAPTER OVERVIEW

In this chapter, we specifically focus on the carbon emissions aspects of transportation policies, technologies, and investments. We start with the historical backdrop of the broader discussion on climate change. Then, we narrow down the discussion in the realm of transportation. Broadly, this chapter classifies the actions to be taken in the transportation sector to mitigate climate change as follows – short term (1-10 years), medium term (11- 30 years), and longer term (30+ years). Within each block, the actions are classified in (a) steps that reduce travel (b) increase efficiency (c) change the energy pathways (d) reduce exposure or increase resiliency.

In October of 2018, the Intergovernmental Panel on Climate Change (IPCC) released the Special Report on Global Warming of 1.5°C. The IPCC report found that any increase in average global temperatures would have negative health and economic impacts on people throughout the world. They also found that limiting global warming to temperature increases of no more than 1.5°C above pre-industrial levels could reduce the number of people who would experience those impacts by up to several hundred million. In order to limit temperature increases to 1.5°C above pre-industrial levels, we would need to reduce human-generated carbon emissions by 45 percent over the next decade or so, and by 100 percent by 2050.

Transportation represents about 15 percent of all carbon emissions globally (Center for Climate and Energy Solutions 2017) and about 28 percent of all carbon emissions in the United States (Environmental Protection Agency 2015). It is clear that the way we are currently meeting our mobility needs is unsustainable. We urgently need to reduce our mobility dependence on carbon.

### Chapter Topics

1. [Basics of Climate Change Science](#)
2. [Impact of Transportation Sector on Climate Change Related Emissions](#)
3. [Relation of Emissions with Vehicle Activity](#)
4. [Actions to Mitigate Climate Change Impacts from Transportation](#)
5. [Impacts of Climate Change on Transportation](#)

### Learning Objectives

At the end of the chapter, the reader should be able to do the following:

1. Explain the basic concepts of climate change science.
2. Discuss the anthropogenic drivers of climate change.

3. Identify the transportation decisions and activities contributing to climate change.
4. Select actions to address climate change within the transportation sector considering the economic implications and technological maturity.

## CLIMATE CHANGE

The Earth's climate is continually changing. If we are to understand the current climate and predict the climate of the future, we need to be able to account for the processes that control the climate. One hundred million years ago, much of North America was arid and hot, with giant sand dunes common across the continent's interior. Six hundred and fifty million years ago it appears that the same land mass—along with the rest of the globe—was covered in a layer of snow and ice. What drives these enormous changes through Earth's history? If we understand these fundamental processes we can explain why the climate of today may also change.

### Weather Vs. Climate

**Weather** describes the short term state of the atmosphere. This includes such conditions as wind, air pressure, precipitation, humidity and temperature. **Climate** describes the typical, or average, atmospheric conditions. Weather and climate are different as the short term state is always changing but the long-term average is not. On the 1 of January, 2011, Chicago recorded a high temperature of 6 C; this is a measure of the weather. Measurements of climate include the averages of the daily, monthly, and yearly weather patterns, the seasons, and even a description of how often extraordinary events, such as hurricanes, occur. So if we consider the average Chicago high temperature for the 1 of January (a colder 0.5 C) or the average high temperature for the entire year (a warmer 14.5 C) we are comparing the city's weather with its climate. The climate is the average of the weather.

### The Atmospheric Blanket: The Natural Greenhouse Effect

The Earth's atmosphere is an extremely thin shell compared with the size of our planet. The primary gases in the atmosphere by volume are nitrogen (78.1%), oxygen (20.9%), and argon (0.9%). These figures don't include water vapor, which varies significantly with location and altitude but averages about 0.4% of the atmosphere globally. Other naturally occurring gases include carbon dioxide (designated by chemists as CO<sub>2</sub>), ozone, and methane, which all occur in trace amounts. Although CO<sub>2</sub>, methane, and ozone occur naturally, human activities are increasing their concentrations.

Our planet's fundamental energy source is incoming radiation from the sun, which we will refer to as **incoming solar energy**. Not all of this solar energy is absorbed by the planet. About 29% of it is reflected back into space by the atmosphere, the land surface, and the sea surface. The percentage of solar radiation reflected back into space is called the **albedo**. The primary climate variables responsible for the Earth's 29% albedo are clouds, snow cover, ice sheets, sea ice, glaciers, and oxygen and nitrogen in the atmosphere. In general, whiter substances (clouds, ice, and snow) reflect more solar radiation. The scattering of sunlight by oxygen and nitrogen gives the sky its blue color.

After 29% of the incoming solar radiation is reflected back to space, the Earth absorbs the remaining 71%, which heats the land, ocean surface, and atmosphere. In response, the surface and the atmosphere radiate (i.e., give off) this heat by emitting **infrared radiation**. This infrared radiation

is commonly referred to as **heat energy** because the infrared radiation emitted by any substance depends on its temperature. The higher an object's temperature, the more heat energy it emits.

However, not all of the emitted heat energy can escape to space. The greenhouse gases in the intervening atmosphere absorb (trap) some of this heat energy. As a result, the heat energy leaving the planet is reduced by the intervening atmosphere. It is this trapping of heat energy that otherwise would have escaped to space through the atmosphere that is referred to as the **greenhouse effect**.

### **CO<sub>2</sub> increased by human activities**

While the natural greenhouse effect is vital for maintaining life on Earth, humans have added an enormous amount of carbon dioxide to the thin shell of the atmosphere since the dawn of the Industrial Revolution. As of 2017, we have dumped 2,200,000,000,000 (2.2 *trillion*) tons of carbon dioxide into the atmosphere over the past 240 years. About 45% of that carbon dioxide still remains in the air today. That leaves a blanket of human-generated carbon dioxide in our thin atmospheric shell whose sheer weight is astounding—990 billion tons. That's equivalent to the weight of about 490 billion cars circling the planet all the time.

How do we know the weight of the human-made CO<sub>2</sub>? From direct measurements initiated by Charles David Keeling of the Scripps Institution of Oceanography (UC San Diego). This wiggly curve (Figure 2.1) is called the Keeling Curve and shows the concentration of carbon dioxide in the atmosphere. When Keeling first started making measurements in 1958, the atmospheric carbon dioxide concentration was 313 **parts per million** (abbreviated as 313ppm). That is, out of every million molecules in the atmosphere, 313 were carbon dioxide molecules in 1958.



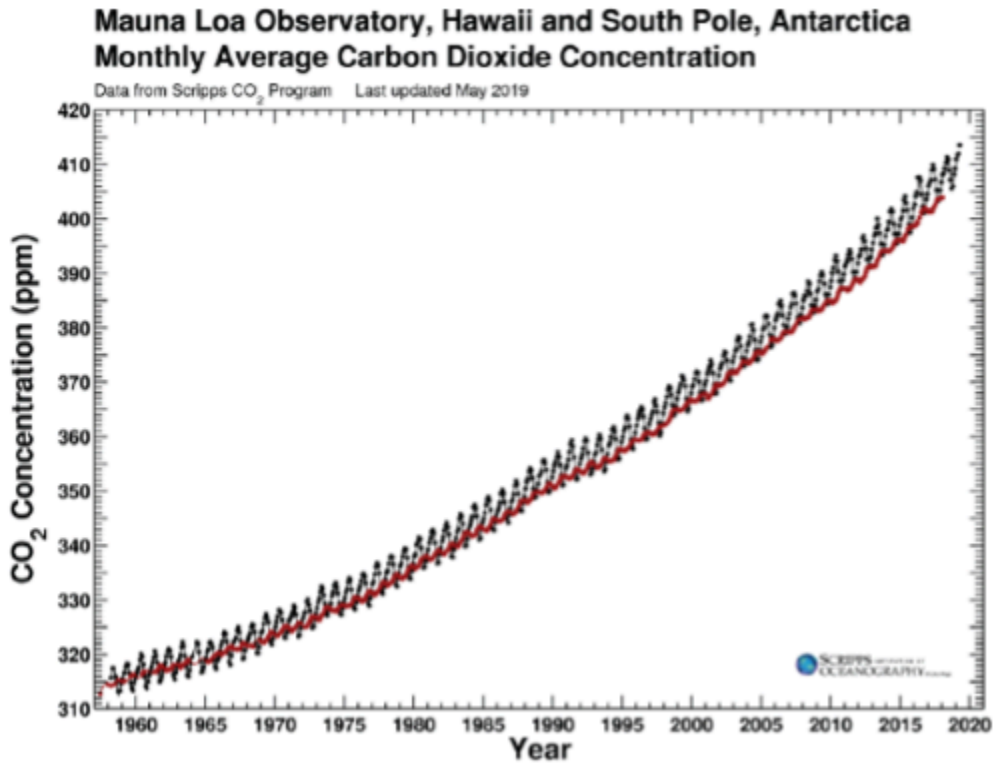

Figure 2.1: The Keeling Curve shows the increase in CO<sub>2</sub> from 1958 to 2017 from ["Bending the Curve: Climate Change Solutions"](#) by Ramanathan et al. and reproduced from the Scripps CO<sub>2</sub> Program from the Scripps Institution of Oceanography is under the following Creative Commons license: [CC BY-NC-SA 4.0](#)

### What are the sources for the observed increase in CO<sub>2</sub>?

Many human activities that address our basic needs, development, and well-being are sources of greenhouse gases. Most of the energy used by society since the Industrial Revolution has come from **fossil fuels**: coal, oil, and natural gas. Burning fossil fuels emits the largest amount of CO<sub>2</sub> by far, contributing an estimated 34 billion tons in 2016. Major anthropogenic sources of carbon dioxide include the following:

1. *Using fossil fuels to produce electricity*: In 2016, 65% of electricity worldwide was generated by burning fossil fuels, including 38% from coal and 23% from natural gas. Coal emits roughly twice as much CO<sub>2</sub> per unit of electricity generated as natural gas, so burning coal to generate electricity is particularly concerning.
2. *Transportation*: There are about 1 billion motor vehicles in use around the world, the vast majority of which use oil-based fuels. Aviation and commercial shipping are also major emitters of carbon dioxide.
3. *Residential and commercial buildings and activities*: In addition to indirect emissions from electricity use, buildings can be a direct source of CO<sub>2</sub> emissions, primarily through heating. In developed countries, natural gas is frequently used for space heating, water heating, and cooking. The least affluent 3 billion, with limited access to fossil fuels, frequently burn wood or animal dung for heating and cooking, which also release CO<sub>2</sub>.



4. *Industrial processes*: A range of industrial processes, in particular cement and steel production, emit significant amounts of CO<sub>2</sub>. Cement production alone is estimated to have been responsible for 2 billion tons of CO<sub>2</sub> emissions in 2016.
5. *Land use*: Changes in land use, in particular burning forests to clear land for farming, grazing, or housing, also emit significant amounts of carbon dioxide. Over the decade 2007–2016, CO<sub>2</sub> emissions from land use averaged about 5 billion tons per year.

## IMPACT OF TRANSPORTATION ON EMISSIONS

Today's transportation systems depend on motor vehicles. As shown in Figure 2.2, by 2017 transportation as a whole had become the largest emitter of greenhouse gases in the United States. In fact, in 2017 the US Environmental Protection Agency (US EPA) reported transportation emissions to be 1,866 million metric tons of CO<sub>2</sub> equivalent (MMT CO<sub>2</sub>e), approximately 29% of total US emissions. If one also considers the refining of fuels and the energy used to build roads, the emissions attributable to transportation are even higher. Where electricity generation has low greenhouse gas (GHG) emissions, transportation's share of the total is much higher. For example, in California in 2017, transportation-related emissions accounted for 41% of California's GHG emissions, or about 48% with refining of transportation fuels.

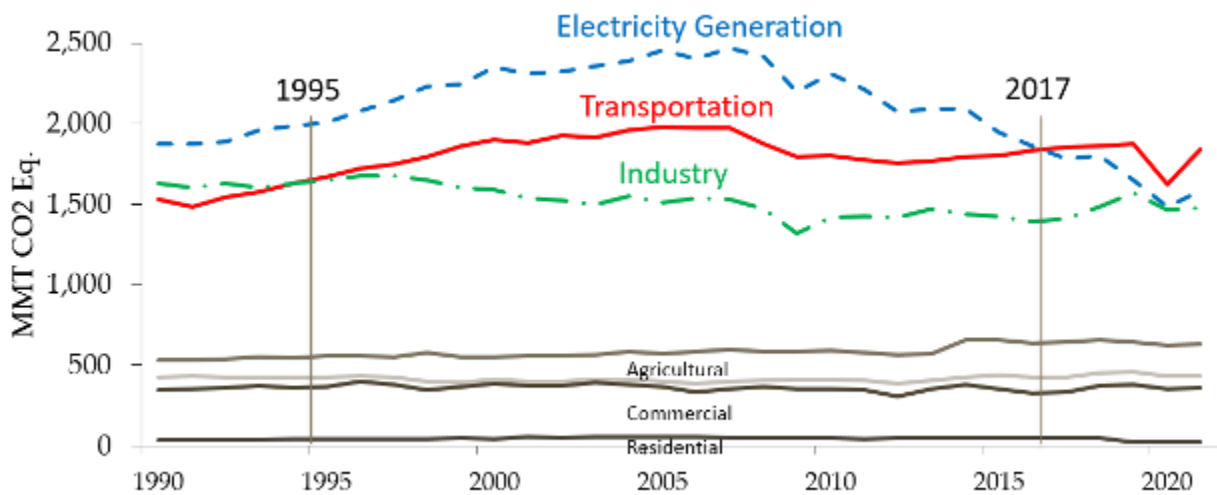

Figure 2.2: Change in Total Greenhouse Gas Emissions from Different Sectors in the United States during 1990- 2023 by Shams Tanvir using data from the EPA is under the following Creative Commons license: [CC BY-NC-SA 4.0](https://creativecommons.org/licenses/by-nc-sa/4.0/)

Transportation is also the largest source of directly emitted air pollutants that cause local air pollution, including carbon monoxide (CO), oxides of nitrogen (NO<sub>x</sub>), and particulate matter (PM). Motor vehicles emit other gases as well, including hydrocarbons (HC) that lead to the formation of ozone (O<sub>3</sub>) and secondary PM. And air-conditioning units in vehicles increase fuel use and emit hydrofluorocarbon (HFC) refrigerant emissions that are short-lived **climate super pollutants**. Vehicle-related pollution causes about 15,000 premature deaths annually in the US and between 184,000 and 242,000 globally.

Fortunately, air quality has dramatically improved in US cities since the 1970s. Figure 2.3 shows that air pollutants from cars and light trucks were reduced by 73% from 1970 to 2016, even though VMT almost doubled.

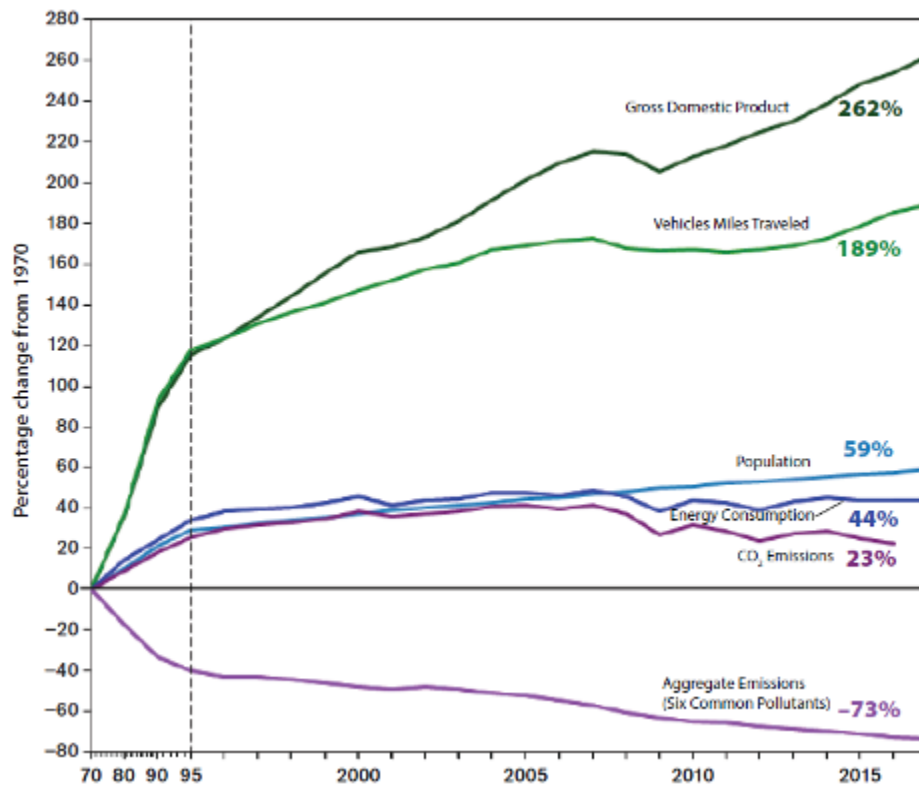

Figure 2.3: [Air pollution emissions yearly trends](#), by Ramanathan et al. (2019) and adapted from US Environmental Protection Agency 2019 is under the following Creative Commons license: [CC BY-NC-SA 4.0](#)

This huge reduction in air pollutants was due to technological advances in vehicle emission control technology and the reformulation of gasoline and diesel fuels. These technology and refining improvements are the result of increasingly stringent performance standards adopted by the US EPA and the California Air Resources Board (CARB). Hydrocarbon and carbon monoxide exhaust emissions from new light-duty vehicles have decreased by over 99% in the US, as shown in Figure 2.4. Massive improvements are also being achieved with trucks, ships, locomotives, and other transportation modes, but they are lagging improvements in cars.

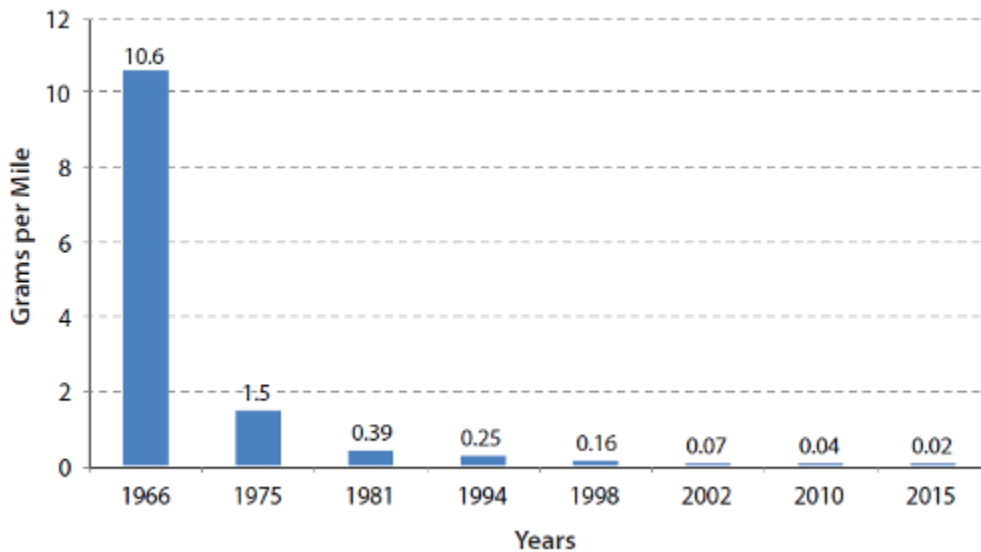

Figure 2.4: “California tailpipe HC performance standards for new light duty vehicle” by Ramanathan et al. (2019) is under the following Creative Commons license: [CC BY-NC-SA 4.0](https://creativecommons.org/licenses/by-nc-sa/4.0/)

## VEHICLE ACTIVITY AND EMISSIONS

In order to understand the breadth of potential transportation-related emissions reductions, it is useful to understand the relationship between vehicle activity and the corresponding emissions. There are several factors that play a role in how much a vehicle emits from the tailpipe. A typical driving trip will consist of idling, accelerating, cruising, and decelerating. The proportion of a trip spent in these different stages will depend on the driver’s behavior (for example, aggressive versus mild driving habits), the roadway type (for example, freeway versus arterial roadway), and the level of traffic congestion.

We can create histograms of emissions for large regional areas. Data collected from passenger vehicles in Southern California are presented in Figure 2.5. As indicated, most trips produce about 330 grams of CO<sub>2</sub> emissions per mile, corresponding to approximately 26 miles per gallon of fuel economy. Other trips, however, produce far less or far more CO<sub>2</sub> emissions per mile, depending on the specific driving pattern. This variation comes from the driver’s behavior, the roadway type, and the level of traffic congestion. Other vehicle types will have quite different emissions depending on their weight, power, and other vehicle factors.

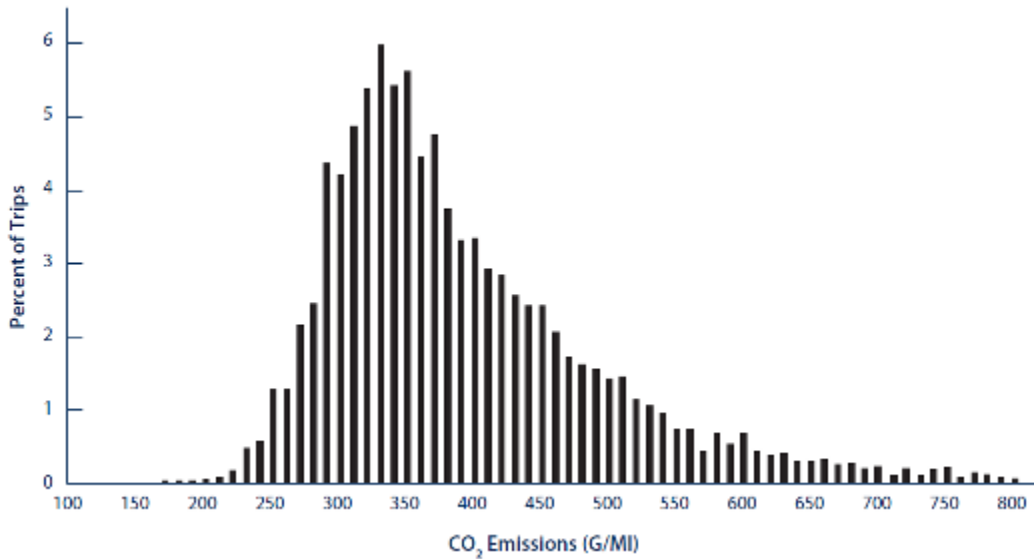

Figure 2.5: “CO<sub>2</sub> emissions, in grams per mile, for a representative database of passenger vehicle trips in Southern California” by Ramanathan et al. (2019) is under the following Creative Commons license: [CC BY-NC-SA 4.0](https://creativecommons.org/licenses/by-nc-sa/4.0/)

Electric vehicles have zero tailpipe emissions, but their energy efficiency (and upstream power plant emissions) is affected by these same factors.

If one plots emissions against speeds, one observes a U-shaped pattern as shown in Figure 2.6. The resulting emissions-speed curve can be generalized for different types of vehicles, different driving behaviors, and different types of trips, as shown in Figure 2.7. This generalized curve can then be used as a tool for evaluating different carbon reduction schemes for transportation management. The upper line in Figure 2.7 shows a representative emissions-speed curve for typical traffic. We can use this curve to examine how different traffic management techniques can affect vehicle emissions such as CO<sub>2</sub>. The lower line represents the approximate lower bound of CO<sub>2</sub> emissions for typical internal combustion vehicles traveling at a constant steady-state speed.

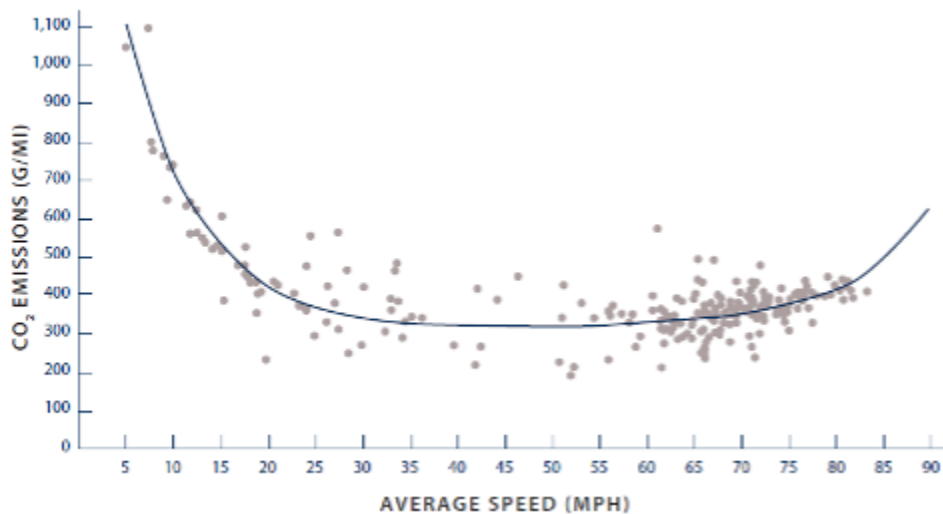

Figure 2.6: “Emission-speed plot of individual trips or trip segments” by Ramanathan et al. (2019) is under the following Creative Commons license: [CC BY-NC-SA 4.0](https://creativecommons.org/licenses/by-nc-sa/4.0/)

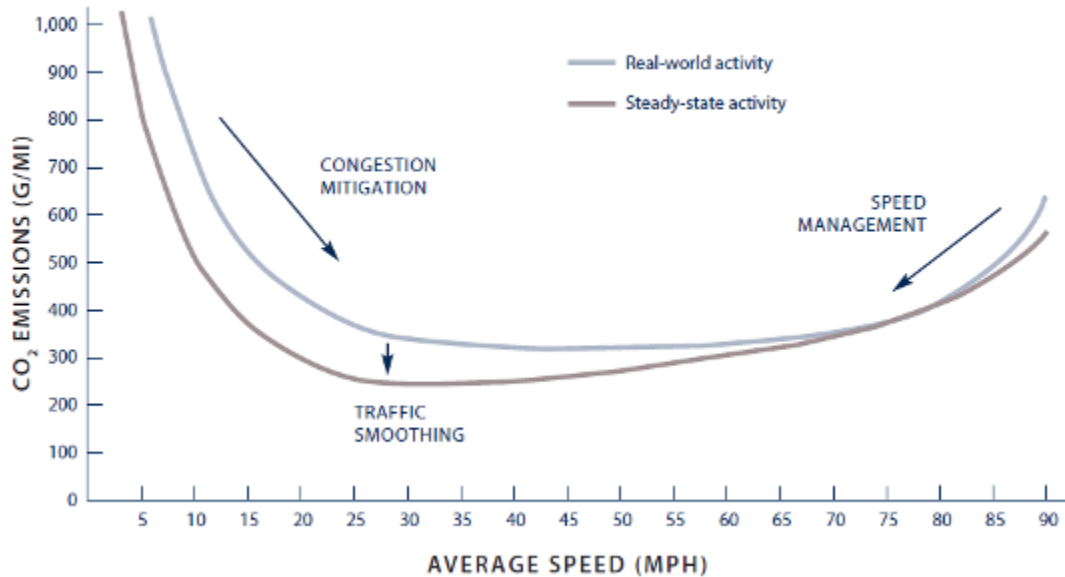

Figure 2.7: “Possible use of traffic operation strategies in reducing on-road CO<sub>2</sub> emissions” by Ramanathan et al. (2019) is under the following Creative Commons license: [CC BY-NC-SA 4.0](https://creativecommons.org/licenses/by-nc-sa/4.0/)

Several important results can be derived from Figure 2.7:

- If congestion reduces the average vehicle speed below 45 mph (for this particular freeway scenario), emissions increase. At these lower speeds, vehicles operate less efficiently and spend more time on the road, resulting in higher emissions. In this scenario, congestion mitigation programs will directly reduce emissions.
- If moderate congestion reduces average speeds from a free-flow speed over 70 mph to a slower speed of 45 to 55 mph, this moderate congestion can reduce emissions (because emissions are higher and energy efficiency is lower at very high speeds). With no congestion, average traffic speeds can increase to over 65 mph, increasing emissions.
- Smoothing stop-and-go traffic will reduce emissions.
- Electric vehicles powered by renewable energy will have near-zero life cycle emissions; if electric vehicles are powered by fossil fuels, emissions from power plants will be lower at lower speeds, for the same reason as for combustion engine vehicles but even more so because regenerative braking captures energy in stop-and-go traffic.

## TRANSPORTATION SECTOR GHG REDUCTION STRATEGIES

Pollutant and GHG emissions can be reduced in many ways. See Figure 2.8 for a simplified framework. GHG emissions may be treated as *primary energy carbon intensity* multiplied by *vehicle and transportation efficiency* multiplied by *total travel demand*.



## CLIMATE CHANGE IMPACTS ON TRANSPORTATION

Climate change will affect transportation primarily through increases in several types of weather and climate extremes, such as very hot days; intense precipitation events; intense hurricanes; drought; and rising sea levels, coupled with storm surges and land subsidence. The impacts will vary by mode of transportation and region, but they will be widespread and costly in both human and economic terms and will require significant changes in the planning, design, construction, operation, and maintenance of transportation systems. The changes made in the transportation system to withstand the climate change impacts increase the system **resilience** against direct and indirect vulnerabilities. In 2008 report of U.S. Transportation Research Board the following statement was made:

*“Potentially, the greatest impact of climate change for North America’s transportation systems will be flooding of coastal roads, railways, transit systems, and runways because of global rising sea levels, coupled with storm surges and exacerbated in some locations by land subsidence... The Atlantic and Gulf Coasts are particularly vulnerable because they have already experienced high levels of erosion, land subsidence, and loss of wetlands...”*

### Key Takeaways

- Human related activities or anthropogenic emissions of carbon dioxide is the prime reason for global climate change.
- Transportation is the highest emitting sector of greenhouse gases in the United States.
- There is a huge variability in carbon emissions among trips made in modern automobile depending on congestion on the route and average traffic speed. Emissions can be controlled by changing the vehicle type or the fuel type used.
- Total travel demand increases the amount greenhouse gas emissions given no change in how the traveling is done.
- Climate change in turn affect how a transportation system is planned, designed, and operated in the future.

### Self-Test



An interactive H5P element has been excluded from this version of the text. You can view it online here: <https://uta.pressbooks.pub/sustainablemobility/?p=109#h5p-2>

## GLOSSARY: KEY TERMS

**Albedo:** The fraction of light that a surface reflects. If it is all reflected, the albedo is equal to 1. If

30% is reflected, the albedo is 0.3. The albedo of Earth's surface (atmosphere, ocean, land surfaces) determines how much incoming solar energy, or light, is immediately reflected back to space.

**Climate:** The weather conditions prevailing in an area in general or over a long period.

**Climate Super Pollutants:** Hydrofluorocarbons (HFCs) are a climate "super-pollutant": greenhouse gases with hundreds to thousands of times the heat-trapping power of carbon dioxide (CO).

**Congestion Pricing:** Fees charged for driving on busy city roads reduce greenhouse gas emissions and improve air quality while also generating funding for the transit systems.

**Eco-Driving:** Adoption of a driving behavior (or a driving style) that aims at saving fuel and reducing harmful emissions of greenhouse gases (GHG).

**Fossil Fuels:** Fossil fuels are formed from the decomposition of buried carbon-based organisms that died millions of years ago. They create carbon-rich deposits that are extracted and burned for energy. They are non-renewable and currently supply around 80% of the world's energy.

**Greenhouse Effect:** a warming of Earth's surface and troposphere (the lowest layer of the atmosphere) caused by the presence of water vapour, carbon dioxide, methane, and certain other gases in the air.

**Heat Energy:** Heat energy is the result of the movement of tiny particles called atoms, molecules or ions in solids, liquids and gases.

**Incident Management:** Planned and coordinated multi-disciplinary process to detect, respond to, and clear traffic incidents and restore traffic flow as safely and quickly as possible.

**Incoming Solar Energy:** Incoming ultraviolet, visible, and a limited portion of infrared energy (together sometimes called "shortwave radiation")

**Infrared Radiation:** Infrared radiation (IR), sometimes referred to simply as infrared, is a region of the electromagnetic radiation spectrum where wavelengths range from about 700 nanometers (nm) to 1 millimeter (mm).

**Parts Per Million (ppm):** This is a way of expressing very dilute concentrations of substances. Just as percent means out of a hundred, so parts per million or ppm means out of a million. Usually describes the concentration of something in air, water or soil. One ppm is equivalent to 1 milligram of something per liter of water (mg/l) or 1 milligram of something per kilogram soil (mg/kg).

**Resilience:** The ability to prepare for changing conditions and withstand, respond to, and recover rapidly from disruptions.

**Traffic Smoothing:** Reduction of acceleration and deceleration (braking) in the traffic stream using traffic management and operations.

**Weather:** A description of the short term state of the atmosphere.

**Work Zone:** A work zone is an area of a trafficway with highway construction, maintenance, or utility-work activities. A work zone is typically marked by signs, channeling devices, barriers, pavement markings, and/or work vehicles.

#### MEDIA ATTRIBUTIONS

- Figure 2.1: ["Bending the Curve: Climate Change Solutions"](#) by Ramanathan et al. (2019) and reproduced from the Scripps CO2 Program from the Scripps Institution of



Oceanography is under the following Creative Commons license: [CC BY-NC-SA 4.0](#)

- Figure 2.2: “Change in Total Greenhouse Gas Emissions from Different Sectors in the United States during 1990- 2023” by Shams Tanvir [using data from the EPA](#) is under the following Creative Commons license: [CC BY-NC-SA 4.0](#)
- Figure 2.3: [“Air pollution emissions yearly trends”](#) by Ramanathan et al. (2019) and adapted from US Environmental Protection Agency 2019 is under the following Creative Commons license: [CC BY-NC-SA 4.0](#)
- Figure 2.4: [“California tailpipe HC performance standards for new light duty vehicle”](#) by Ramanathan et al. (2019) is under the following Creative Commons license: [CC BY-NC-SA 4.0](#)
- Figure 2.5: [“CO<sub>2</sub> emissions, in grams per mile, for a representative database of passenger vehicle trips in Southern California”](#) by Ramanathan et al. (2019) is under the following Creative Commons license: [CC BY-NC-SA 4.0](#)
- Figure 2.6: [“Emission-speed plot of individual trips or trip segments”](#) by Ramanathan et al. (2019) is under the following Creative Commons license: [CC BY-NC-SA 4.0](#)
- Figure 2.7: [“Possible use of traffic operation strategies in reducing on-road CO<sub>2</sub> emissions”](#) by Ramanathan et al. (2019) is under the following Creative Commons license: [CC BY-NC-SA 4.0](#)
- Figure 2.8: [“General approach for calculating GHG emissions from transportation”](#) by Ramanathan et al. (2019) is under the following Creative Commons license: [CC BY-NC-SA 4.0](#)

## REFERENCES

- [Transportation system resilience to extreme weather and climate change](#). FHWA-HOP-15-025. November 2015. Pursuant to Title 17 Section 105 of the United States Code, this file is not subject to copyright protection and is in the public domain. [Copyright information](#).

## ATTRIBUTIONS

- [Bending the Curve: Climate Change Solutions](#) by Ramanathan, V., Aines, R., Auffhammer, M., Barth, M., Cole, J., Forman, is licensed under [CC BY-NC-SA 4.0](#)
- [Climate Change and Transportation, Climate Change and Variability](#) by Yuri Yevdokimov is licensed under [CC BY-NC-SA-3.0](#)

## CHAPTER 3: DESIGN OF BICYCLE FACILITIES

---

### CHAPTER OVERVIEW

This chapter starts with a discussion of the history of bike facilities in the U.S. and abroad. We describe the Highway Capacity Manual (HCM) procedure for evaluating the level of service for bicycle facilities. We then introduce students to bicycle-friendly street design principles. The concept of complete streets is discussed next. Students learn about the practices that improve the safety of bicycle facilities. Intersection design and operations tools to incorporate bicycles are introduced to the students.

#### Chapter Topics

1. [Street Design Elements for Bicycle Facility Design](#)
2. [Level of Service for Bike Facilities](#)
3. [Bicycle-Friendly Street Design Principles](#)

#### Learning Objectives

After completing this chapter, you should be able to:

- Implement bicycle-friendly street design principles.
- Select appropriate street design elements to improve the safety and efficiency of bicycle facilities.
- Design a conventional bike lane.
- Select appropriate design elements to increase accessibility, safety, and efficiency of bicycle operation.
- Calculate the Level of Service (LOS) for bike facilities.

### BICYCLE FACILITIES

Bicycles do not have any internal combustion engines and do not use fossil fuel to operate. In addition, the production and maintenance of bicycles requires a minimum number of raw materials. Therefore, bicycles are considered a true zero-emissions mode. In terms of designing roadway facilities, the term “bicycle facilities” is not limited to the **bike lanes** or the **bike path** used. In addition to the path or space designated for bicycles, bicycle facilities include **intersection** control features, bikeway signing and marking, bicycle storage, and parking facilities.

In this chapter, we will first discuss the types of bicycle facilities. In particular, we will focus on the street design elements that help improve the safety and efficiency of bicycle-based operation. We

will then introduce the concept of network connectivity for planning city or regional level bicycle facilities.

## TYPES OF BICYCLE FACILITIES

Chapter 1000 of the Highway Design Manual (HDM) defines five basic types of bicycle facilities:

1. Shared Roadway (No Bikeway Designation)
2. Class I Bikeway (Bike Path)
3. Class II Bikeway (Bike Lane)
4. Class III Bikeway (Bike Route)
5. Class IV Bikeway (Separated Bikeway)

### Shared Roadway

Most bicycle travel in the United States now occurs on streets and highways without bikeway designation. In some cases, shared roadway will have signs and pavement markings for bicycle operation. Most common type of pavement marking on a shared roadway is “Sharrows” as shown in Figure 3.1.



Figure 3.1: [Sharrow on US1 in West Palm Beach](#) by Michael Rivera is under the following Creative Commons license: [CC BY-SA 4.0](#)

### Bike Paths

Class I bikeways or bike paths are provided to serve corridors not typically served by streets and highways. In most cases, bike paths are added for recreational purposes such as along rivers, ocean fronts, canals, utility right of way, abandoned railway right of way, within school campuses, or within and between parks. Figure 3.2 shows a bike path along California State Highway 35.



Figure 3.2: [Bike route along California State Highway 35](#) by Robert Ashworth is under the following Creative Commons license: [CC BY 2.0](#)

### **Bike Lanes**

Class II bikeway or bike lanes are the most common type of bicycle facility in the United States. Bike lanes are intended to delineate the right of way assigned to bicyclists and motorists and to provide for more predictable movements by each. But a more important reason for constructing bike lanes is to better accommodate bicyclists through corridors where insufficient room exists for side-by-side sharing of existing streets by motorists and bicyclists. Figure 3.3 shows a bike lane on Pleasant Valley Parkway, Providence RI.



Figure 3.3: [Bike lane on Pleasant Valley Parkway, Providence RI](#) by Kenneth C. Zirkel is under the following Creative Commons license: [CC BY-SA 4.0](#)

### Bike Routes

Class III bikeway or bike routes are provided either to (a) provide continuity to other bicycle facilities (usually Class II bikeways); or (b) designate preferred routes through high demand corridors.

As with bike lanes, the designation of bike routes should indicate to bicyclists that there are advantages to using these routes as compared with alternative routes. This means that responsible agencies have taken actions to assure that these routes are suitable as shared routes and will be maintained in a manner consistent with the needs of bicyclists. Normally, bike routes are shared with motor vehicles. Figure 3.4 shows a **wayfinding** sign posted at a junction showing three different bike routes.





Figure 3.4: [Bike route sign with directional information](#) by Richard Drdul is under the following Creative Commons license: [CC BY-SA 2.0](#)

### Separated or Class IV Bikeways

Separated bikeways are also known as cycle tracks. A cycle track is an exclusive bike facility that combines the user experience of a separated path with the on-street infrastructure of a conventional bike lane. A cycle track is physically separated from motor traffic and distinct from the sidewalk. Cycle tracks have different forms but all share common elements—they provide space that is intended to be exclusively or primarily used for bicycles, and are separated from motor vehicle travel lanes, parking lanes, and sidewalks. In situations where on-street parking is allowed cycle tracks are located to the **curb** side of the parking (in contrast to bike lanes). Figure 3.5 shows a two-way cycle track separated by a raised buffer between the motorized vehicle travel lane.



Figure 3.5: [Pandora cycle track 4](#) by Richard Drdul is under the following Creative Commons license: [CC BY-SA 2.0](#)

## BICYCLE LEVEL OF SERVICE

The Highway Capacity Manual Chapter 18 provides guidelines on the method to calculate the bicycle level of service (LOS). The method includes eight main computational steps:

1. Estimation of bicycle running speed
2. Estimation of bicycle delay at intersection
3. Finding bicycle travel speed
4. Estimation of bicycle LOS score for the link
5. Estimation of link LOS
6. Estimation of bicycle LOS score for segment
7. Finding the segment LOS letter grade using the score

Link based LOS determination is a quick approach to find the bicycle infrastructure provided in between the intersection. The segment-based LOS score includes the effect of intersection service and is more appropriate for integrated evaluation of the multimodal level of service.

## STREET DESIGN ELEMENTS

The National Association of City Transportation Officials (NACTO) published [Urban Street Design Guide](#) to publish a toolbox and the tactics the cities could use to make streets safer, more livable, and more economically vibrant. In the guide, NACTO includes some guidance on several main elements of urban street:

1. [Lane Width – concept of “Road Diet”](#)
2. [Sidewalks](#)
3. [Curb Extensions](#)
4. [Gateway](#)
5. [Pinchpoint](#)
6. [Chicane](#)
7. [Bus Bulbs](#)
8. [Vertical Speed Control Elements](#)
  1. [Speed Hump](#)
  2. [Speed Table](#)
  3. [Speed Cushion](#)
9. [Transit Streets](#)
  1. [Dedicated curbside bus lane](#)
  2. [Dedicated median bus lanes](#)
  3. [Contraflow bus lanes](#)
  4. [Bus stops](#)
10. [Storm water management](#)
  1. [Bioswales](#)
  2. [Flow through planters](#)
  3. [Pervious strips](#)
  4. [Pervious pavement](#)

## DESIGN OF CONVENTIONAL BIKE LANE

The NACTO [Urban Bikeway Design Guide](#) includes specific design guidelines for Class II bikeway facility. Among the different types of bike lanes, conventional bike lanes are the most common type. Below are some required guidelines for designing conventional bike lanes:

1. The desirable bike lane width adjacent to a curbface is 6 feet. The desirable rideable surface adjacent to a street edge or longitudinal joint is 4 feet, with a minimum width of 3 feet. In cities where illegal parking in bike lanes is an concern, 5 foot wide bike lanes may be preferred.



2. When placed adjacent to a parking lane, the desirable reach from the curb face to the edge of the bike lane (including the parking lane, bike lane, and optional buffer between them) is 14.5 feet; the absolute minimum reach is 12 feet. A bike lane next to a parking lane shall be at least 5 feet wide, unless there is a marked buffer between them. Wherever possible, minimize parking lane width in favor of increased bike lane width.
3. The desirable bike lane width adjacent to a guardrail or other physical barrier is 2 feet wider than otherwise in order to provide a minimum shy distance from the barrier.
4. Bicycle lane word and/or symbol and arrow markings (MUTCD Figure 9C-3) shall be used to define the bike lane and designate that portion of the street for preferential use by bicyclists.
5. Bike lane word, symbol, and/or arrow markings (MUTCD Figure 9C-3) shall be placed outside of the motor vehicle tread path at intersections, driveways, and merging areas in order to minimize wear from the motor vehicle path.
6. A solid white lane line marking shall be used to separate motor vehicle travel lanes from the A through bike lane shall not be positioned to the right of a right turn only lane or to the left of a left turn only lane (MUTCD 9C.04). A bike lane may be positioned to the right of a right turn only lane if split-phase signal timing is used. For additional information, see bicycle signal heads. For additional strategies for managing bikeways and right turn lanes, see through bike lanes in this guide. bike lane. Most jurisdictions use a 6 to 8 inch line.

## PROTECTED INTERSECTION

The concept of protected intersection is discussed in the NACTO Guide [Don't Give Up at the Intersection](#).

At protected intersections, the bikeway is set back from the parallel motor vehicle traffic. Unlike at conventional bike intersections, people biking are not forced to merge into mixed traffic. Instead, they are given a dedicated path through the intersection, and have the right of way over turning motor vehicles.

The setback between the motor vehicle lane and the bikeway makes people on bikes more easily visible to turning drivers than in a conventional intersection.

Corner islands anchor the design, extending the protected bike lane's separation as far into the intersection as possible and tightening the corner's turn radius. They create a bike queue area after the crosswalk, the natural place for people on bikes to wait.

The setback creates a waiting zone for turning cars, where drivers can yield to bikes after starting to turn but before crossing the path of oncoming bicycles. If it is large enough, this area lets drivers wait while through-traffic passes them, relieving pressure to turn too quickly.

Protected intersections also provide shorter, safer crossings for people walking. With low-speed vehicle turns and room for accessible pedestrian islands, people on foot and using personal mobility devices get many of the benefits of curb extensions.

Protected intersections create shorter, simpler crossings, more predictable movements, and better visibility between people on bikes and people driving. As a result, the intersection is more comfortable and safer for people using the bikeway and the crosswalk.

Figure 3.6 shows the important elements of a protected intersection.

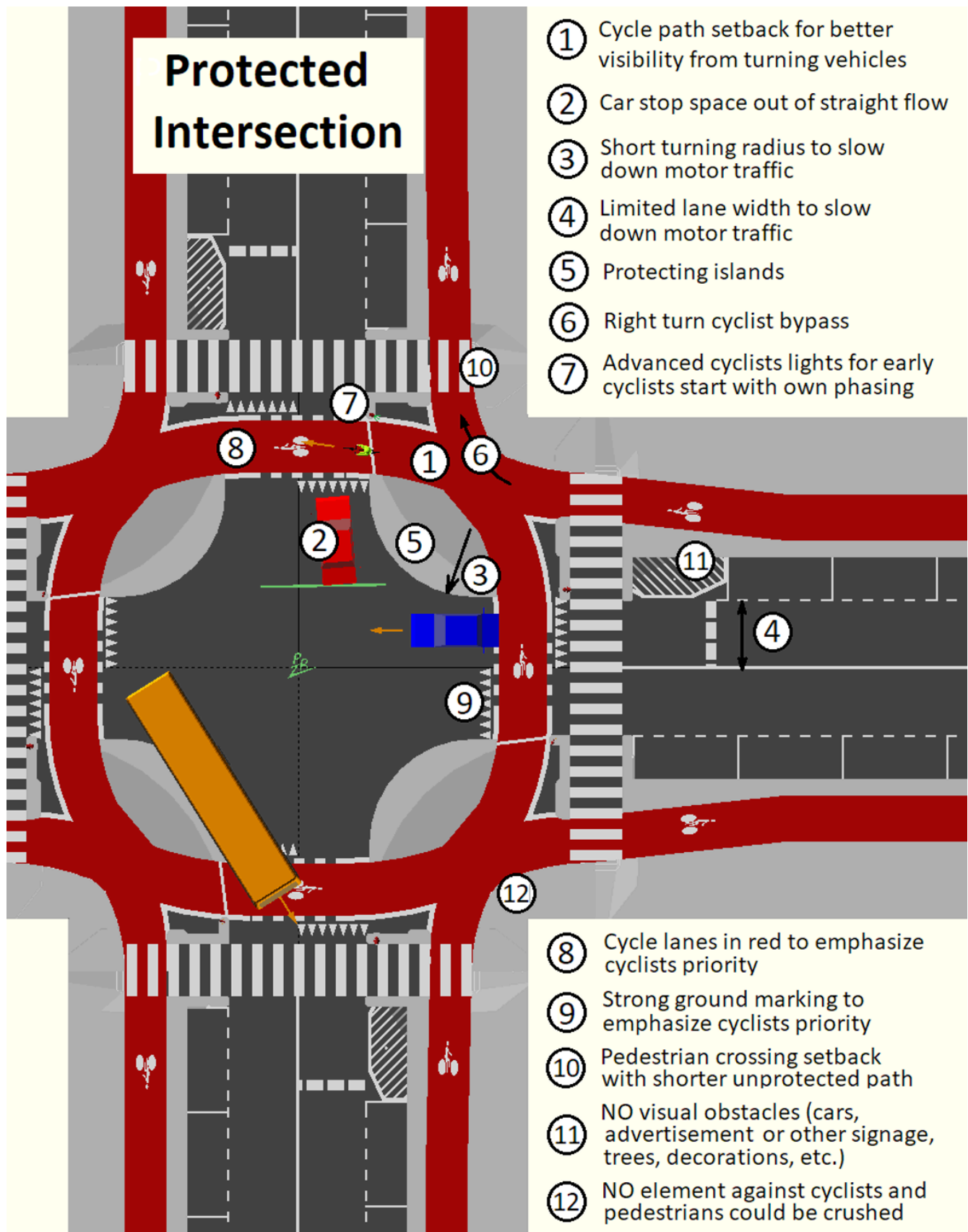

Figure 3.6: [Protected intersection features](#) by Pierre Rouzeau via Wikimedia Commons is under the following Creative Commons license: [CC BY-SA 4.0](#)

## Key Takeaways

- There are five types of bicycle facilities as defined by Highway Design Manual (HDM) of California Department of Transportation.
- Highway Capacity Manual provides a methodology to quantitatively measure Bicycle Level of Service (LOS).
- The NACTO Urban Street Design Guide includes design recommendations and specifications for key urban street design elements.
- Conventional bike lane design specifications are included in the NACTO Urban Bikeway Design Guide.

## Self-Test



An interactive H5P element has been excluded from this version of the text. You can view it online here: <https://uta.pressbooks.pub/sustainablemobility/?p=161#h5p-3>

## GLOSSARY: KEY TERMS

**Curb:** A stone or concrete edging to a street or path

**Bike Lane:** a portion of the roadway that has been designated by striping, signage, and pavement markings for the preferential or exclusive use of bicyclists.

**Bike Path:** A bike path or a cycle path is a bikeway separated from motorized traffic and dedicated to cycling or shared with pedestrians or other non-motorized users.

**Intersection:** A point at which two or more roadway approaches intersect.

**Wayfinding:** A bicycle wayfinding system consists of comprehensive signing and/or pavement markings to guide bicyclists to their destinations along preferred bicycle routes.

## MEDIA ATTRIBUTIONS

- Figure 3.1: [Sharrow on US1 in West Palm Beach](#) by Michael Rivera is under the following Creative Commons license: [CC BY-SA 4.0](#)

- Figure 3.2: [Bike route along California State Highway 35](#) by Robert Ashworth is under the following Creative Commons license: [CC BY 2.0](#)
- Figure 3.3: [Bike lane on Pleasant Valley Parkway, Providence RI](#) by Kenneth C. Zirkel is under the following Creative Commons license: [CC BY-SA 4.0](#)
- Figure 3.4: [Bike route sign with directional information](#) by Richard Drdul is under the following Creative Commons license: [CC BY-SA 2.0](#)
- Figure 3.5: [Pandora cycle track 4](#) by Richard Drdul is under the following Creative Commons license: [CC BY-SA 2.0](#)
- Figure 3.6: [Protected intersection features](#) by Pierre Rouzeau via Wikimedia Commons is under the following Creative Commons license: [CC BY-SA 4.0](#)

## REFERENCES

- AASHTO Task Force on Geometric Design (1999). *AASHTO Guide for the Development of Bicycle Facilities*. American Association of State Highway and Transportation Officials, Washington, DC.
- California Department of Transportation (Caltrans). (2020). *Chapter 1000:– Bicycle Transportation Design, Highway Design Manual*. Sacramento, CA.
- National Association of City Transportation Officials (NACTO).
- National Academies of Sciences, Engineering, and Medicine. (2022). *Highway capacity manual 7th edition: A guide for multimodal mobility analysis*.

## CHAPTER 4: DESIGN OF PEDESTRIAN FACILITIES

---

### CHAPTER OVERVIEW

In this chapter, we introduce the challenges of using pedestrian facilities first. Next, we discuss the processes to analyze a given sidewalk for the measures of safety, efficiency, and comfort. Students are trained to find inconsistencies in the existing pedestrian facility design and apply corrective measures to improve safety, efficiency, and comfort of pedestrian operations.

#### Chapter Topics

1. [Challenges of using pedestrian facilities](#)
2. [Process to analyzing sidewalks](#)
3. [Pedestrian facility improvement approaches](#)

#### Learning Objectives

At the end of the chapter, the reader should be able to do the following:

1. Conceptualize the challenges of using pedestrian facilities.
2. Describe the historical contexts of decline in sidewalk life.
3. Calculate pedestrian level of service for a given sidewalk .
4. Apply intersection management for pedestrians.

### CHALLENGES OF USING PEDESTRIAN FACILITIES

Pedestrian facilities refer to **sidewalks**, **crosswalks**, grade separated pedestrian crossings, **shared use paths**. In 2017, on a typical day in the United States, approximately 38.9 million trips were undertaken primarily by walking, representing 10.5% of trips made by all modes, making walking the second-most prevalent transportation mode after driving or riding in a private motor vehicle. Furthermore, most trips involving private vehicles or public transit involve an element of walking, whether walking to and from parking places or walking to or from transit stops and stations.

As a transportation mode, walking is healthy for individuals and beneficial for the environment. Twenty five years ago, the US Surgeon General highlighted the importance of walking for exercise as a means of combating obesity, diabetes, and other diseases. Since then, a wealth of studies published in public health and medical journals have extolled the virtues of walking. Moved by concerns about climate change, energy, and congestion, transportation planners now view walking as an inexpensive and enjoyable activity that could replace short auto trips, thus reducing congestion

and fossil fuel consumption. Yet despite the general consensus that walking brings many benefits, policymakers still aren't sure how to increase the amount of walking people actually do. One of the most obvious approaches is to improve pedestrian infrastructure. Walking is harder in places without good sidewalks, and the sidewalks in many cities are in terrible disrepair. Many other places have no sidewalks at all. But good sidewalks, while important, will not by themselves lead to more walking. Changes in the built environment are a necessary but not sufficient condition for a pedestrian-friendly city.

Urban areas where people enjoy walking have more than just a functional pedestrian infrastructure. Sidewalks are not like major streets, many of which are designed solely to move cars. Sidewalk users are more exposed to their environments than drivers, both because pedestrians are not encased in vehicles and because they move through their environments more slowly than do people in cars. For this reason sidewalk users also require more from their environments. A successful sidewalk is more than just a route for getting from Point A to Point B; it is also a place to abide, to meet others, and to participate in neighborhood life. Urban sidewalks, as Jane Jacobs once argued, are a city's "most vital organs," where people experience city life, enjoy neighborhood rhythms, and watch what goes on. Pedestrianism—moving on foot, in a wheelchair, or with other mobility devices—is only one dimension of the sidewalk experience. Sidewalks thrive as multi-use environments, not as pure pedestrian thoroughfares.

Many sidewalks in US cities lack the people and variety of activities that characterize sidewalks in Europe, Asia, or Latin America, but this was not always the case. Nineteenth and early twentieth century US sidewalks were vibrant spaces. Policy-makers began to perceive sidewalks exclusively as transportation infrastructure; however, they used the goal of unrestricted movement as a justification to restrict other activities, including public speaking, vending, socializing and loitering. Removing these activities sapped the sidewalk of life and vitality. The singular view of streets and sidewalks as transportation routes, later combined with policies that overwhelmingly favored motorists over pedestrians, inadvertently made walking a less critical dimension of urban living.

Planners who want to reinvigorate pedestrian spaces today face a difficult challenge. Building infrastructure alone will not work, because people are more likely to walk in areas that host a diversity of uses. Some uses, however, potentially conflict—a panhandler and a shopper can occupy the same space, but the panhandler might make the shopper uncomfortable. Planners have tried to finesse this problem by encouraging certain kinds of uses, and by encouraging pedestrianism only in certain places, creating upscale pedestrian hubs and leisure destinations. These efforts at control often raise hard questions about democracy and legality, and in any event are rarely effective ways to encourage more walking. We propose that more people will walk or roll in wheelchairs when sidewalks are spaces that accommodate the full range of activities that make cities interesting.

We first discuss how a singular focus on sidewalks as spaces of movement contributed to the decline of sidewalk life, and to walking as well.

### **The Rise of Single Purpose Sidewalk**

In the 19th century, curbs and sidewalks became common along heavily traveled city streets. These early sidewalks were often constructed by the abutting businesses and property owners. By the century's end, sidewalks had become important elements of the urban infrastructure, and thousands of miles of sidewalks had been paved in American cities. Because sidewalks were often paved before the rest of the street, they were the easiest place to walk, and the easiest place to carry out various

economic and social activities. In commercial areas, sidewalks extended the realm of adjacent shops; shopkeepers displayed their merchandise on sidewalks and stored deliveries and overstock on them as well. Street peddlers made a living outdoors while street speakers and newsboys conveyed information to passersby. Sidewalks were also a realm for social encounters where friends, acquaintances, and strangers mixed. The sidewalks were thus both a route and a destination; a way to move through the city, but also a place of commerce, social interaction, and civic engagement.

As sidewalks proliferated, municipalities began to standardize them. Cities specified sidewalk dimensions, construction standards, and materials to ensure consistency and durability. At the same time, cities began to standardize streets and to require durable paving for the roadbed and travel lanes. With this standardization, the nature of the urban sidewalk began to change, and its range of uses began to contract. Municipal engineers began to focus narrowly on efficient transportation and the importance of clean streets. Cities prohibited abutting property owners from using the sidewalks as extensions of their businesses, and the courts—when businesses challenged cities—upheld the cities’ authority to do so. In the process, walking for transportation became sidewalks’ primary purpose and the pedestrian the primary user. The pedestrian’s unobstructed mobility justified subsequent municipal restrictions on other sidewalk activities. Consequently, the pedestrian became the sole “public” for whom the sidewalks were provided.

Cities applied a similar logic to streets. The advent of local planning further changed the street from a locally-oriented public space to a transportation corridor. Municipalities developed public paving projects whose primary goal was traffic movement. In the late 19th century pedestrians grumbled about the hindrances that blocked sidewalks; by the turn of the century pedestrians found they had become the hindrance, regarded by local planners as “obstructions” to the automobile. The sidewalk shifted from being the most convenient space for walking to the only legitimate space for walking. As pedestrians became “encroachers” into the roadbed, they were viewed as a source of accidents and congestion. City councils restricted pedestrian crossings to intersections, required pedestrians to obey traffic signals and instituted fines for jaywalking.

As automobiles proliferated in the early twentieth century, newspaper editorials blamed pedestrians for accidents because they defied the rules of the road and walked into moving vehicles. “*The dumb pedestrian really is pretty dumb,*” a columnist from *Westways* magazine wrote in 1937: “*As a pedestrian the average man is not very bright.... As an incorrigible individualist, the pedestrian is intellectually inferior to the motorist in his traffic conduct.*” As early as 1912, urban infrastructure trade magazines such as *American City* advised widening streets at the expense of sidewalks. Pedestrians were banned from streets to make room for cars, and a myriad of activities were banned from sidewalks to make room for pedestrians. But the sidewalks had never been about walking alone, and so in the process of creating an efficient transportation system, public officials, municipal engineers and the courts also enervated sidewalk life.

### **Too Much Control**

When cities redefined sidewalks as transportation corridors, they also gave themselves another reason to control sidewalk life. Anything that impeded pedestrian circulation could be restricted or prohibited. Cities throughout the nation issued ordinances to regulate sidewalk activities including loitering, panhandling, street vending, public speaking, and expressions of political dissent.

By the middle of the 20th century, urban sidewalks were used for fewer activities, and more people spent time in controlled environments like malls. And despite the recent popular and scholarly

attention to walking, in a 2003 survey of the ten largest California cities, we found that public officials continued to deploy four strategies that devalued sidewalks as multi-use spaces. First, they de-emphasized sidewalks by developing sunken and raised plazas and elevated walkways. Second, they gentrified select sidewalk segments to make them attractive destinations with shopping, restaurants and bars while making few if any improvements to the remaining sidewalk network. Third, they privatized particular sidewalks through the designation of business improvement districts and by fencing and enclosing outdoor seating. And lastly, cities sought to contain undesirable sidewalk activities they could not eliminate. We will discuss each of these strategies in turn.

*De-emphasis.* In downtown and commercial areas, cities let (and sometimes encourage) developers of privately provided plazas and open spaces to use enclosing walls, blank facades, and entrances through parking structures, all of which separate their properties from public sidewalks. Cities nationwide have built underground and overhead spaces—sunken plazas and skywalks—to provide pedestrian circulation that avoids the street. In cities such as Minneapolis-St. Paul, Detroit, Boston and Cincinnati, skywalks link high-rise towers to a network of tunnels leading people from underground garages to office cubicles, allowing workers and visitors to move through the downtown without setting foot on public sidewalks. While initially meant to address harsh winters, skywalks also appear in cities with warm climates such as Dallas, Los Angeles, Miami, San Francisco, and Santa Cruz.

*Gentrification.* In the last few decades, many municipalities have invested in historic districts and main streets to draw middle class residents and shoppers back to the city. Their efforts include upgrading the streetscape through a mix of public art, street furniture, and decorative lighting, renovating buildings, and converting old warehouses into trendy shops and restaurants. Cities have also enacted ordinances designating some “pedestrian-oriented” districts, and encouraging specific retail uses (cafes, bakeries, restaurants, flower shops, boutiques, bookstores, galleries, art shops) in these districts. Architectural and landscape design guidelines promote specific themes to retain or enhance an area’s historic character. The objective is to increase land value and overall economic viability. In the process, small, independent businesses such as nail salons, tattoo parlors and small food stores are often replaced by chain stores and upscale retailers. The new consumer orientation reflected in the higher prices and more upscale merchandise creates a subtle but effective screening mechanism and makes the sidewalks comfortable for only higher income populations.

*Privatization.* Many states have enabled Business Improvement Districts (BIDs) in which business owners tax themselves to augment public services or provide improvements for a designated district. Services offered by BIDs typically include sidewalk beautification, cleaning and maintenance, and private security officers. BID security officers ensure that sidewalk activity is not disruptive to businesses. Some urban residents become nuisances if they do not fit the BID’s desired image for the neighborhood. Fencing a part of the sidewalk for outdoor seating is another form of privatization. Fences are boundaries that separate the privatized realm from public space. This might be required by ordinance, as is the case of California where state law stipulates that alcohol can be served only in enclosed and demarcated areas. While cafes can blend seamlessly into the city sidewalks, as they do in Paris, too often in the US hard boundaries privatize public space and thus preclude different public uses.

*Containment.* Who has access to which sidewalks is controversial. To contain undesirable uses, cities directly or indirectly sanction activities in one area to keep them out of another. Local governments restrict prostitution to red light districts and homelessness to skid rows. Some cities have extended



this logic to street vending, allowing it in some areas while prohibiting it in others. At times, cities have attempted to confine protest events and political speech to officially-approved protest zones.

Some of the strategies above have helped empty public sidewalks of people and activities. Others have encouraged the use of sidewalks, but only by a subset of the population, and in doing so they make the sidewalk less public.

## PEDESTRIAN LEVEL OF SERVICE (PLOS)

The Highway Capacity Manual Multimodal Level of Service (MMLOS) outlines a detailed process to analyze a sidewalk. Usually, this detailed approach is used in facility planning or interchange area management plan (IAMP), project development, and development review. However, the Qualitative Multimodal Assessment (QMA) methodology is most suited when comparing different alternatives side-by-side to each other. This methodology uses the roadway characteristics and applies a context-based subjective “Excellent/Good/Fair/Poor” rating.

For example, a six foot sidewalk is standard in a residential area and would be rated Good (or Excellent if it had a buffer). Ratings can be “averaged” to obtain one for every mode, or they can be shown for every element if more detail is desired e.g. in a technical appendix. This method is most appropriate when one or more of the following conditions apply:

1. The subject roadway does not easily divide into segments with uniform characteristics between intersections.
2. The subject roadway has rural/suburban characteristics with infrequent or no signal control, where the MMLOS methodology is not applicable.
3. Insufficient data are available to complete a MMLOS analysis
4. Future alternatives may not have enough detail to properly quantify roadway characteristics required by other methodologies.

For calculating the pedestrian level of service using QMA, the following factors are considered at the segment level:

**Outside travel lane width:** Wider travel lanes are rated better than narrower travel lanes because of the larger buffer space between vehicles and pedestrians.

**Bicycle lane/shoulder width:** The addition of bicycle lanes or shoulders creates greater separation between vehicles and pedestrian traffic and acts as a buffer. Wider facilities are rated better than narrow or non-existent facilities.

**Presence of buffers (landscaped or other):** Buffer presence that separates pedestrians from traffic results in an improved rating. Wider buffers are rated better than narrower or non-existent ones.

**Sidewalk/path presence:** The presence of sidewalks or paths will rate higher versus shoulders or no facilities at all. Wider sidewalks/paths rate better than narrower or non-existent ones.

**Lighting:** The presence of lighting, whether roadway or pedestrian-scale, is rated better than roadways without lighting.

**Travel lanes and speed of motorized traffic:** Less travel lanes and lower vehicle speeds will rate higher than more lanes and higher speeds.

At intersections, the following factors are considered:

**Traffic control:** Intersections with a traffic signal or all-way stop control, or with marked

crosswalks are rated better than locations with only two-way stop control or locations without marked crosswalks.

**Crossing width:** Fewer turn or through travel lanes to be crossed is rated better than more turn/through lanes because the exposure to traffic and potential conflicts are less.

**Median islands:** The presence of a **median** island is rated better than no islands as two-stage crossings significantly improve the associated safety and ease when using a crossing.

## PEDESTRIAN FACILITY IMPROVEMENT STRATEGIES

Contributing factors to pedestrian crashes often include a high density of driveways along a roadway segment, high motor vehicle speeds and volumes, and poor pedestrian facility conditions (e.g., cracked or raised sidewalks, significant potholes in pedestrian crossings).

Other potential contributing factors include the state of crash-involved drivers and pedestrians, such as levels of alcohol or drug impairment, distraction, and demographic factors including age and gender.

In identifying factors that may have contributed to a vehicle–pedestrian crash, the analyst can examine police-provided crash diagrams or other available contextual information to consider the following:

- Vehicle speed;
- Driver and pedestrian compliance with regulations and traffic devices;
- Pedestrian crossing behaviors;
- Human factors related to sight distance and the density of distractions in the environment (e.g., signs, signals, noise);
- Built environment or land use area type;
- Intersection presence and types of traffic control devices;
- Pedestrian crossing distance;
- Time of day/day of week/seasonal factors;
- Alcohol impairment on the part of pedestrians or drivers;
- Distraction on the part of pedestrians or drivers;
- Demographics;
- Special populations, such as school-aged children, older adults, and persons with disabilities;
- Presence of transit stops; and
- Density of driveways along a segment or corridor.

The following pedestrian safety countermeasures have the potential to improve pedestrian safety. The effectiveness of these countermeasures lies in their ability to reduce vehicular speeds by adding friction to the driving environment, by enhancing the visibility of pedestrians, or both.

### **High-visibility crosswalk:**

Vertically arranged street markings designed to improve the visibility of the crosswalk as compared with traverse parallel lines.

**Raised crosswalk/speed table:**

An elevated section of pavement with a marked crosswalk to encourage drivers to slow down.

**Median crossing (refuge) island:**

A protected space placed in the center of the street to facilitate pedestrian crossings by allowing pedestrians to cross only one direction of traffic at a time.

**In-roadway “Yield to Pedestrian” sign (R1-6) installed as a gateway treatment:**

R1-6 signs placed at a crosswalk along the edge of the road and on all lane lines, thus requiring drivers to slow down to drive between two signs.

**Pedestrian hybrid beacon (HAWK):**

A traffic control device used to stop motor vehicle traffic to allow pedestrians to cross safely.

**Leading pedestrian interval:**

Provides pedestrians with a 3- to 7-second head start when entering an intersection relative to the green signal for parallel vehicular traffic.

**Rectangular rapid-flashing beacon:**

User actuated amber LED blocks that supplement warning signs at unsignalized intersections or midblock crosswalks. They can be manually activated by pedestrians using a push button or passively activated by a pedestrian detection system.

**Curb extension:**

An extension of the pedestrian space at intersections designed to increase the visibility of crossing pedestrians and reduce their crossing distance

**Pedestrian lighting:**

Humanscale lights that illuminate spaces where pedestrians walk along and across roadways

Key Takeaways

- City spaces that accommodate wide range of activities and have less control creates walkable conditions.
- The Qualitative Multimodal Assessment (QMA) technique provides a quick approach to analyze an existing sidewalk and is a qualitative approach to the Pedestrian Level of Service (PLOS) determination.
- Techniques that reduce vehicle speed and improve the visibility of pedestrian and vehicles.

Self-Test



■ An interactive H5P element has been excluded from this version of the text. You can view it online here:  
<https://uta.pressbooks.pub/sustainablemobility/?p=181#h5p-4>

## GLOSSARY: KEY TERMS

**Crosswalk:** a marked part of a road where pedestrians have right of way to cross.

**Median:** the strip of land between the lanes of opposing traffic on a divided roadway.

**Shared use paths:** A shared-use path, mixed-use path or multi-use pathway is a path which is “designed to accommodate the movement of pedestrians and cyclists”. Examples of shared-use paths include sidewalks designated as shared-use, bridleways and rail trails.

**Sidewalk:** A paved path for pedestrians set along the side of a roadway.

## REFERENCES

- Transportation Officials. (2004). [Guide for the planning, design, and operation of pedestrian facilities](#). AASHTO.

## ATTRIBUTIONS

- [Vibrant Sidewalks in the United States: Re-Integrating Walking and a Quintessential Social Realm](#) by Anastasia Loukaitou-Sideris and Renia Ehrenfeucht is licensed under [CC BY-NC 4.0](#)

## CHAPTER 5: ENERGY CONSUMPTION AND EMISSIONS FROM TRANSPORTATION

---

### CHAPTER OVERVIEW

In this chapter, we move the focus from non-motorized transportation to automobility. The basics of energy consumption pathways for automobility are introduced. Students learn about the history of energy mix and emissions control processes at both stationary and mobile emissions sources. We then discuss the methods for calculating energy requirements for different transportation activities. This chapter introduces the methods to calculate greenhouse gas emissions and other transportation related pollutant emissions. The concept of near-road exposure to public health outcomes is explained next.

#### Chapter Topics

1. [Energy Pathways for Automobility](#)
2. [Life Cycle Analysis](#)
3. [Fuel Use and Emissions for Road Traffic](#)
4. [Aggregation and Estimation of Systemwide Energy Consumption and Emissions](#)

#### Learning Objectives

At the end of the chapter, the reader should be able to do the following:

- Recognize the historical context of fossil fuel dependency in the transportation sector and list the various energy pathways to meet the same transportation needs.
- Estimate energy consumption for multimodal transportation activities.
- Aggregate energy consumption and emissions of different transportation components to estimate the systemwide energy consumption and emissions.
- Calculate total emissions for different policy alternatives related to automobility.
- Calculate the energy and environmental footprints of the existing scenario and the proposed improvements.

### ENERGY PATHWAYS FOR AUTOMOBILITY

Pollutant and greenhouse gas (GHG) emissions can be reduced in many ways. See Figure 5.1 for a simplified framework. GHG emissions may be treated as primary energy **carbon intensity** multiplied by vehicle and transportation efficiency multiplied by total travel demand.

Primary energy carbon intensity can be reduced by using lower-carbon fuels or low-carbon electrification, which is described later in this section. The energy needed to drive a specific distance can be reduced by improving both (1) vehicle efficiency and (2) transportation system efficiency, again assuming no induced demand. This analytical construct—separating the determinants of emissions into carbon intensity, efficiency, and demand—can be used as a policy framework. A large carbon tax would address all three strategies, though it must be very large to be effective. In practice, an environmentally sustainable transportation solution will depend on a mix of policies and strategies.

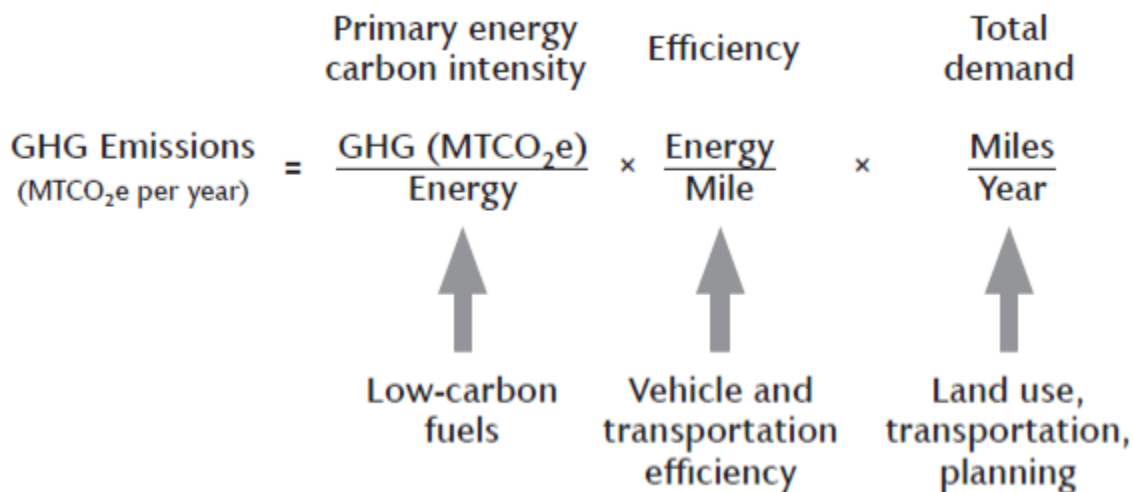

Figure 5.1: [General approach for calculating GHG emissions from transportation](#) by Ramanathan et al. (2019) under [CC BY-NC-SA 4.0](#)

As you can see from Figure 5.1, different vehicle technologies and fuel technologies will directly impact the total amount of GHG emissions from the transportation sector. In the following subsections, we will discuss various vehicle and fuel technologies available in the market.

### Vehicle (Powertrain) Technology

There has been considerable effort over the years to make vehicles more **energy efficient**, thereby reducing pollutant and GHG emissions. Many of these vehicle-based technologies are described in Chapter 6. In recent years, vehicles have benefited from lighter materials and more-efficient combustion engines and powertrains. In just the past few years, the greater use of electric powertrains, including gasoline-electric, plug-in hybrid, battery electric, and fuel cell electric technologies, has provided the promise of even much greater efficiency improvements. Overall vehicle efficiency improvements are illustrated in Figure 5.2 for different areas of the world.

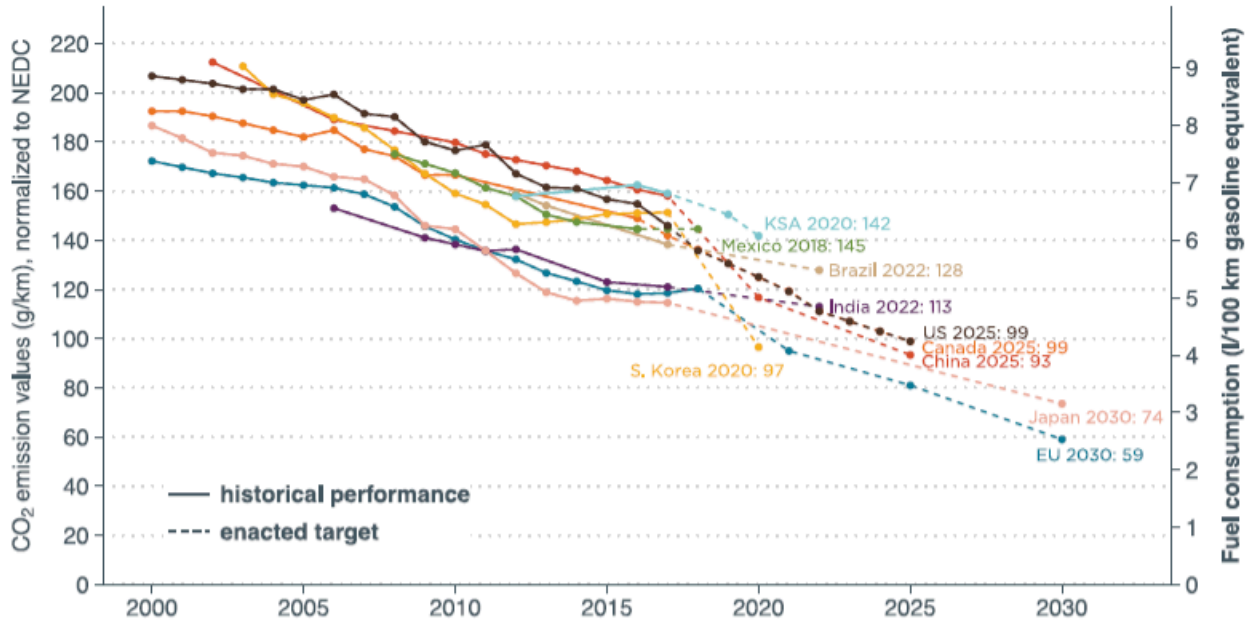

Figure 5.2: [Average passenger car GHG emissions normalized by distance traveled for different regions](#) by Ramanathan et al. (2019) under [CC BY-NC-SA 4.0](#)

The improvements are due to a combination of aggressive policies and large technology investments by automobile manufacturers. The increasing use of electric powertrains provides the promise for continued improvements in energy efficiency. The continuing drop in battery costs assures that this trend will continue into the foreseeable future. Figure 5.3 illustrates the number of electric vehicles (EVs) that are being introduced in different parts of the world.

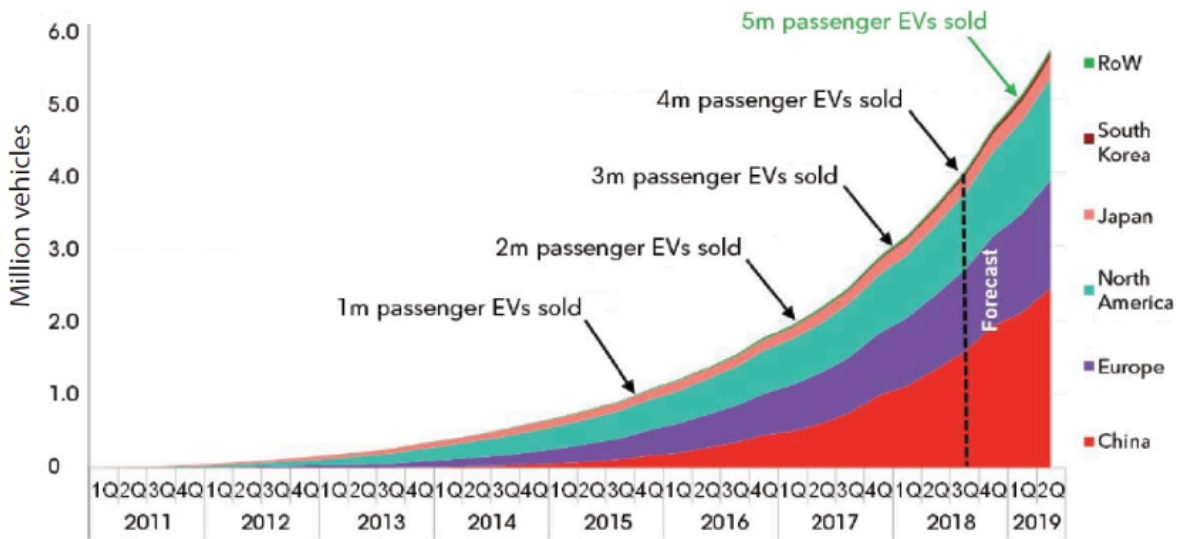

Figure 5.3: [The number of electric vehicles \(EVs\) being introduced for different regions](#) is licensed under [CC BY-NC-SA 4.0](#)

## Fuel Technology

Another key strategy for reducing GHG emissions is to utilize low-carbon fuels. Today's dominant fuel for transportation is gasoline, followed by diesel fuel and then jet fuel (Figure 5.4). All of these fuels are petroleum based and contribute significantly to CO<sub>2</sub> emissions. A number of other fuels are being introduced that are less carbon intensive, including bio-based fuels, electricity, and hydrogen. Their market share is currently quite small when compared with petroleum-based fuels. As described in Chapter 6, both electricity and hydrogen (as well as biofuels) can be utilized as effective energy carriers for transportation. Liquid biofuels have the advantage of being easily portable and having high **energy density**, like petroleum fuels. When made from crop and food wastes, liquid and gaseous biofuels have very low life cycle greenhouse gas emissions, sometimes even less than zero because waste disposal and methane leakage are avoided. With steady improvements in processing and farming, even biofuels made from crops, such as corn and sugarcane, tend to be significantly superior to petroleum fuels. As processes for converting grasses, trees, and other cellulosic material into liquids are improved, resulting in even lower life cycle greenhouse gas emissions, biofuels will likely prove the superior alternative fuel for aviation and perhaps long-haul trucking, where portability and high energy density are valued most highly.

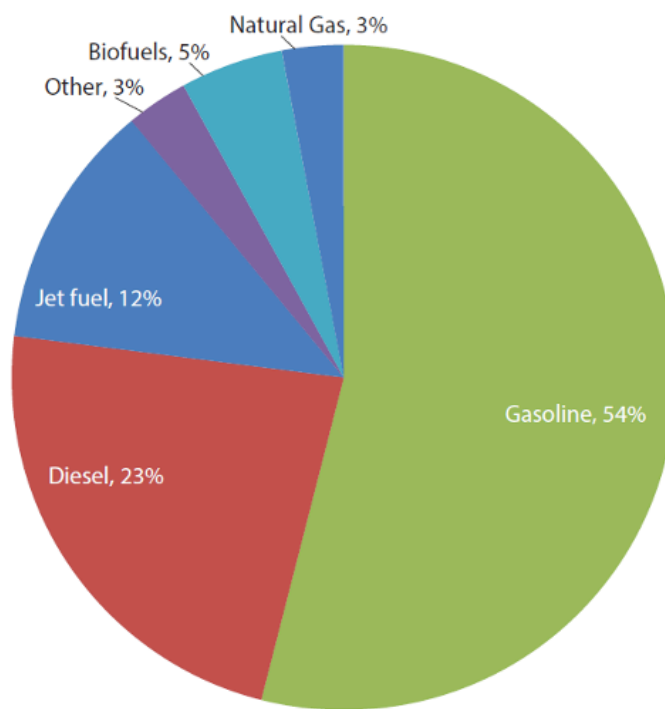

Figure 5.4: [Fuel utilization for the US transportation market, 2018](#) is licensed under [CC BY-NC-SA 4.0](#)

## LIFE CYCLE ANALYSIS

Life cycle analysis is necessary for comparing emissions of different fuels. A life cycle analysis includes all emissions from extraction through combustion, including, for example, the energy from farm machinery and carbon released from soils when growing biofuels, emissions from the operation of refineries, and the transport of fuels in tankers, pipelines, and trucks.

Table 5.1 provides rough estimates of life cycle emissions of different vehicle-fuel combinations,



compared with gasoline-powered internal combustion engine vehicles. Note that these life cycle emission comparisons (per kilometer) could vary considerably since they rely on a large number of assumptions. For example, GHG emissions for an electric vehicle depend on the carbon intensity of the electricity used to charge the vehicle. This varies widely across space and time, from close to zero carbon in regions powered predominately by nuclear and low-carbon renewable sources, to carbon emissions exceeding those from internal combustion engines in places where electricity is generated from coal.

In general, petroleum-based fuels are convenient fuels for vehicles, since they have high energy density (per unit of volume), are easily portable and refuel vehicles quickly (because they are liquid), and have energy infrastructure already in place. However, petroleum-based fuels have high GHG emissions and emit large quantities of conventional pollutants. As a society, we have grown dependent on petroleum and have become quite cost-efficient at extracting and refining fossil fuels, resulting in low prices.

In some cases, though, alternative fuels are demonstrably cheaper than petroleum, even in the US, where petroleum products tend to have lower prices than elsewhere. For example, as of 2019, a kilowatt hour costs about \$0.12 in the US on average—equivalent to about 3–4 cents per mile, an energy cost about one-third that of gasoline-powered cars. In areas with low-carbon electricity, these electric vehicles also offer significant GHG emission savings.

<i>Fuel/Feedstock</i>	<i>Percent Change</i>
Fuel cells, using hydrogen from solar	-90 to -85
Cellulosic ethanol	-90 to -40
Battery electric vehicles, electricity from low-carbon sources	-60 to -25
Hybrid electric vehicles	-40 to -30
Battery electric vehicles, current US power mix	-40 to -20
Diesel	-25 to -15
CNG from NG	-20 to 0
Gasoline	—
Battery electric vehicles, new coal plant	0 to +10

NOTE: Actual impacts could vary considerably; these estimates reflect a large number of assumptions and should be treated as illustrative.

Table 5.1: [Greenhouse Gas Emissions per Kilometer, relative to Gasoline-Powered Internal Combustion Engines, Full Energy Cycle](#) by Ramanathan, V., Aines, R., Auffhammer, M., Barth, M., Cole, J., Forman, F., et al. is licensed under [CC BY-NC-SA 4.0](#)

## FUEL USE AND EMISSIONS FROM ROAD TRAFFIC

Road transportation is a major consumer of energy and contributor to emissions of deleterious pollutants. Motorized vehicles are the second highest source of CO2 emissions in the United States. Transportation sources are causing 28% of total CO2 emissions in 2012 and 84% of that is from on

road traffic (EPA, 2014). Emissions from anthropogenic sources, particularly burning of fossil fuels, is attributed as a key factor in increase in atmospheric CO<sub>2</sub> concentration in recent years (Etheridge et al., 1996). In 2013, the United States consumed 97.1 quadrillion BTUs (Quads) of energy; 26.7 Quads (more than 25% of the total energy supply) were used in transportation sector. In doing so 173,493 million gallons of motor fuel was used including both gasoline and diesel (BTS, 2015). All major urban areas are experiencing widespread congestion due to increased demand of vehicular traffic (D. L. Schrank & Lomax, 2007). Yearly delay per commuter has increased to 42 hours in 2014 compared to 18 hours in 1982 resulting in a congestion cost of \$160 billion (D. Schrank, Eisele, Lomax, & Bak, 2015). Increased demand for travel has caused increase in number of motorized vehicles, resulting in increased congestion on roadways. Drivers are facing frequent flow disruption and increased waiting time at intersections. These factors can lead to increased emission of deleterious pollutants such as carbon dioxide (CO<sub>2</sub>), carbon monoxide (CO), nitrogen oxides (NO<sub>x</sub>), hydrocarbons (HCs) (Oduyemi & Davidson, 1998). Oversaturation is the main contributor to predicted total emissions for CO and HC (Smit, 2006). Increased emission from congestion may be a result of more idling time, and more acceleration and deceleration events associated with stop and go conditions.

#### **Techniques for reducing fuel use and emissions from road traffic**

There have been many improvements in prevention and control of mobile source emissions in recent years such as modifying fuel, vehicle operation, engine design, behavior, regular maintenance, and most commonly by exhaust gas treatment. Improvements such as low sulfur fuels, computerized fuel metering, electronic ignition, air injection, exhaust gas recirculation, and 3-way catalytic converters have substantially reduced emissions on an individual vehicle basis (Faiz, Weaver, & Walsh, 1996). During hard acceleration events emissions of HC and CO can increase as vehicle engines operate in a fuel rich mode (Alkidas, 2007). Emissions of PM and HC can increase under deceleration due to the presence of unburned fuel (Cappiello, 2002). A common emissions mitigation measure considered by transportation planners is to enhance the capacity of the roadways. But the effect of capacity augmentation on reduction of emissions is not well quantified; such augmentation may increase **induced travel** resulting in quick decrease of initial emission reduction benefits (Noland & Quddus, 2006).

Many transportation planning and operations strategies are planned and being implemented to reduce this problem (Eliasson, Hultkrantz, Nerhagen, & Rosqvist, 2009; Tonne, Beevers, Armstrong, Kelly, & Wilkinson, 2008). Changing intersection design, traffic signal design, freeway metering technologies are some examples of operational strategies that are practiced (Greene & Plotkin, 2011). The United States Environmental Protection Agency (USEPA) is implementing 'Tier 3 Motor Vehicle Emissions and Fuel Standard' from 2017; which is going to be an important shift in standards for 'regulatory classes' that follows EPA's adoption of 'Tier 2' program in 2000. By the year 2030, 'Tier 3' class of vehicles are expected to reduce onroad NO<sub>x</sub>, VOC, CO, SO<sub>2</sub>, Benzene emissions by 25%, 16%, 24%, 56%, 26% respectively. Furthermore, the phasing in of more stringent vehicle emission regulations, and fleet turnover to lower emitting vehicles, can be a factor in reducing on-road emissions of regulated pollutants such as CO, NO<sub>x</sub>, and HC.

In contrast to all the above mentioned techniques, an alternative and complementary approach could be the use of technologies to target the behavioral and system factors to improve the overall energy efficiency without altering the mechanical efficiency of each mode (car, bus, truck). Passenger vehicles run with 60% unutilized capacity (BTS, 2015); improving occupancy can make a big

difference in total travel demand. Online taxi and ride sharing services such as Waze, Uber, RubyRide, Zipcar, Lyft has provided travelers with unique flexibility in terms of mode choice. Inefficient driving styles cause loss of 45% of the optimal fuel economy (Sivak & Schoettle, 2012). Emergence of communication technologies such as cellular and internet networks and social networks such as Facebook, Twitter has made it possible to influence travel behavior of individuals. Moreover, congestion arising from suboptimal route choice and oversaturation increases transportation energy use up to 33% (Roughgarden, 2012). Informed travel mode, route, and departure time choice is possible through real time travel information services such as Google Maps, INRIX and personalized navigation systems. A practical framework with real time response capability for monitoring, communicating, incentivizing, and controlling trip making and driving behavior attributes can make energy efficiency an integral part of the optimized transportation network.

## INTEGRATED TRAFFIC SIMULATION AND ENERGY USE-EMISSIONS ESTIMATION

Traffic simulation models at different levels of complexity and scales have been and are being developed for assessing energy use-emissions impact. To conduct project-level traffic environmental impact studies, microscopic emissions models are often adopted in transportation evaluation projects (Ahn, Rakha, Trani, & Van Aerde, 2002; Nam, Brazil, & Sutulo, 2002; Stathopoulos & Noland, 2003). Microscopic traffic simulation tools have been widely used to generate vehicle emissions estimates by evaluating driving speed and acceleration characteristics/profiles on a vehicle-by-vehicle and second-by-second basis. Although a high-fidelity traffic simulator is desirable for analyzing individual movement delays and facilities with complex geometric configurations, microscopic simulation can be computationally intensive and typically requires a wide range of detailed geometric data and driving behavior parameters, which can be difficult to calibrate, especially for the purpose of producing high fidelity emissions estimates. This has limited their applicability to small- and medium-scale corridors.

Alternatively, many organizations have utilized post-processing techniques for estimating vehicle emissions from their travel demand model results. Large scale air pollution maps are generally produced by using static estimates of average traffic and weather conditions. Most of the existing research for regional or city level emission assessment have used historic O-D matrices (Gualtieri & Tartaglia, 1998), land use transport models (Lautso & Toivanen, 1999), travel demand models (Karppinen et al., 2000), traffic assignment modules (Namdeo, Mitchell, & Dixon, 2002). These estimates lack the sensitivity of dynamic vehicular travel demand and cannot reflect temporal fluctuations of road conditions.

Recognizing that conventional static traffic assignment models are not sensitive to the dynamic interaction of vehicular travel demand and time-dependent road conditions, planning practitioners have increasingly recognized the capabilities of mesoscopic Dynamic Traffic Assignment (DTA) models. However, many planners and engineers are still concerned that DTA tools, typically based on fine-grained network representations, are computationally intensive and lack model components/details necessary for accurately representing high-fidelity traffic dynamics. Differences in resolution between traffic simulation and emissions estimation models is a barrier to integrating them into one framework. In recent years, a multi-resolution modeling approach has been exploited by many practitioners. Typically, this approach aims to integrate many existing simulation tools in a loosely coupled software platform that can provide multiple levels of modeling detail regarding network dynamics and traveler/driver choices. For example, in a subarea study, one can simply extract vehicle

path data from a (macroscopic/mesoscopic) DTA tool for use in a microscopic simulation model (e.g. VISSIM, Paramics, TRANSIMS) to generate second-by-second vehicle speed and acceleration outputs for microscopic emissions or mobility-related analysis.

Estimation of emissions is dependent on the simulated driving activity such as instantaneous speeds and accelerations. Therefore, the accuracy of fuel use and emissions estimation hinge on the accuracy of traffic simulation. Traditional traffic simulations are focused on the mobility and safety aspects of the network. In contrast, traffic simulations to assess fuel use and emissions are focused on the capability of the model to emulate driving activity parameters properly. In addition to the fundamental difference in simulation purpose, a few functionality and compatibility issues are equally important in energy use and emissions estimation. The simulator framework can be visualized as Figure has two different modules namely a traffic simulation module and an emissions estimation module. Data flow between these two modules should be consistent and uninterrupted in ideal conditions.

There have been many efforts in the past to couple an emission model with a traffic simulator either manually or directly. AIMSUN has been used with a European modal emissions model, VERSIT+ (Ligterink & Lange, 2009). MOBILE6 emissions model has been coupled with EMME/2 and PARAMICS (Bartin et al., 2007). MOVES emission model has been used with PARAMICS, DynusT, and VISSIM (Lin, Chiu, Vallamsundar, & Bai, 2011b; Song et al., 2012; Xie et al., 2011). Dynamic linkage of traffic and emissions models is challenging and can lead to significantly longer run times. Evaluation for a large-scale network is a trade-off between estimation accuracy and computational tractability. Therefore, it is a challenge to properly estimate emissions-related impacts that is greatly exceeded by the imprecision and/or inaccuracy of the estimate.

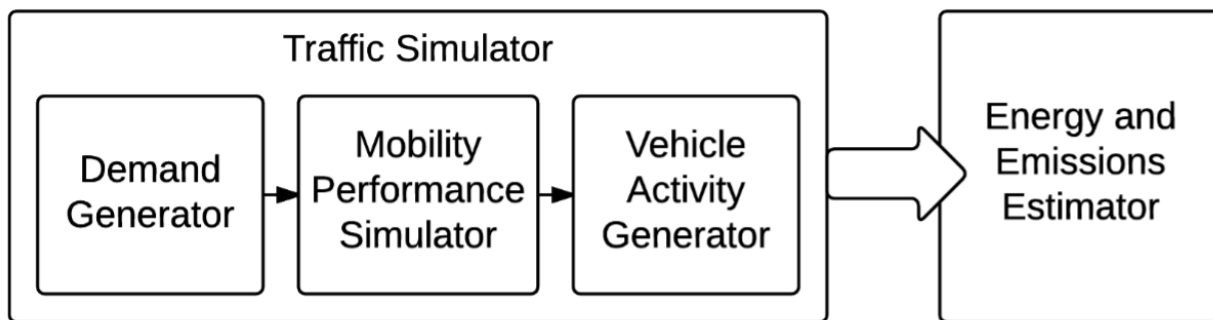

Figure 5.5: Modules of integrated traffic simulation and emission estimation. Produced with permission from the author Tanvir (2018).

Multi-resolution modeling system such as a mesoscopic DTA has a relatively low simulation resolution (e.g. 6 second update interval), while microscopic traffic simulators typically use 0.1 seconds as the simulation interval. To ensure theoretical convergence of the integrated models, it is necessary to use multiple iterations between different simulation/assignment components to determine the mobility and emission impact of high-level demand and traveler behaviors. However, internal discrepancies between different modeling resolutions make tight interconnections and consistent modeling extremely challenging.

## Energy use and emissions estimation

Effective tools to estimate emissions for different scenarios are required to assess the effect of these strategies at different spatial and temporal resolution. There are several emissions models available that can estimate vehicle emissions for the prediction and management of air pollution levels near roadways. These models use information on weather, fuel type, fleet composition, vehicle type, and activity schedule as input.

For planning purposes, average speed and flow based models have been used for a long time. However, these models cannot adequately represent the dynamic effects of driving styles. Average speed based models use predetermined speed trajectories upon which relationships between cycle or link-based average-speed and average emission rates are estimated (e.g. MOBILE (USEPA, 2007), EMFAC (CARB, 2002), COPERT (Ntziachristos et al., 2000)). US Environmental Protection Agency (EPA) have developed MOVES that can take into account a second-by-second vehicle speed trajectory (Chamberlin, Swanson, Talbot, Dumont, & Pesci, 2011). There are other models, such as CMEM (An, Barth, Norbeck, & Ross, 1997), that also consider operating modes in estimating emissions. Thus, MOVES is attractive in being able to represent a wide range of driving cycles for any user specified speed trajectory.

## Vehicle specific power (VSP) based estimation

VSP is a well-evaluated and widely used quantitative indicator of engine power demand that is an excellent predictor of vehicle fuel use and that is also highly correlated with vehicle tailpipe exhaust emissions for a wide range of pollutants (Jimenez-Palacios, 1998). VSP is a function of vehicle speed, road grade, and acceleration which accounts for kinetic energy, rolling resistance, aerodynamic drag, and gravity (Zhai, Frey, Roupail, Goncalves, & Farias, 2009). It is usually reported as power required per mass of the vehicle (for example: kilowatts per ton). Calculated VSP is categorized into different operating mode bins by speed and VSP ranges to estimate emissions factor for vehicles. Therefore, VSP is a parameter with important practical application. But accurate determination of VSP depends on proper quantification of measured vehicle operating characteristics, such as speed, acceleration, road grade etc. Microscopic traffic characteristics e.g. speed, acceleration, headway etc. are highly dependent on the roadway, traffic, driver behavior characteristics.

VSP is usually estimated using developed equations for different classes of vehicles. According to MOVES the equation to calculate VSP is expressed as

$$VSP = \left(\frac{A}{M}\right)v + \left(\frac{B}{M}\right)v^2 + \left(\frac{C}{M}\right)v^3 + (a + \sin(\Phi))v$$

Where: A, B and C refer to the rolling term, rotating term and the drag term respectively. M is the vehicle mass,  $v$  is the vehicle speed,  $a$  is vehicle acceleration and  $\Phi$  is road grade. The parameters are different for each vehicle type.

MOVES provides default coefficients for different group of vehicles. Derivation of these coefficients is based on chassis dynamometer tests. The VSP formulation for light-weight vehicles provided by MOVES is

$$VSP = (A * v + B * v^2 + C * v^3 + m * v * a) / m$$

VSP = vehicle specific power, kW/ton

$v$  = speed at time  $t$ , m/s ;  $a$  = acceleration at time  $t$ , m/s<sup>2</sup>

A = rolling resistance coefficient = 0.1565 kW-sec/m

$B = \text{rotational resistance coefficient} = 2.002 \times 10^{-3} \text{ kW-sec}^2/\text{m}^2$

$C = \text{aerodynamic drag coefficient} = 4.926 \times 10^{-4} \text{ kW-sec}^3/\text{m}^3$

$m = \text{vehicle mass} = 1.479 \text{ ton.}$

### **EPA MOVES model**

On March 2, 2010, USEPA announced the official release of the Motor Vehicle Emissions Simulator (MOVES2010) for use in state implementation plan (SIP) submissions to EPA and regional emission analysis for transportation conformity (Koupal, Cumberworth, Michaels, Beardsley, & Brzezinski, 2002). It replaced MOBILE 6.2 model where vehicle emissions rates represent averages over a driving schedule with defined average speed. MOVES2010 considers the relative time spent and emissions rate in vehicle speed and vehicle specific power bins (Fujita et al., 2012). Except for braking and idling, these OpMode bins are stratified by 21 speed ranges (<25 mph, 25 to 50 mph, and >50 mph) and by Vehicle Specific Power (VSP) (Koupal, Michaels, Cumberworth, Bailey, & Brzezinski, 2002; Vallamsundar & Lin, 2011). The main purpose of this tool is to quantitatively predict emissions from mobile sources for a wide range of user-defined parameters e.g. vehicle type, time periods, geographical areas, pollutants, vehicle operating characteristics and road type (EPA, 2012). Therefore, MOVES is a significant improvement in the state-of-art for emissions estimation.

The inputs from traffic simulation software can be linked to MOVES in three different formats:

1. Average speeds for the links of the network (similar to MOBILE)
2. Link driving schedule (LDS) for each link of the network. LDS is a time dependent speed profile for a particular link. Generally LDS is selected for a representative vehicle or by sampling.
3. Operating mode distribution of vehicles of the link.

However, MOVES is computationally intensive. Some investigators have attempted to use traffic simulation output for vehicle speed trajectories as input to MOVES, leading to time consuming computations for evaluation of different traffic management strategy scenarios.

### **Simplified emissions estimator - MOVESLite**

As an alternative approach, a reduced form version of MOVES, referred to as MOVES Lite, has been recently developed (Frey & Liu, 2013). MOVES Lite is based on the same computational structure as MOVES with respect to Op Mode bins and, therefore, is capable of estimating emissions for any specified speed trajectory. MOVES Lite is less computational intensive than MOVES because it is calibrated to a base cycle and employs a cycle correction factor to adjust for differences in emission rates between any cycle of interest and the base cycle. MOVES Lite is based on a more limited set of vehicle types and pollutants than MOVES. Since traffic simulations are often for periods of a few hours, MOVES Lite does not take into account variations in factors such as fuel properties, inspection and maintenance programs, and ambient conditions that do not change substantially or at all during such short periods of time. MOVES Lite is 3,000 times faster and can produce emissions estimates within  $\pm 5\%$  deviation compared to MOVES.

Because many factors where MOVES is sensitive are approximately constant during the time period of a typical simulation, there is no need to run MOVES in its entirety for every link in a network. Furthermore, because MOVES estimates emission factors based on weighted combinations

of OpMode bins, a similar approach can be used as part of a simplified model that can be directly coded as part of a traffic simulation model. MOVESLite harnesses these benefits to develop a less computationally intensive vehicle emission estimation module. The conceptual model of MOVESLite is based on (a) base emission rate for site-specific characteristics (b) a cycle correction factor for speed trajectories and OpMode bin emission rates. The cycle correction factor is calculated using the following equation

$$\text{CCF}_{p,c,a,v} = \left( \frac{\left( \sum_m f_m^c \right) \times \text{ER}_{p,a,v,m}}{\left( \sum_m f_m^b \right) \times \text{ER}_{p,a,v,m}} \right) \left( \frac{V^b}{V^c} \right)$$

Where,

$\text{ER}_{p,a,v,m}$  = default emission rate for pollutant p, age a, vehicle type v, in operating mode bin m, gram/hour

$f_m^c$  = fraction of time in OpMode bin m in cycle c

$f_m^b$  = fraction of time in OpMode bin m for base cycle b

$V^c$  = cycle average speed for cycle c, mph

$V^b$  = cycle average speed for base cycle b, mph

The base emissions rate is then corrected for the simulated cycle using the following equation

$$\text{CE}_{p,c} = \sum_v \left\{ \left[ \sum_a (\text{EF}_{p,b,a,v} \times \text{CCF}_{p,c,a,v} \times f_{a,v}) \right] \times f_v \right\}$$

Where,

$\text{CE}_{p,c}$  = cycle average emission factor for any arbitrary driving cycle c, for pollutant p, for a fleet of vehicles with mixed types and ages, gram/mi

$\text{ER}_{p,b,a,v}$  = base emission rate for base cycle b, age a, vehicle type v, and pollutant p, gram/mi

$\text{CCF}_{p,c,a,v}$  = cycle correction factor for driving cycle c, age a, vehicle type v, and pollutant p

$f_{a,v}$  = age fraction for age a and vehicle type v

$f_v$  = vehicle type fraction for vehicle type v

c = cycle c

b = base cycle

p = pollutant

Comparison of the 2 models across similar criteria shown in Table 5.2 and Table 5.3.

**Table 5.2: Performance of MOVES across different functional criteria**

<b>Criterion</b>	<b>MOVES</b>
Accuracy	Accurate comparing with empirical emission factors.
Runtime	Relatively slow.
Requirement for Input	Substantial input data requirements.
Requirement for Platform	Need to install MOVES package, JAVA, and MySQL.
Connection with TDM and TSM	Difficult to be coupled into TDM or TSM.
Usability	Errors, warnings arise frequently, especially for beginning users.
Time consuming procedures	Adjust fuel property, temperature, humidity, air conditioning use, and I/M program for each link in the network.
Vehicle dynamic data	Second by second data, or OpMode distribution
Vehicle Types	13 Vehicle types: Passenger Car, Passenger Truck, Refuse Truck, Single-Unit Short-Haul, Truck Single-Unit Long-Haul Truck, Motor Home, Intercity Bus, Transit Bus, School Bus, Combination Short-Haul Truck, Combination Long-Haul Truck, Motorcycle
Adjusted emission rate map (reflecting vehicle distribution and climate)	Yes, took vehicle distribution and weather condition (temperature and humidity) into account.

**Table 5.3. Performance of MOVES lite across different performance criteria**

<b>Criterion</b>	<b>MOVES lite</b>
Accuracy	Within $\pm 5\%$ errors comparing with MOVES.
Runtime	3000 times faster than MOVES.
Requirement for Input	Limited input data requirements.
Requirement for Platform	Can be run in MS EXCEL or MATLAB. It has a computational algorithm.
Connection with TDM and TSM	Can be integrated into TDM or TSM easily.
Usability	User-friendly.
Time consuming procedures	Set fuel property, temperature, humidity, air conditioning use, and I/M program constant by link in the network.
Vehicle dynamic data	Same as MOVES
Vehicle Types	For U.S. based model: Five vehicle types that comprise of more than 95% of the fleet: Passenger Cars, Passenger Trucks, Light Commercial Trucks, Single Unit Short Haul Trucks, and Combination Long Haul Trucks.
Adjusted emission rate map (reflecting vehicle distribution and climate)	Yes, took vehicle distribution into account.

### Key Takeaways

- Different energy pathways exist to meet the same transportation needs.



- Combinations of vehicle technologies and fuel technologies result in change in total energy consumption and emissions.
- It is important to analyze the life-cycle of a vehicle-fuel combination to ascertain the energy efficiency of the technology.
- Microsimulation is a computationally intensive way to estimate energy consumption from road traffic, macroscopic simulation may be too crude, and mesoscopic simulation is a balance between the two.

## Self-Test



An interactive H5P element has been excluded from this version of the text. You can view it online here: <https://uta.pressbooks.pub/sustainablemobility/?p=225#h5p-5>

## GLOSSARY: KEY TERMS

**Carbon intensity:** A measure of carbon dioxide and other greenhouse gases (CO<sub>2</sub>e) per unit of activity, like generating a product

**Energy density:** The amount of energy stored in a given system, substance, or region of space per unit volume.

**Energy efficient:** Use of less energy to perform the same task or produce the same result.

**Induced travel:** Adding roadway capacity actually increases network-wide vehicle miles traveled (VMT) by a nearly equivalent proportion within a few years, reducing or negating any initial congestion relief. That increase in VMT is called “induced travel”

## MEDIA ATTRIBUTIONS

### Figures

- Figure 5.1: [Bending the Curve: Climate Change Solutions](#) by Ramanathan, V., Aines, R., Auffhammer, M., Barth, M., Cole, J., Forman, F., et al. is licensed under [CC BY-NC-SA 4.0](#)
- Figure 5.2: [Average passenger car GHG emissions normalized by distance traveled for different regions](#) by Ramanathan et al. (2019) is licensed under [CC BY-NC-SA 4.0](#)
- Figure 5.3: [The number of electric vehicles \(EVs\) being introduced for different regions](#)

is licensed under [CC BY-NC-SA 4.0](#)

- Figure 5.4: [Fuel utilization for the US transportation market, 2018](#) is licensed under [CC BY-NC-SA 4.0](#)
- Figure 5.5: Modules of integrated traffic simulation and emission estimation. Produced with permission from the author Tanvir (2018).

#### Tables

- Table 5.1: [Greenhouse Gas Emissions per Kilometer, relative to Gasoline-Powered Internal Combustion Engines, Full Energy Cycle](#) by Ramanathan, V., Aines, R., Auffhammer, M., Barth, M., Cole, J., Forman, F., et al. is licensed under [CC BY-NC-SA 4.0](#)

## REFERENCES

- Ahn, K., Rakha, H., Trani, A., & Van Aerde, M. (2002). Estimating vehicle fuel consumption and emissions based on instantaneous speed and acceleration levels. *Journal of Transportation Engineering*, 128(2), 182-190.
- Alkidas, A. C. (2007). Combustion advancements in gasoline engines. *Energy Conversion and Management*, 48(11), 2751-2761.
- An, F., Barth, M., Norbeck, J., & Ross, M. (1997). Development of comprehensive modal emissions model: Operating under hot-stabilized conditions. *Transportation Research Record: Journal of the Transportation Research Board*, 1587(1), 52-62.
- Barth, M., & Boriboonsomsin, K. (2009). Traffic congestion and greenhouse gases. *ACCESS Magazine*, 1(35)
- Bartin, B., Mudigonda, S., & Ozbay, K. (2007). Impact of electronic toll collection on air pollution levels: Estimation using microscopic simulation model of large-scale transportation network. *Transportation Research Record: Journal of the Transportation Research Board*, 2011(1), 68-77.
- BTS. (2015). *State transportation statistics 2015*. Washington DC: US Department of Transportation, Bureau of Transportation Statistics.
- Bureau of Transportation Statistics. (2013). National transportation statistics (table 1-11: Number of U.S. aircraft, vehicles, vessels, and other conveyances). Retrieved from [http://www.bts.gov/publications/national\\_transportation\\_statistics/html/table\\_01\\_11.html](http://www.bts.gov/publications/national_transportation_statistics/html/table_01_11.html)
- Cambridge Systematics. (1996). *Quantifying air quality and other benefits and costs of transportation control measures*. ( No. Task 1 Report. Project 8-33.). Washington D.C: National Cooperative Highway Research, Transportation Research Board.
- Capiello, A. (2002). *Modeling traffic flow emissions* (MS Thesis).
- CARB. (2002). *EMFAC 2002, california air resources board's emission inventory*. ( No. Series,

September).California Air Resource Board.

- Chamberlin, R., Swanson, B., Talbot, E., Dumont, J., & Pesci, S. (2011). Analysis of MOVES and CMEM for evaluating the emissions impact of an intersection control change. Paper presented at the *Transportation Research Board 90th Annual Meeting*, (11-0673)
- Daganzo, C. F. (2006). In traffic flow, cellular automata = kinematic waves. *Transportation Research Part B: Methodological*, 40(5), 396-403. doi://[dx.doi.org/prox.lib.ncsu.edu/10.1016/j.trb.2005.05.004](https://doi.org/prox.lib.ncsu.edu/10.1016/j.trb.2005.05.004)
- De Vlieger, I., De Keukeleere, D., & Kretzschmar, J. G. (2000). Environmental effects of driving behaviour and congestion related to passenger cars. *Atmospheric Environment*, 34(27), 4649-4655.
- Eliasson, J., Hultkrantz, L., Nerhagen, L., & Rosqvist, L. S. (2009). The stockholm congestion-charging trial 2006: Overview of effects. *Transportation Research Part A: Policy and Practice*, 43(3), 240-250.
- EPA. (1999). *Regulatory announcements*. Ann Arbor, MI: United States Environmental Protection Agency.
- EPA. (2008). *Integrated science assessment for oxides of nitrogen – health criteria (final report)*. ( No. EPA/600/R-08/071). Washington D.C.: U.S. Environmental Protection Agency.
- EPA. (2010). *Integrated science assessment for carbon monoxide (final report)*. ( No. EPA/600/R-09/019F). Washington D.C.: U.S. Environmental Protection Agency.
- EPA. (2012). *User guide for MOVES2010b*. ( No. EPA-420-B-12-001b).United State Environmental Protection Agency.
- EPA. (2014). *Inventory of U.S. greenhouse gas emissions and sinks: 1990-2012*. ( No. EPA 430-R-14-003). Washington D.C.: U.S. EPA.
- Etheridge, D. M., Steele, L. P., Langenfelds, R. L., Francey, R. J., Barnola, J., & Morgan, V. I. (1996). Natural and anthropogenic changes in atmospheric CO<sub>2</sub> over the last 1000 years from air in antarctic ice and firn. *Journal of Geophysical Research: Atmospheres (1984–2012)*, 101(D2), 4115-4128.
- Faiz, A., Weaver, C. S., & Walsh, M. P. (1996). *Air pollution from motor vehicles: Standards and technologies for controlling emissions* World Bank-free PDF.
- Frey, H. C., Zhai, H., & Roupail, N. M. (2009). Regional on-road vehicle running emissions modeling and evaluation for conventional and alternative vehicle technologies. *Environmental Science & Technology*, 43(21), 8449-8455. doi:10.1021/es900535s; 10.1021/es900535s
- Frey, H. C., & Liu, B. (2014). Development and evaluation of a simplified version of MOVES for coupling with a traffic simulation model. *Proceedings, 91st Annual Meeting of the Transportation Research Board*,
- Frey, H. C., Roupail, N. M., Unal, A., & Colyar, J. D. (2001). No title. *Emissions Reduction through Better Traffic Management: An Empirical Evaluation Based upon on-Road Measurements*,
- Frey, H. C., Yazdani-Boroujeni, B., Hu, J., Liu, B., & Jiao, W. (2013). Field measurements of 1996 to 2013 model year light duty gasoline vehicles. Paper presented at the *Proceedings, 106th*

*Annual Conference, Air & Waste Management Association, Chicago, IL,*

- Fujita, E. M., Campbell, D. E., Zielinska, B., Chow, J. C., Lindhjem, C. E., DenBleyker, A., . . . Lawson, D. R. (2012). Comparison of the MOVES2010a, MOBILE6. 2, and EMFAC2007 mobile source emission models with on-road traffic tunnel and remote sensing measurements. *Journal of the Air & Waste Management Association*, 62(10), 1134-1149.
- Gordon, P., Kumar, A., & Richardson, H. W. (1990). Peak-spreading: How much? *Transportation Research Part A: General*, 24(3), 165-175.
- Greene, D. L., & Plotkin, S. E. (2011). Reducing greenhouse gas emission from US transportation. *Arlington: Pew Center on Global Climate Change*,
- Gualtieri, G., & Tartaglia, M. (1998). Predicting urban traffic air pollution: A GIS framework. *Transportation Research Part D: Transport and Environment*, 3(5), 329-336.
- Health Effects Institute. Panel on the Health Effects of Traffic-Related Air Pollution. (2010). *Traffic-related air pollution: A critical review of the literature on emissions, exposure, and health effects* Health Effects Institute.
- Hurdle, V. F., & Son, B. (2000). Road test of a freeway model. *Transportation Research Part A: Policy and Practice*, 34(7), 537-564. doi://[dx.doi.org/prox.lib.ncsu.edu/10.1016/S0965-8564\(99\)00031-2](https://doi.org/prox.lib.ncsu.edu/10.1016/S0965-8564(99)00031-2)
- Jimenez-Palacios, J. L. (1998). *Understanding and quantifying motor vehicle emissions with vehicle specific power and TILDAS remote sensing*
- Karppinen, A., Kukkonen, J., Elolähde, T., Konttinen, M., Koskentalo, T., & Rantakrans, E. (2000). A modelling system for predicting urban air pollution: Model description and applications in the helsinki metropolitan area. *Atmospheric Environment*, 34(22), 3723-3733.
- Koupal, J., Cumberworth, M., Michaels, H., Beardsley, M., & Brzezinski, D. (2002). Design and implementation of MOVES: EPA's new generation mobile source emission model. *Ann Arbor, 1001*, 48105.
- Koupal, J., Michaels, H., Cumberworth, M., Bailey, C., & Brzezinski, D. (2002). (2002). EPA's plan for MOVES: A comprehensive mobile source emissions model. Paper presented at the *Proceedings of the 12th CRC on-Road Vehicle Emissions Workshop, San Diego, CA*,
- Krzyzanowski, M., Kuna-Dibbert, B., & Schneider, J. (2005). *Health effects of transport-related air pollution* World Health Organization Copenhagen.
- Lautso, K., & Toivanen, S. (1999). SPARTACUS system for analyzing urban sustainability. *Transportation Research Record: Journal of the Transportation Research Board*, 1670(1), 35-46.
- Ligterink, N. E., & Lange, R. d. (2009). Refined vehicle and driving-behaviour dependencies in the VERSIT emission model. Paper presented at the *ETAPP Symposium*,
- Lin, J., Chiu, Y., Vallamsundar, S., & Bai, S. (2011a). Integration of MOVES and dynamic traffic assignment models for fine-grained transportation and air quality analyses. Paper presented at the *Integrated and Sustainable Transportation System (FISTS), 2011 IEEE Forum On*, 176-181.
- Lin, J., Chiu, Y., Vallamsundar, S., & Bai, S. (2011b). Integration of MOVES and dynamic traffic assignment models for fine-grained transportation and air quality analyses. Paper presented

at the *Integrated and Sustainable Transportation System (FISTS), 2011 IEEE Forum On*, 176-181.

- Lomax, T., Turner, S., Shunk, G., Levinson, H. S., Pratt, R. H., Bay, P. N., & Douglas, G. B. (1997). NCHRP report 398: Quantifying congestion. *Transportation Research Board, National Research Council, Washington, DC*,
- Mahmassani, H. S., & Liu, Y. (1999). Dynamics of commuting decision behaviour under advanced traveller information systems. *Transportation Research Part C: Emerging Technologies*, 7(2), 91-107.
- Meyer, M. D. (1999). Demand management as an element of transportation policy: Using carrots and sticks to influence travel behavior. *Transportation Research Part A: Policy and Practice*, 33(7), 575-599.
- Mitchell, G., Namdeo, A., Lockyer, J., & May, A. D. (2002). The impact of road pricing and other strategic road transport initiatives on urban air quality. Paper presented at the *Proceedings of the 8th International Conference on Urban Transport and the Environment in the 21st Century*, 481-490.
- Nam, E. K., Brazil, H., & Sutulo, S. (2002) The integration of a fuel rate based modal emissions model (CMEM modified) into the VISSIM microscopic traffic model – inventory comparison with MOBILE6 in southfield michigan. . *Proceedings of the 12th CRC on-Road Vehicle Emissions Workshop*,
- Namdeo, A., Mitchell, G., & Dixon, R. (2002). TEMMS: An integrated package for modelling and mapping urban traffic emissions and air quality. *Environmental Modelling & Software*, 17(2), 177-188.
- Newell, G. F. (1993). A simplified theory of kinematic waves in highway traffic: (I) general theory; (ii) queuing at freeway bottlenecks; (iii) multi-dimensional flows . *Transportation Research Part B: Methodological*, 27(4), 281-313.
- Newell, G. F. (2002). A simplified car-following theory: A lower order model. *Transportation Research Part B: Methodological*, 36(3), 195-205.
- Ni, D., Leonard, J. D., & Williams, B. M. (2006). The network kinematic waves model: A simplified approach to network traffic. *Journal of Intelligent Transportation Systems*, 10(1), 1-14.
- Noland, R. B., & Quddus, M. A. (2006). Flow improvements and vehicle emissions: Effects of trip generation and emission control technology. *Transportation Research Part D: Transport and Environment*, 11(1), 1-14.
- Ntziachristos, L., Samaras, Z., Eggleston, S., Gorissen, N., Hassel, D., & Hickman, A. J. (2000). Copert iii. *Computer Programme to Calculate Emissions from Road Transport, Methodology and Emission Factors (Version 2.1)*, European Energy Agency (EEA), Copenhagen,
- Oduyemi, K., & Davidson, B. (1998). The impacts of road traffic management on urban air quality. *Science of the Total Environment*, 218(1), 59-66.
- Ramanathan, V., Aines, R., Auffhammer, M., Barth, M., Cole, J., Forman, F., et al. (2019). *Bending the Curve: Climate Change Solutions*. Location: Regents of the University of California. Editor: V. Ramanathan. Co-Editors: Adam Millard-Ball; Michelle Niemann; Scott Friese. Book published by the Regents of the Univ of California. Retrieved from

<https://escholarship.org/uc/item/6kr8p5rq>. 815pp <https://creativecommons.org/licenses/by-nc-sa/4.0/>

- Roughgarden, T. (2012). The price of anarchy in games of incomplete information. Paper presented at the *Proceedings of the 13th ACM Conference on Electronic Commerce*, 862-879.
- Samaranayake, S., Glaser, S., Holstius, D., Monteil, J., Tracton, K., Seto, E., & Bayen, A. (2014). Real-Time estimation of pollution emissions and dispersion from highway traffic. *Computer-Aided Civil and Infrastructure Engineering*, 29(7), 546-558.
- Schrank, D. L., & Lomax, T. J. (2007). *The 2007 urban mobility report* Texas Transportation Institute, Texas A & M University.
- Schrank, D., Eisele, B., Lomax, T., & Bak, J. (2015). *2015 urban mobility scorecard*. Texas: Texas A&M Transportation Institute and INRIX, Inc.
- Sivak, M., & Schoettle, B. (2012). Eco-driving: Strategic, tactical, and operational decisions of the driver that influence vehicle fuel economy. *Transport Policy*, 22, 96-99.
- Sjodin, A., Persson, K., Andreasson, K., Arlander, B., & Galle, B. (1998). On-road emission factors derived from measurements in a traffic tunnel. *International Journal of Vehicle Design*, 20(1), 147-158.
- Smit, R. (2006). *An examination of congestion in road traffic emission models and their application to urban road networks*
- Song, G., Yu, L., & Zhang, Y. (2012). Applicability of traffic microsimulation models in vehicle emissions estimates. *Transportation Research Record: Journal of the Transportation Research Board*, 2270(1), 132-141.
- Stathopoulos, F. G., & Noland, R. B. (2003). Induced travel and emissions from traffic flow improvement projects. *Transportation Research Record: Journal of the Transportation Research Board*, 1842(1), 57-63.
- Tanvir, S., Karmakar, N., Roupail, N. M., & Schroeder, B. J. (2016). Modeling freeway work zones with mesoscopic dynamic traffic simulator: Validation, gaps, and guidance. *Transportation Research Record: Journal of the Transportation Research Board*, (2567), 122-130.
- Tanvir, Shams. *Modeling and Simulation of Driving Activity from an Energy Use-Emissions Perspective*. North Carolina State University, 2018.
- Tonne, C., Beevers, S., Armstrong, B., Kelly, F., & Wilkinson, P. (2008). Air pollution and mortality benefits of the london congestion charge: Spatial and socioeconomic inequalities. *Occupational and Environmental Medicine*, 65(9), 620-627.
- Twigg, M. V. (2007). Progress and future challenges in controlling automotive exhaust gas emissions. *Applied Catalysis B: Environmental*, 70(1), 2-15.
- USEPA. (2007). *MOBILE 6 vehicle emission modelling software and documentation*. (). Washington, DC: US Environmental Protection Agency.
- Vallamsundar, S., & Lin, J. (. (2011). MOVES versus MOBILE. *Transportation Research Record: Journal of the Transportation Research Board*, 2233(1), 27-35.
- Xie, Y., Chowdhury, M. A., Bhavsar, P., & Zhou, Y. (2011). An integrated tool for modeling the

impact of alternative fueled vehicles on traffic emissions: A case study of greenville, south carolina. Paper presented at the *Transportation Research Board 90th Annual Meeting*, (11-3880)

- Yperman, I. (2007). *The link transmission model for dynamic network loading* (Ph.D. Thesis).
- Zhai, H., Frey, H. C., Roupail, N. M., Goncalves, G. A., & Farias, T. L. (2009). Comparison of flexible fuel vehicle and life-cycle fuel consumption and emissions of selected pollutants and greenhouse gases for ethanol 85 versus gasoline. *Journal of the Air & Waste Management Association* (1995), 59(8), 912-924.
- Zhang, K., & Batterman, S. A. (2009). Time allocation shifts and pollutant exposure due to traffic congestion: An analysis using the national human activity pattern survey. *Science of the Total Environment*, 407(21), 5493-5500.
- Zhou, X., Tanvir, S., Lei, H., Taylor, J., Liu, B., Roupail, N. M., & Christopher Frey, H. (2015). Integrating a simplified emission estimation model and mesoscopic dynamic traffic simulator to efficiently evaluate emission impacts of traffic management strategies. *Transportation Research Part D: Transport and Environment*, 37, 123-136. doi://dx.doi.org/10.1016/j.trd.2015.04.013

#### ATTRIBUTIONS

- [Bending the Curve: Climate Change Solutions](#) by Ramanathan, V., Aines, R., Auffhammer, M., Barth, M., Cole, J., Forman, F., et al. is licensed under [CC BY-NC-SA 4.0](#)



## CHAPTER 6: INTRODUCTION TO ZERO EMISSIONS VEHICLES

---

### CHAPTER OVERVIEW

In this chapter, we discuss the concept of zero (almost no) emissions (ZEV) vehicles to low emissions vehicles. Often termed as alternative fuel vehicles, these vehicles are hailed as a more sustainable counterpart of traditional gasoline and diesel operated vehicles. The alternatives that would be discussed are battery electric vehicles, hybrid vehicles, fuel cell vehicles, hydrogen vehicles, compressed natural gas vehicles, and liquid petroleum gas vehicles. We will discuss all form factors and vocation types as it pertains to movement of people and goods – from scooters to mass transit, from last and first mile delivery to continental trucking.

#### Chapter Topics

1. [Role of Combustion in Emissions Generation](#)
2. [Zero Emissions Power Generation for Transportation](#)
3. [Electricity and Hydrogen as Zero Carbon Fuels for Transportation](#)
4. [A California Case Study for Zero Emissions Buses](#)
5. [Heavy Duty Vehicle Electrification](#)
6. [California ZEV Market and Incentives Programs](#)

#### Learning Objectives

At the end of the chapter, the reader should be able to do the following:

- Select appropriate ZEV technology to sustainably meet any specific travel needs.
- Evaluate the infrastructure and investment needs for different ZEV technologies.
- Reflect on the current ZEV adoption and prescribe public and private financial mechanisms to promote adoption of these vehicles.

### THE ROLE OF COMBUSTION IN EMISSIONS GENERATION

Combustion is the principal technology that powers the energy economy. Simply stated, combustion is at the heart of our everyday lives, from the provision of electricity to our home and place of work, to the automobiles we drive, to the propulsion of jet aircraft we fly. Combustion is also the principal source of the environmental impact we experience, from climate change to degraded urban



air quality. The following four principal forces are driving the paradigm shifts from our dependency on combustion to alternative technologies for the generation of electricity and powering of vehicles:

1. Degraded urban air quality (1943): The first evidence of persistently degraded urban air quality in the United States was chronicled in the *Los Angeles Times*, describing a **tenacious haze** that seemed to irritate eyes and cause many to cough (Figure 6.1). Today, urban regions throughout the world (for example, in India, China) are affected by degraded air quality.



Figure 6.1: [Los Angeles 1943: Degraded Unraban Air Quality](#) by Ramanathan et al is licensed under [CC BY-NC-SA 4.0](#)

2. Finite petroleum resources (1980s): Automobile companies recognized that petroleum was finite and demand may outweigh discovery in the next millennium.
3. Climate change (1990s): The world recognized that anthropogenic sources may be affecting the climate, leading to the signing of the UN Framework Convention on Climate Change in 1992.
4. Fuel independence (2001): The assault on the World Trade Center enhanced the urgency to reduce US dependence on foreign sources of petroleum.

Depending on the type of engine, either air is compressed to a high pressure and fuel is added, or a fuel-air mixture is compressed to a high pressure. In both cases, the fuel-air mixture is then ignited, initiating a **combustion** process (essentially “burning” the fuel-air mixture) that transforms the energy

bound in the fuel (for example, gasoline) to high-temperature gas (thermal energy). The high-pressure, high-temperature gas then pushes on a piston (to power the transmission in a traditional gasoline vehicle, or generate electricity in a gasoline hybrid vehicle) or expands through a turbine (to generate electricity for the home and business). From this process, depicted in Figure 6.2, you can intuitively deduce that (1) the efficiency (the percentage of energy bound in the fuel that is transformed to useful power) will be limited by the friction associated with all of the mechanical steps, and (2) criteria pollutants will be formed because of combustion chemistry and emitted in the exhaust.

When you consider the role of combustion in everyday life, the examples seem limitless (for example, cooking; heating water; space heating; generating electricity; propelling aircraft and rockets; and powering automobiles, buses, trucks, locomotives, and ships). Simply stated, combustion is interwoven into the fabric of both the quality of life and the economics of the world's markets.

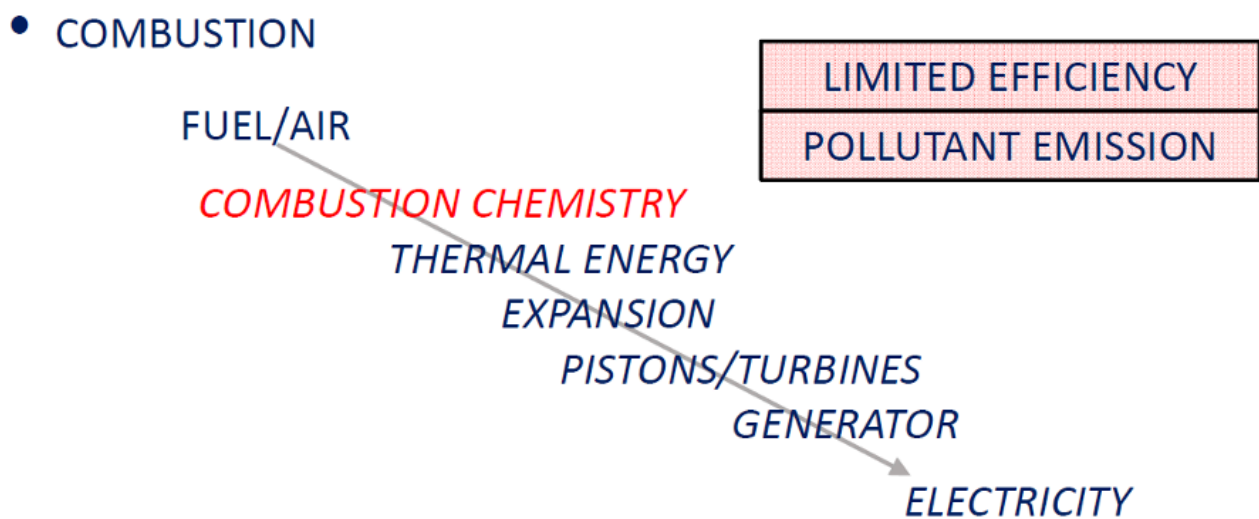

Figure 6.2: [Combustion](#) by Ramanathan is licensed under [CC BY-NC-SA 4.0](#)

In Figure 6.3, the relationship between combustion and the environment is illustrated. Fuel and air are injected into a chamber, ignited to liberate the energy bound in the fuel into thermal energy, and expanded to produce a useful product.

Unfortunately, combustion has an exhaust as a by-product composed of criteria pollutants that degrade urban air quality (affecting the public health) and carbon dioxide (affecting the world's climate). Notably, the amount of criteria pollutant mass in the exhaust is minuscule and was historically ignored until the first consequences to public health in modern times surfaced in 1943 (Los Angeles) and 1952 (London).<sup>1</sup> It is as if Nature incorporated environmental impacts in the combustion of fossil fuels to counsel the world's population that combustion is not sustainable.

Why is it that such a minuscule emission of a few chemical criteria relatively modest emission of CO<sub>2</sub> affects the world's climate? Consider that the atmosphere is evenly distributed in a thin layer around the Earth, barely 10 miles in depth. In Figure 6.3, the purple sphere in the image represents the volume of all the air if it were gathered together, relative to the volume of the Earth. The image conveys the surprisingly small air resource upon which life on Earth depends, and the relatively small volume of air into which products of combustion are injected. Within this small volume, CO<sub>2</sub> and

1. Ramifications of combustion exhaust were observed centuries before, an example of which is "fumifugium" (Evelyn 1661).

other greenhouse gases (GHGs) accrue to affect climate, and secondary criteria pollutants are formed and primary criteria pollutants amass to degrade urban air quality. As noted in Figure 6.3, combustion is responsible for over 90% of the world's emission of CO<sub>2</sub> and criteria pollutants.

In addition to contaminating the air resource with CO<sub>2</sub> and criteria pollutants, the combustion process has an impact not widely recognized: namely the consumption of oxygen from the air. For every tankful of gasoline in your car, a ton of air (2,000 pounds) passes through your engine, and 400 pounds of oxygen are consumed. Given the finite resource of oxygen in the atmosphere, this is sobering. While Nature appears to be replenishing the oxygen removed to date, an increasing demand for oxygen could lead to an additional point of environmental stress. Fortunately, the evolving transition from a classic “combustion-dominant construct” to a “renewable-dominant construct” will, in parallel with reducing the emission of CO<sub>2</sub> and criteria pollutants, serve to mitigate the likelihood of this environmental stress.

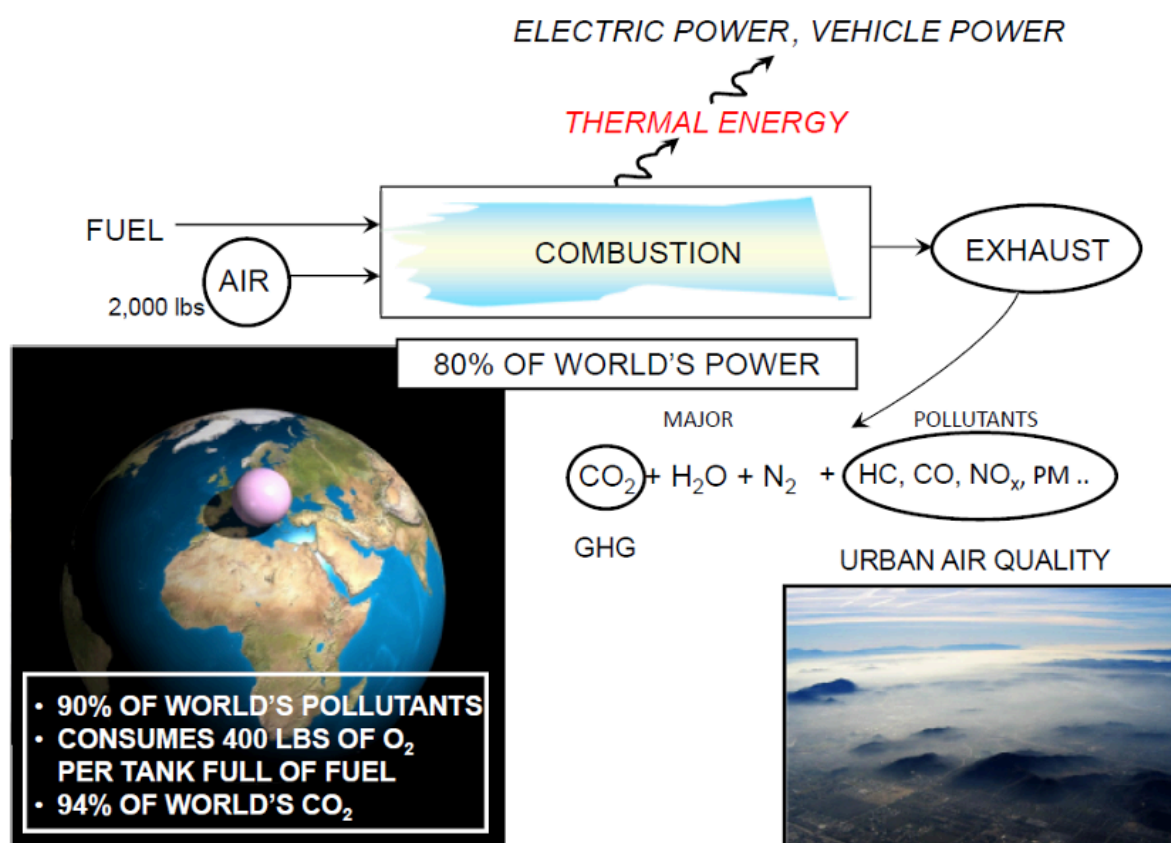

Figure 6.3: *Combustion Impacts* by Ramanathan et al is licensed under [CC BY-NC-SA 4.0](https://creativecommons.org/licenses/by-nc-sa/4.0/)

### An Alternative to Combustion

Because combustion emits carbon dioxide and criteria pollutants as unavoidable by-products, an alternative to combustion that can operate (1) more efficiently than combustion (thereby reducing CO<sub>2</sub> per megawatt hour), (2) with a zero-carbon fuel (thereby emitting no CO<sub>2</sub>), and (3) without the emission of criteria pollutants would be preferred.

An emerging alternative to combustion is **fuel cell technology** (Figure 6.4), which converts fuel and air to electricity in a single step. Intuitively, you can imagine a higher efficiency in the absence

of mechanical friction. You can also imagine virtually zero formation and emission of criteria air pollutants, due to relatively low-temperature and relatively benign electrochemistry. In addition, fuel cells are quiet—a welcomed attribute for deployment as a distributed generator in the midst of where the public resides (homes) and works (industry, office buildings, and hospitals, for example).

- COMBUSTION

FUEL/AIR

COMBUSTION CHEMISTRY

THERMAL ENERGY

EXPANSION

PISTONS/TURBINES

GENERATOR

ELECTRICITY

LIMITED EFFICIENCY
POLLUTANT EMISSION

- FUEL CELL

FUEL/AIR

ELECTROCHEMISTRY

ELECTRICITY

HIGH EFFICIENCY
NO POLLUTANT EMISSION
ACOUSTICALLY BENIGN

Figure 6.4: [Power Generation Options](#) by Ramanathan is licensed under [CC BY-NC-SA 4.0](#)

## ALTERNATIVE FUELS

The Energy Policy Act of 1992 defines an alternative fuel as:

- Biodiesel (B100)
  - Biodiesel is a renewable fuel that can be manufactured from vegetable oils, animal fats, or recycled cooking grease for use in diesel vehicles.
- Natural gas and liquid fuels domestically produced from natural gas
  - Natural gas is a domestically abundant fuel that can have significant cost advantages over gasoline and diesel fuels.
- Propane (liquefied petroleum gas)
- Electricity
- Hydrogen
- Blends of 85% or more of methanol, denatured ethanol, and other alcohols with gasoline or

other fuels

- Ethanol is a widely used renewable fuel made from corn and other plant materials. It is blended with gasoline for use in vehicles.
- Methanol, denatured ethanol, and other alcohols
- Coal-derived, domestically produced liquid fuels
- Fuels (other than alcohol) derived from biological materials
  - Renewable diesel is a biomass-derived transportation fuel suitable for use in diesel engines.
- P-Series fuels

## TRANSITION TO ALTERNATIVE POWER GENERATION FOR TRANSPORTATION

The next generation of vehicles is emerging in response to environmental pressures and a goal of fuel independence. The environmental pressures, which include the mitigation of climate change and air quality degradation, require a dramatic reduction in the emission of GHGs and air pollutants from the transportation sector as well as the electric sector. Fuel independence requires removing reliance on the international sourcing of carbon-rich fossil fuels and the associated geopolitics. In response, vehicles of all sizes are transitioning from combustion engines and mechanical drivetrains to alternative vehicles with battery and fuel cell engines and electric drivetrains. The transition began with light-duty vehicles, expanded into medium-duty vehicles, and is now emerging with heavy-duty vehicles including buses. This transition involves a merging of the transportation system with the electricity generation system.

Alternative vehicles encompass **fuel cell electric vehicles (FCEVs)** and **plug-in electric vehicles (PEVs)**. Examples of PEVs are **battery electric vehicles (BEVs)** and **plug-in fuel cell electric vehicles (PFCEVs)**.

All of these vehicles have a few key characteristics in common. First, alternative vehicles are designed to operate on fuels that portend (1) a potential of zero emission of both GHG and criteria pollutants and (2) an opportunity to be generated locally and thereby achieve the goal of fuel independence. Second, alternative vehicles have no tailpipe emissions of carbon or criteria pollutants. The GHG and criteria pollutant emissions, if any, come solely from the fuel supply chain, such as the generation of electricity or production of hydrogen. Electricity and hydrogen are the two fuels emerging to power alternative vehicles.

### Electricity as a Fuel

For PEVs, the electric grid becomes the source of the fuel. PEVs garner electricity from the home, from the place of work, and in the conduct of business at commercial centers such as big-box stores, shopping centers, and hotels. Referred to as G2V (grid-to-vehicle), extracting energy from the grid adds a new load to the grid. Conversely, PEVs have the potential to provide beneficial attributes to the grid. With what is called V2G (vehicle-to-grid), energy can be extracted from qualified vehicles to serve loads when generating assets are strained.

The existing grid is able to accommodate modest charging events, but as the number of charging events increases (for example, at homes), local transformers may overload and fail. As a result, either upgrades to transformers or controlled charging (that is, smart charging), or both, will be required.

In this process, while the emissions of pollutants from the tailpipes and electric grid are virtually zero and the emission of carbon from the vehicles is zero, the carbon emissions from the electric grid will not be zero with stationary fuel cells (as mentioned above) operating on fossil fuels (for example, natural gas) and biogas. What is required is a zero-carbon fuel.

### **Hydrogen as a zero-carbon fuel**

For FCEVs, hydrogen is the fuel. For PFCEVs, hydrogen is the “longrange” fuel (300 to 400 miles) while electricity is the “short-range” fuel (50 to 150 miles). While the vehicles themselves emit zero carbon, the supply chain of electricity (as noted above) and hydrogen can be major sources of atmospheric carbon if not carefully planned. For example, hydrogen has been traditionally generated in large plants by the steam reformation of natural gas at elevated temperatures. The principal component of natural gas is methane (CH<sub>4</sub>), with concentrations varying around the world from 70% to over 90%. Other components can be other hydrocarbons (for example, propane and ethane) and inert chemicals such as carbon dioxide and nitrogen.

Today, over 50 million metric tons of hydrogen from steam methane reformation (SMR) are produced annually worldwide, and 11 million metric tons are produced in the United States to support manufacturing (for example, of chemicals, foods, and electronics) and the refining of petroleum to generate gasoline. Notably, the amount of hydrogen needed to fuel 20 million FCEVs in California (today’s population of all vehicles in California) is just 20% more than the hydrogen generated today for the production of gasoline in California. If all the vehicles were PFCEVs, less than 80% would be required. However, SMR hydrogen has an associated emission of CO<sub>2</sub>. What is required is the generation of renewable hydrogen without the emission of carbon. An initial step in the production of renewable hydrogen is the generation of carbon-neutral biohydrogen using tri-generation for fueling FCEVs and PFCEVs as well as stationary fuel cells. As noted previously, the vast majority of renewable hydrogen is expected to be sourced from the generation of electrolytic zero-carbon hydrogen from otherwise curtailed solar and wind. Not only can electrolytic zero-carbon hydrogen be stored over long periods of time and used in stationary fuel cells as diurnal or seasonal demand requires, it can also be used to fuel FCEVs and PFCEVs.

To use the California example again, systems analyses show that the amount of renewable zero-carbon hydrogen generated by otherwise curtailed renewable resources will be more than ample to fuel FCEVs. While water is also required, fueling all the state’s 20 million vehicles with electrolytic zero-carbon hydrogen would need less than 1% of the daily water flow in the California Aqueduct. If all vehicles were PFCEVs, less than 0.2% would be required.

For dispensing hydrogen to FCEVs, fueling stations are today being deployed at existing gasoline stations. The locations are already zoned for fueling, and the public is familiar with the location as a fueling site. Hydrogen dispensing can be added to an existing island (displacing a gasoline dispenser) or on a newly established fueling island. Over time, gasoline dispensers could be replaced one by one as hydrogen-fueled vehicles displace gasoline-fueled vehicles.

California, again, provides an illustration of the scale of fueling infrastructure that will be required. Approximately 9,800 gasoline stations serve the California population, with multiple stations often sharing the same intersection. However, hydrogen dispensing will not be required at all of the existing gasoline stations. The reasons include the high efficiency of hydrogen vehicles, meaning they can drive farther before refueling than gasoline-powered cars can, and the replacement of competition from the fuel pricing at intersections (often leading to four gasoline stations at an intersection) to

the smart phone. For example, it is estimated that a minimum of 1,600 hydrogen stations are needed to fuel a full build-out of FCEVs in 2050. While this number of stations gives drivers a maximum 6-minute access to a hydrogen dispenser, the actual number will likely be larger in order to not overcrowd any one station. If PFCEVs alone were deployed (that is, no FCEVs), the minimum number of stations required statewide would be 93. The larger the percentage of PFCEVs in 2050, the fewer the number of stations over and above 1,600.

In 2019, the number of hydrogen stations in California is approximately 50. They are concentrated at population centers targeted for the introduction of FCEVs by the automobile manufacturers, along with key connector stations (for example, between northern and southern California) and destination stations popular with tourists (for example, Santa Barbara, Lake Tahoe, and Napa Valley).

### **Zero Emissions Hydrogen Generation Processes**

The two technologies commercially available to produce hydrogen with a neutral or zero emission of carbon are steam methane reformation (SMR) using biogas (carbonneutral), and electrolysis powered by otherwise curtailed wind (zero-carbon).

#### *Steam Reformation*

Today, most of the hydrogen in the world is generated by SMR as the most cost effective and efficient of all commercial reformation technologies. Efficiencies for centralized natural gas operated SMR plants range from 76 – 81%. SMR operations currently take place mostly on a centralized scale. An example of non-centralized (i.e., “distributed”) hydrogen generation is the SunLine Transit station in Thousand Palms, California. It is likely that more distributed SMR will be introduced into the emerging hydrogen infrastructure since it can take advantage of the existing natural gas infrastructure for wheeling biogas to produce hydrogen on site. Some companies, such as HyRadix, H2Gen, and Ztek, are working on commercializing integrated SMR systems that generate, compress, and dispense hydrogen into vehicles.

#### *Electrolysis*

Electrolysis is a method of generating hydrogen from water using an electric current to split water into its two parts: hydrogen and oxygen. The source of the electricity dictates the cost of the process, estimated to be 58% of the price at the pump in one study. Using renewable solar or wind generated electricity that would be otherwise curtailed to power an electrolyzer is an environmentally friendly method to generate zero-carbon hydrogen. Large-scale solar and wind farms can be used for centralized generation of electrolytic hydrogen that can be injected into natural gas pipelines (in the earlier years) and dedicated hydrogen pipelines (in later years), stored from days to seasons, and eventually used to either power fuel cell vehicles or generate electricity through gas turbines or fuel cells. The installation cost of a hydrogen pipeline is 1/3 that of an electrical transmission line that moves the same amount of energy. Hydrogen pipelines are also safer than overhead transmission lines, require less maintenance, and are aesthetically preferred. Electrolysis using the electrical power grid comes at a higher environmental cost. Some studies show that generating hydrogen from grid electrolysis to fuel automobiles yields a net increase of GHG emissions compared to today’s conventional vehicles. However, more recent studies establish that power-to-gas (P2G) technology, which involves the conversion of electrical power into a gaseous energy carrier, is a promising



prospect for future energy systems. With P2G, hydrogen can be supplied completely from excess renewable energy, which benefits: 1) balancing the electrical grid with high use of variable, unpredictable renewable power, 2) providing high capacity, long term energy storage for seasonal shifting, and 3) creating a hydrogen supply to promote the use of state-of-art fuel cell vehicles across different transportation sectors, including light, medium, and heavyduty. Additionally, P2G has also been shown to be the most cost-effective approach for longterm energy storage.

## THE NEED FOR ZERO EMISSIONS BUSES: A CALIFORNIA CASE

California Transportation Sector Although public transport by urban bus is generally more environmentally efficient than individual passenger cars, conventional buses are still associated with significant local criteria air pollutant<sup>2</sup> and greenhouse gas emissions<sup>3</sup>.

Air pollution associated with criteria pollutants is a significant concern in urban areas such as California's South Coast Air Basin (SCAB) where heavy-duty vehicles and buses are significant contributors to the total emissions of NOx. While progress has been made in reducing criteria air pollutant emissions from light-duty vehicles, medium-duty and heavy-duty vehicles have been more difficult to address due to the diversity of duty cycles and operational needs encompassed by these sectors. Additionally, powertrains in medium-duty and heavy-duty vehicles have typically relied on diesel fuel in order to satisfy their duty cycles, thereby limiting options for emissions reductions. In addition to criteria air pollutant reductions, many regions of the world have initiated proactive programs to reduce CO2 emissions. California, as an example, has an especially ambitious carbon reduction program. In 2016, total greenhouse gas (GHG) emissions for the State of California were almost 430 million metric tons of CO2 equivalents (MMTCO2e), an overall decrease of 13% from a peak in 2004, and a decrease to 2 MMTCO2e below the 1990 level (the State's 2020 mandated GHG target).

The transportation sector remains the most significant source of GHG emissions in the State, accounting for 41% of the inventory. Figure 6.5 shows the GHG emission by sector for 2016, and Figure 6.6 presents trends for the transportation sector from 2000 to 2016. Figure 6.6 also shows that heavy-duty vehicles are the second largest contributor to (GHG) emissions behind automobiles and that emissions from the heavy-duty sector started decreasing after 2007, even as diesel sales increased.

2. Air pollution contributes to a wide variety of adverse health effects. The U.S. Environmental Protection Agency has established national ambient air quality standards (NAAQS) for six of the most common air pollutants— carbon monoxide, lead, ground-level ozone, particulate matter, nitrogen dioxide, and sulfur dioxide.
3. Gases that absorb infrared radiation and trap heat in the atmosphere are called greenhouse gases.



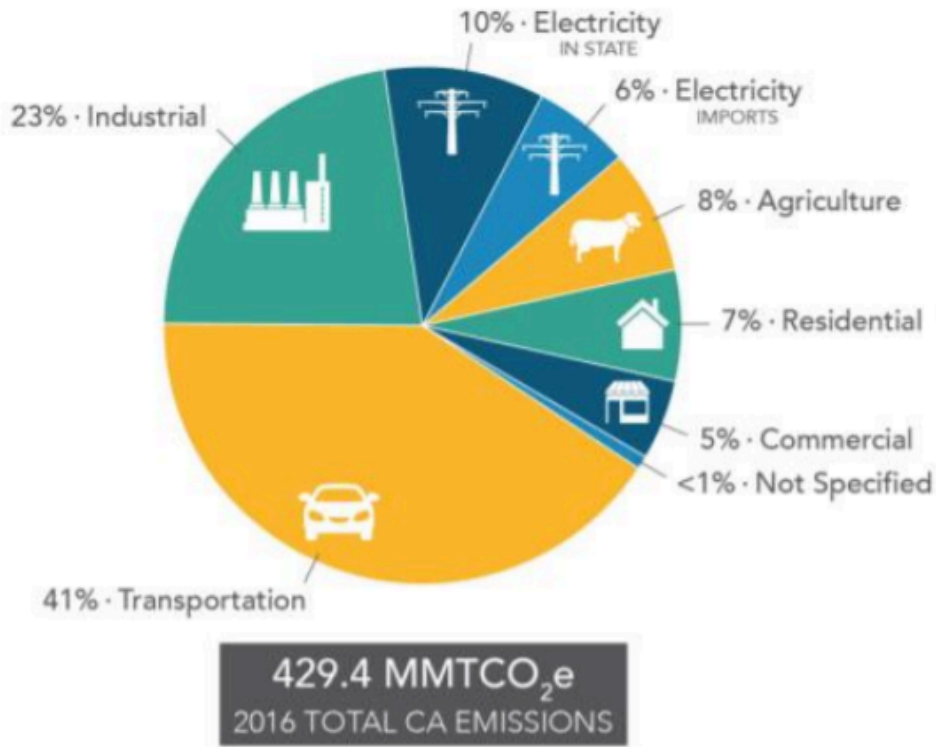

Figure 6.5: [Greenhouse Gas Emissions by Sector for 2016](#) by Anly Castillo is licensed under [CC BY-NC-SA 4.0](#)

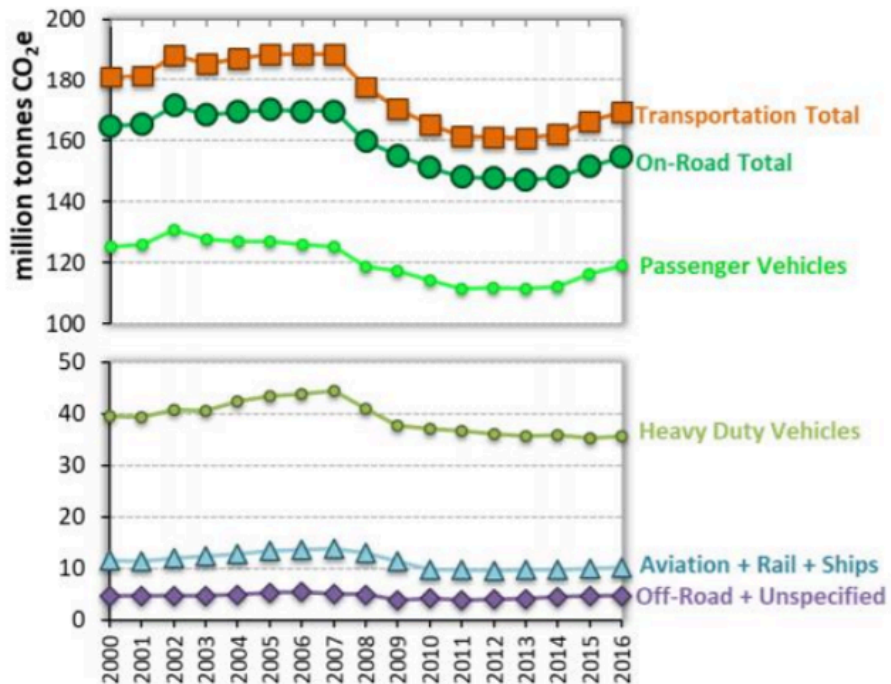

Figure 6.6: [Greenhouse Gas Emissions for the Transportation Sector in California](#) by Anly Castillo is licensed under [CC BY-NC-SA 4.0](#)

## BACKGROUND LEGISLATION FOR URBAN BUSES

In recognition of the need for reduction in greenhouse gas and criteria air pollutant emissions

from urban buses, initiatives to deploy zero emission buses into public transit agencies have been promulgated by governmental authorities around the world. For example, during the 2016 International Zero Emission Bus Conference in London, over 23 cities presented plans to incorporate 60% of ZEBs in their fleet by 2025. This includes initiatives such as the C40 Clean Bus Declaration, which stipulates the acquisition of over forty thousand clean buses by 2040. California has been a leader in pollution and GHG emissions reductions for decades. In 2005 Governor Schwarzenegger enacted Executive order S-3-05 which set into motion three GHG emission goals for the State of California in the near and long-term. These goals are to: 1) bring GHG emissions to 2000 levels by 2010, 2) achieve 1990 levels by 2020, and 3) establish GHG emissions levels by 2050 that are 80% below those recorded in 1990. The first two goals were affirmed by the California Legislature in the passage of Assembly Bill 32 (AB 32) in 2016 (the “Global Warming Solutions Act”). While the third goal has not yet been established as a legal mandate, the Legislature passed SB 32 in 2016, which requires by law a 40% reduction from 1990 levels by 2030.

Other legislation, such as Senate Bill 1078, establishes the Renewable Portfolio Standard (RPS), or renewable energy penetration goals for the state. These goals are delineated in Senate Bill 1078 and are updated by Senate Bill 2 with an aim to have a renewable penetration of 20% by 2013, 25% by 2016 and 33% by 2020. These high penetration objectives, along with future increased load from the electrification of the transportation sector, will have complex and dynamic interactions with the electrical grid. These complex interactions and concurrent complementary technology utilization strategies play a crucial role in energy utilization and price regulation. Therefore, to fully leverage these high renewable penetration rates, a sector-wide, California specific approach must be taken when analyzing the future of California’s energy system and build out of complementary infrastructure.

To meet the schedule and reduction targets, a substantial effort has been focused on the transportation sector to accelerate fleet modernization and increase the penetration of clean engine technologies and cleaner fuels. Part of this effort is the “Innovative Clean Transit” initiative from the California Air Resource Board, with the goal of transforming the statewide transit bus fleet by 2040 through phasing-in ZEB purchases. Related to this effort, several transport authorities have stated commitments to transition to a zeroemissions fleet within the next 15 years. These transit agencies, however, will be tasked with complying with these initiatives while still being able to satisfy the travel patterns of customers in their service area. However, no holistic analysis has been conducted to compare the environmental impacts of the overall fuel supply chain needed for the deployment of ZEBs. This type of analysis is essential to: (1) maximize the emission reduction while minimizing resource consumption in the supply chain (e.g., energy and water), and (2) establish criteria that can identify the most effective combination of ZEB technologies based on the characteristics and limitations of the transit agency. Developing strategies to transition urban bus fleets towards low or zero emissions involves selecting between a wide array of emerging public bus powertrain technologies in the context of operational cycle constraints. However, merely deploying battery electric or fuel cell electric buses do not automatically guarantee significant emissions reductions since many sources of emissions may occur outside of the operating or use phase. Therefore, to gain an accurate assessment of how effective the transition to alternate urban bus powertrain technologies can be, accounting for emissions from the full life cycle of these buses must take place.

## HEAVY DUTY VEHICLE ELECTRIFICATION

Heavy-Duty Vehicles Electrification of the transportation sector has already begun, with more than 1 million light-duty ZEVs on the road in California as of 2021, consisting of 63% BEVs, 36% plug-in hybrid electric vehicles (PHEVs), and 1% FCEVs. While battery-centric drive trains have dominated the LDV sector, battery powered HDVs have more obstacles because of battery size, battery and vehicle/payload weight, vehicle range, and charging times. A number of HDV vocations (e.g., long-haul, public transit) have long distance travel applications, so their electrified powertrains have to accommodate trips with a long range. Other HDV vocations (e.g., drayage) have shorter ranges and are able to operate satisfactorily with battery power.

Charging infrastructure presents an additional challenge in the heavy-duty space for two main reasons. The first is that charging a high-capacity battery takes much longer than fueling a diesel truck. Some vocations only have one shift a day so can charge overnight, but the rest either must take longer stops for charging or companies must develop a robust cache of battery banks charged at warehouses. The second charging infrastructure challenge is the availability of high-power chargers at the correct times of day. Current public vehicle charging infrastructure includes Level 2 AC chargers and DC fast chargers. While Level 2 chargers can be used for overnight charging of light-, medium-, and some heavy-duty vehicles, they are insufficient to charge the largest HDVs and therefore not a comprehensive option. DC fast chargers can charge light- and medium-duty vehicles quickly, or some HDVs overnight but are not able to charge class 7-8 HDVs in short times. Ultimately, in order to build a sustainable zero-emission HDV future that includes BEVs, an investment in higher power, shorter charge time charging infrastructure around the country is required. Alternative fuels, more specifically FCEVs utilizing hydrogen fuel, also present a sizeefficient solution. They have emerged as a feasible option because hydrogen has a higher gravimetric energy density than gasoline, so it can be compressed and stored on board without imposing as much extra weight as a battery on an already heavyweight system. FCEVs also have comparable fueling times and ranges to internal combustion engine vehicles, making them more competitive than BEVs on that metric in the heavy-duty space. Implementation of FCEVs creates vehicle hydrogen demand (VHD) that motivates hydrogen infrastructure development, allowing for further development of a multi-end use hydrogen economy. Specifically, hydrogen converted to electricity by fuel cells for the electric grid, or electricity hydrogen demand (EHD), is a key part of the diversification of economy-wide uses of hydrogen. However, FCEVs come with their own challenges. Like BEVs with charging infrastructure, hydrogen fueling infrastructure is a large barrier to FCEV penetration. According to the California Fuel Cell Partnership, 8 hydrogen stations in California are dedicated to heavyduty refueling and over 50 additional open and online retail stations. Compared to an estimated more than 10,000 diesel and gasoline stations in the state, that is very early infrastructure for a mode of transportation and severely limits the expansion of FCEV technology at all payloads. In order for FCEVs to be truly zero-emission, the hydrogen production infrastructure must also evolve. As of June 2021, 95% of global hydrogen was gray hydrogen, or hydrogen produced from fossil fuels without the use of any carbon capture and storage (CCS) technology. Gray hydrogen compromises the idea of life cycle zero-carbon transportation, so a transition including FCEVs requires investment in carbon-neutral green hydrogen production methods. Those methods include electrolytic hydrogen using electricity from renewable resources, biogas reformation, and artificial photosynthesis. Once a ZEV fleet mix develops, the shift to electrification will have a notable effect on the grid. BEVs and FCEVs both increase grid demand profiles because BEVs draw power directly from the grid and green hydrogen

production for FCEV fueling draws power from the grid for electrolysis albeit utilizing to some extent excess renewable resources.

Electrification will increase peak demand, which is a good indicator of system cost because it defines the maximum capacity at which the grid must be able to comfortably operate [35]. Even though generation does not have to constantly meet peak demand, the transmission system must be able to accommodate it to prevent outages. Fortunately, BEV charging and electrolysis for hydrogen fuel can be considered flexible loads. BEV charging time and rate can be adjusted by the customer manually or smart charging systems can optimize when a network of BEVs charge to minimize cost and strain on the grid. Hydrogen production is even more flexible because the timing of production is not tied to the timing of vehicle fueling; fuel is produced ahead of time, transported to the fueling station, then extracted according to customer needs. Ultimately, the capacity of the electric grid must increase as demand naturally increases over time in addition to the vehicle electrification load. With continued expansion and investment in renewable generation sources, compatible energy storage, and load shifting strategies, peak load can be met and rapid daily ramping managed.

## STATE OF THE CALIFORNIA ZEV MARKET

California's Zero Emissions Vehicle (ZEV) market continues to build momentum. In a span of ten years, the market has grown exponentially from a minimal number of total ZEVs in 2009 to over half 600,000 light-duty ZEVs on the roads in California in mid-2019.<sup>4</sup> ZEVs accounted for nearly eight percent of new light-duty vehicle sales in 2018, which represents a growth in market share of almost 40 percent compared to 2017. Additionally, there are 47 zero-emission light-duty cars and trucks offered for sale or lease in California with more planned in the coming years. While the majority of the ZEVs sold have been Plug-in Hybrid Electric Vehicle (PHEVs) and Battery Electric Vehicle (BEVs), the younger light-duty fuel cell electric vehicle (FCEV) market is gaining momentum growing from fewer than 100 a decade ago to approximately 6,000 on California's roads by mid-2019. The heavy-duty ZEV market is also growing rapidly as ZEV technology transfers from light-duty and smaller heavy-duty ZEV applications, with over 100 models commercially available today and many major manufacturers announcing plans for future commercialization of battery-electric and hydrogen fuel cell electric trucks and buses.

Refueling infrastructure is needed to power the vehicles and support the ZEV market. As of December 2019, California has 22,233 electric vehicle charging outlets, including 3,355 direct current fast chargers (DCFCs), at over 5,674 public stations throughout the State and 41 public retail hydrogen stations located in the major metropolitan areas compared to virtually none a decade ago. The State's goal is to have 1.5 million ZEVs on the road, 250,000 charging outlets, including 10,000 DCFC, and 200 hydrogen stations by 2025 as well as 5 million ZEVs by 2030. The magnitude and speed of effort needed to achieve these goals is unprecedented.

## HISTORICAL ALTERNATIVE FUELS AND VEHICLES INCENTIVE PROGRAMS IN CALIFORNIA

### **Air Quality Improvement Program (AQIP)**

The Air Quality Improvement Program (AQIP), established by the California Alternative and

4. Veloz, 2019. "Sales Dashboard." Last updated: August 6, 2019. <https://www.veloz.org/sales-dashboard/>. Accessed August 15, 2019.

Renewable Fuel, Vehicle Technology, Clean Air, and Carbon Reduction Act of 2007 (Assembly Bill (AB) 118, Statutes of 2007, Chapter 750), was a voluntary incentive program administered by CARB to fund clean vehicle and equipment projects, research on biofuels production and the air quality impacts of alternative fuels, and workforce training. The AQIP [Guidelines](#) and annual [funding plans](#) guided CARB's implementation of the AQIP.

- Hybrid Truck and Bus Voucher Program
  - AQIP background, working group information and regulatory text ([available by request](#))
  - [Program administrator page with list of eligible vehicles / application forms](#)
- Zero-Emission Vehicle and Plug-In Hybrid Light-Duty Vehicle Rebate Project
  - AQIP background, working group information and regulatory text ([available by request](#))
  - [Program administrator page with list of eligible vehicles / application forms \(Clean Vehicle Rebate Project\)](#)

#### **Carpool / HOV Lane Access**

California law allows [single-occupant use of High Occupancy Vehicle \(HOVs\) lanes](#) by certain qualifying clean alternative fuel vehicles. Use of these lanes with a single occupant requires a Clean Air Vehicle Sticker issued by the [California Department of Motor Vehicles](#) (DMV).

#### **Alternative Fuel Incentive Program (AFIP) 2007-2009**

The Alternative Fuel Incentive Program (AFIP), established by Assembly Bill (AB) 1811, required CARB to develop a joint plan with the California Energy Commission to spend \$25 million for the purposes of incentivizing the use and production of alternative fuels. This program has ended.

#### **ZIP I, ZIP II and Fleet ZIP 2001-2004**

The Zero Emission Vehicle Incentive Programs (ZIP I, ZIP II and Fleet ZIP) were administered by CARB in conjunction with the State Energy Resources Conservation and Development Commission (California Energy Commission or CEC).

#### **Lawn and Garden Equipment Replacement Project**

The purpose of the Air Quality Improvement Program (AQIP) Lawn and Garden Equipment Replacement (LGER) Project was to encourage further development and deployment of cordless zero-emission lawn and garden equipment. The availability of incentive funding helped bring a variety of residential and commercial cordless zero-emission equipment to the market.

#### **Zero-Emission All-Terrain Agricultural Work Vehicle Rebate Project**

The \$1.1 million Zero-Emission Agricultural UTV Rebate Project accelerated the use of zero-emission work vehicles for use in California agricultural operations, by providing rebates for the purchase of new, eligible all terrain and utility vehicles on a first come, first serve basis.

## Key Takeaways

- Battery Electric Vehicles (BEVs) are sufficient and, with advances in battery technology, the energy density will dramatically increase, the charging time will dramatically decrease, and the weight will dramatically decrease to provide the range, fueling time, and size provided historically by petroleum-fueled internal combustion vehicles.
- While BEVs have a role, FCEVs and PFCEVs are needed to provide the range and refueling time to which the public is accustomed with conventional gasoline and diesel internal combustion vehicles.
- Fuel Cell technology is also suitable for medium-duty vehicles (such as delivery trucks) and for heavy-duty vehicles (that is, buses and large trucks) where BEV technology is limited or insufficient. FC technology is applicable as well for off-road construction vehicles, locomotives, and ships.

## Self-Test



An interactive H5P element has been excluded from this version of the text. You can view it online here: <https://uta.pressbooks.pub/sustainablemobility/?p=247#h5p-6>

## GLOSSARY: KEY TERMS

**Battery electric vehicles (BEVs):** All-electric vehicles, also called battery electric vehicles, have a battery that is charged by plugging the vehicle in to charging equipment. These vehicles always operate in all-electric mode and have typical driving ranges from 150 to 400 miles.

**Fuel cell technology:** A fuel cell uses the chemical energy of hydrogen or other fuels to cleanly and efficiently produce electricity

**Fuel cell electric vehicles (FCEVs):** FCEVs use a propulsion system similar to that of electric vehicles, where energy stored as hydrogen is converted to electricity by the fuel cell.

**Plug-in electric vehicles (PEVs):** A plug-in electric vehicle (PEV) is any road vehicle that can utilize an external source of electricity (such as a wall socket that connects to the power grid) to store electrical energy within its onboard rechargeable battery packs, to power an electric motor, and help propelling the wheels.

**Plug-in fuel cell electric vehicles (PFCEVs):** Plug-in fuel cell electric vehicles (PFCEVs) combine features of battery electric vehicles (BEVs) and fuel cell electric vehicles (FCEVs). This vehicles are a type of plug-in hybrid electric vehicle where instead of an internal combustion engine a hydrogen generating fuel-cell is used.

## MEDIA ATTRIBUTIONS

- Figure 6.1: [Los Angeles 1943: Degraded Unraban Air Quality](#) by Ramanathan et al is licensed under [CC BY-NC-SA 4.0](#)
- Figure 6.2: [Combustion](#) by Ramanathan is licensed under [CC BY-NC-SA 4.0](#)
- Figure 6.3: [Combustion Impacts](#) by Ramanathan et al is licensed under [CC BY-NC-SA 4.0](#)
- Figure 6.4: [Power Generation Options](#) by Ramanathan is licensed under [CC BY-NC-SA 4.0](#)
- Figure 6.5: [Greenhouse Gas Emissions by Sector for 2016](#) by Analy Castillo is licensed under [CC BY-NC-SA 4.0](#)
- Figure 6.6: [Greenhouse Gas Emissions for the Transportation Sector in California](#) by Analy Casillo is licensed under [CC BY-NC-SA 4.0](#)

## REFERENCES

- Ramanathan, V., Aines, R., Auffhammer, M., Barth, M., Cole, J., Forman, F., et al. (2019). *Bending the Curve: Climate Change Solutions*. Location: Regents of the University of California. Editor: V. Ramanathan. Co-Editors: Adam Millard-Ball; Michelle Niemann; Scott Friese. Book published by the Regents of the Univ of California. Retrieved from <https://escholarship.org/uc/item/6kr8p5rq>. 815pp.under [\(CC BY-NC-SA 4.0\)](#)

## ATTRIBUTIONS

- [Bending the Curve: Climate Change Solutions](#) by Ramanathan, V., Aines, R., Auffhammer, M., Barth, M., Cole, J., Forman, F., et al. is licensed under [CC BY-NC-SA 4.0](#)
- [Technology Mix Optimization for Zero-Emission Fleets Adopting a Multi-Criteria Decision Analysis within a Life Cycle Assessment Framework](#) by Castillo, Analy is licensed under [CC BY-NC-SA 4.0](#)
- [Viable Pathways in the Energy Sector to Meet California Climate Goals with an Emphasis on Heavy-Duty Transportation and Refinery Emissions](#) by Houck, Margaret is licensed under [CC BY-NC-SA 4.0](#)

## CHAPTER 7: DESIGN OF CHARGING INFRASTRUCTURE

---

### CHAPTER OVERVIEW

In this chapter, we narrow down our focus on the infrastructure and investment needs for electric transportation. We will discuss the charging infrastructure planning, design, and operations process; specifically, where the chargers would be placed, how those are used, and who will be using these chargers. We will cover both light-duty and heavy-duty electrification needs. In addition to conductive charging, we will discuss the inductive charging process and discuss the design of wireless charging facilities.

#### Chapter Topics

1. [Charging Methods in EVs](#)
2. [AC and DC Charging in EVs](#)
3. [The Need for Charging Infrastructure](#)
4. [Charging Station Location](#)
5. [Smart Charging and ICT Aspects of Electric Charging](#)

#### Learning Objectives

At the end of the chapter, the reader should be able to do the following:

- Classify the charging infrastructure based on power requirement, vehicle type compatibility, flexibility, and systems resilience.
- Locate chargers based on the ways the chargers are used and the people using the chargers.
- Estimate the equity and environmental justice implications for a given charging infrastructure scenario.
- Summarize the policy pathways to integrate charging infrastructure at the federal, state, and local levels.
- Analyze and design transportation and charging infrastructure in alignment with expanding electrification needs

### CHARGING TECHNOLOGIES FOR EV

Fast, reliable and safe charging possibilities are required in order to help the roll-out of electric mobility. This problem can be considered as a ‘chicken and egg’ problem. Drivers will not consider the electric mobility reliable and comfortable unless there are charging facilities in predictable ranges.



In contrast, the investors of the charging infrastructure would expect quick and regular income after the installation, but it will be probably a mid-term process. It should be noted that this trend can be considered similar to the relationship between the roll-out of the gasoline cars and the petrol stations almost a century ago. When the vehicles in the fleet do not have enough energy left in the battery or if the range is not sufficient to cover a journey, the vehicles are quickly charged to complete the trip. On the other hand, the vehicles can be charged at a low power when they are parked overnight. Besides this, swapping of batteries can provide a unique opportunity to get a full battery pack in minutes, similar to the short fueling times of gasoline cars.

And now, let's dive straight into the content. You will learn about various EV battery charging methods like AC charging, DC charging, wireless inductive charging, and battery swap. The module will conclude with smart charging and **Vehicle-to-Grid (V2G)** and an introduction to ICT aspects of EV charging. Hope you have a successful learning experience!

## CHARGING METHODS IN EVS

There are different ways to charge the EV battery. In all these methods power from the conventional AC grid is directly or indirectly converted from AC to DC to charge the EV battery. In the Introduction course, we looked at AC and DC charging of EV. Besides this, EVs can be charged by wireless inductive charging and by battery swap technology. Watch this lecture by Pavol Bauer to get an overview of the various EV charging methods!



One or more interactive elements has been excluded from this version of the text. You can view them online here: <https://uta.pressbooks.pub/sustainablemobility/?p=311#oembed-1>

As explained in the lecture, the three common ways to charge an EV are:

1. Conductive charging – AC and DC
2. Inductive charging – Static and Dynamic
3. Battery swap technology

The physical location of the components for converting the power supplied by the grid to that required by vehicle battery can be categorized as onboard and offboard chargers. Onboard chargers are located within the vehicle, and the size and power rating are constrained by the available space within the vehicle. Off-board chargers are located outside the vehicle, and this setup provides more flexibility in terms of the power that can be delivered. Both classes of charging devices must contain control circuits and communicate in real-time with the vehicle battery. This is to ensure that the battery is charged in an optimum way, avoiding any damage to the battery through overcharging. AC charging uses an onboard charger while DC and battery swap use an off-board charger. In case of an inductive charger, a combination of both an onboard and off-board charger are required.

### Conductive Charging

This is the most common charging method right now and it has 2 categories: AC and DC charging.

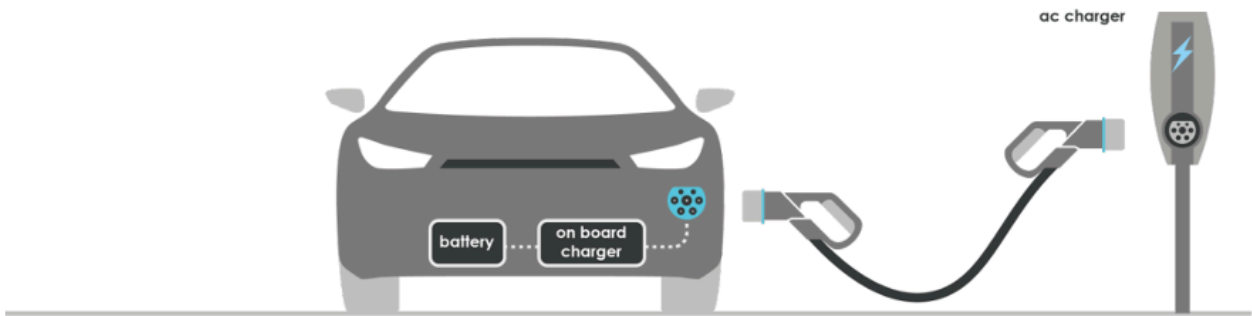

Figure 7.1: [Conductive Charging- AC by Electric Cars: Technology](#) is licensed under [CC BY-NC-SA 4.0](#)

The advantages of this method are:

1. The battery can be recharged anywhere using the AC grid and the onboard EV charger.
2. The EV charger can easily communicate with the Battery Management System (BMS) and no additional power electronic converters are needed in the EV charger. This leads to a higher performance and lower cost.

And the disadvantages are:

1. AC power has to be converted into DC power in the car, and there is a limitation of the power output for AC charging due to size and weight restrictions of the onboard charger.
2. AC charging needs relatively long time due to the relatively lower charging power.

DC charging is suitable for high power EV charging, and the power output of fast charges is limited only by the ability of the batteries to accept the charging power.

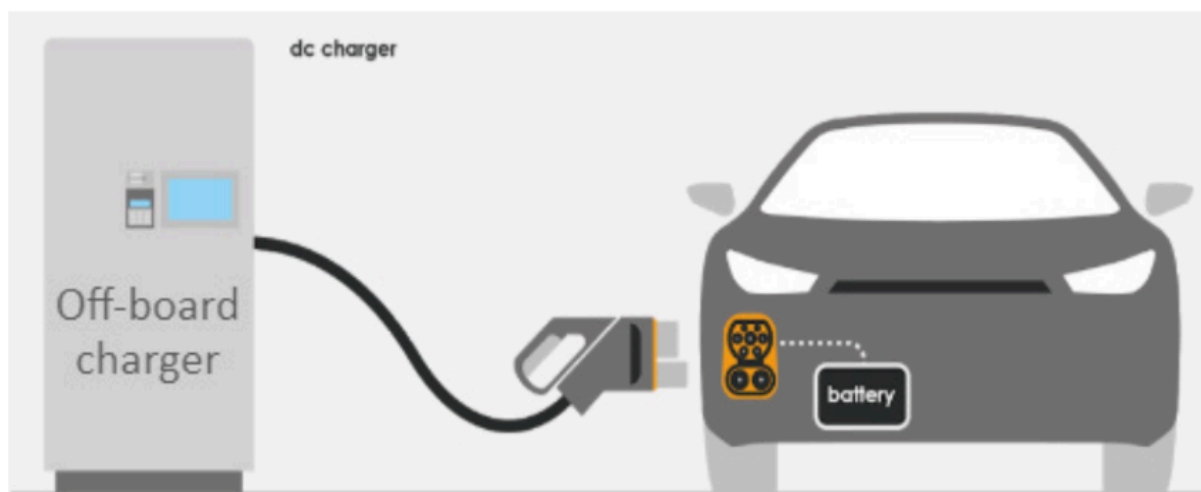

Figure 7.2: [Conductive Charging- DC by Electric Cars: Technology](#) is licensed under [CC BY-NC-SA 4.0](#)

The advantages of this method are:

1. It can be designed with either a high or low charging rate, and is not limited in its weight and size.
2. DC charging with high power requires low charging time.

And the disadvantages are:

1. Higher investment for installation of the charger when compared to AC charging.
2. Adverse impact on power system: high power demand on the grid esp. at peak hours.
3. Since the off-board chargers and the BMS are physically separated, reliable communication is important to ensure correct charging conditions.

### **Inductive Charging**

The main idea behind inductive charging is the use of two electromagnetically linked coils. The primary coil is placed on the road surface, in a pad-like construction linked to the electricity network. The secondary coil is placed on the vehicle, ideally on the bottom or top of the car. The 50Hz AC power from the grid is rectified to DC and is then converted to a high-frequency AC power within the offboard charger station. Then this high-frequency power is transferred to the EV side by electromagnetic induction. The coils on the car convert this high-frequency AC power back to DC to charge the EV using the onboard charger.

The advantages of this method are:

1. Convenience
2. Suitable for self-driving cars

And the disadvantages are:

1. High investment
2. Limited space & weight of charge pads
3. Misalignment tolerance between the vehicle and the charge pad
4. Power losses and relatively lower efficiency than conductive charging
5. Electromagnetic radiation exposure

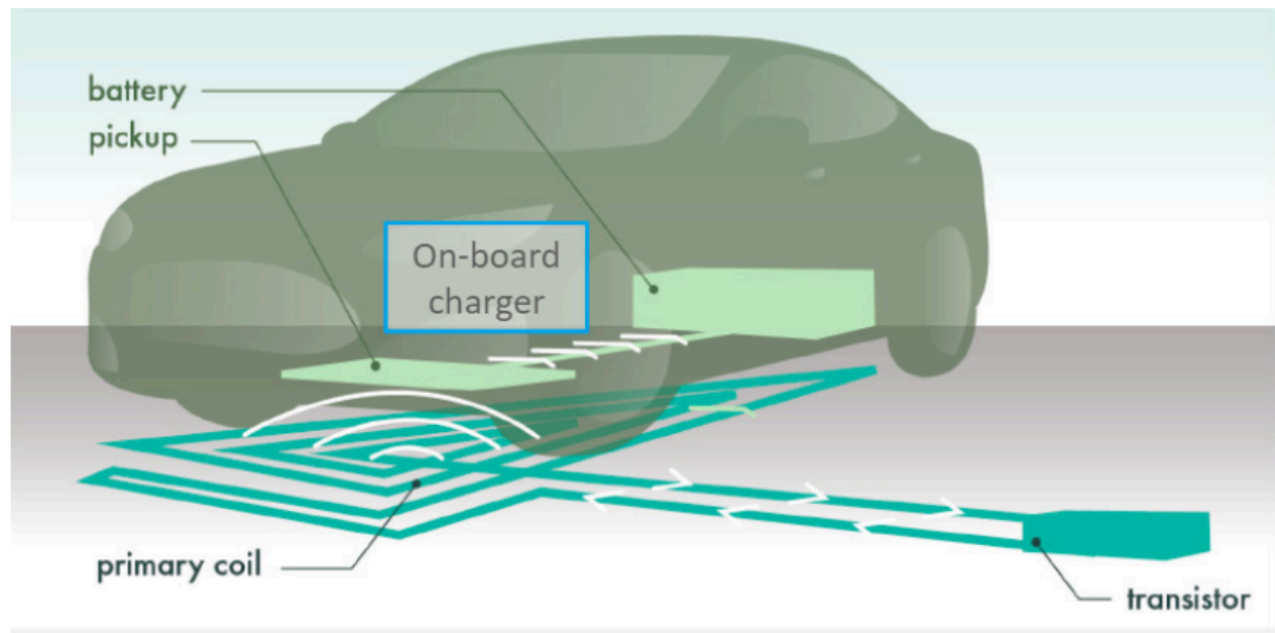

Figure 7.3: [Inductive Charging- Static by Electric Cars: Technology](#) is licensed under [CC BY-NC-SA 4.0](#)

The other way to charge a car wirelessly is called dynamic charging. The coils connected to electric cables which used to provide the power are buried in the road. The coils emit an electromagnetic field that is picked up by vehicles driving over them and converted into electricity to charge the cars.

Advantages:

1. Low stand-in charging time
2. Low battery DoD
3. Smaller battery size

So far the dynamic inductive charging is still in the experimental stage because there are many challenges to standardize it. The challenges are:

1. The high cost of investment
2. Foreign objects, coil structure changes and coil misalignment on the road
3. Applicability of different car types and universal coil type selection

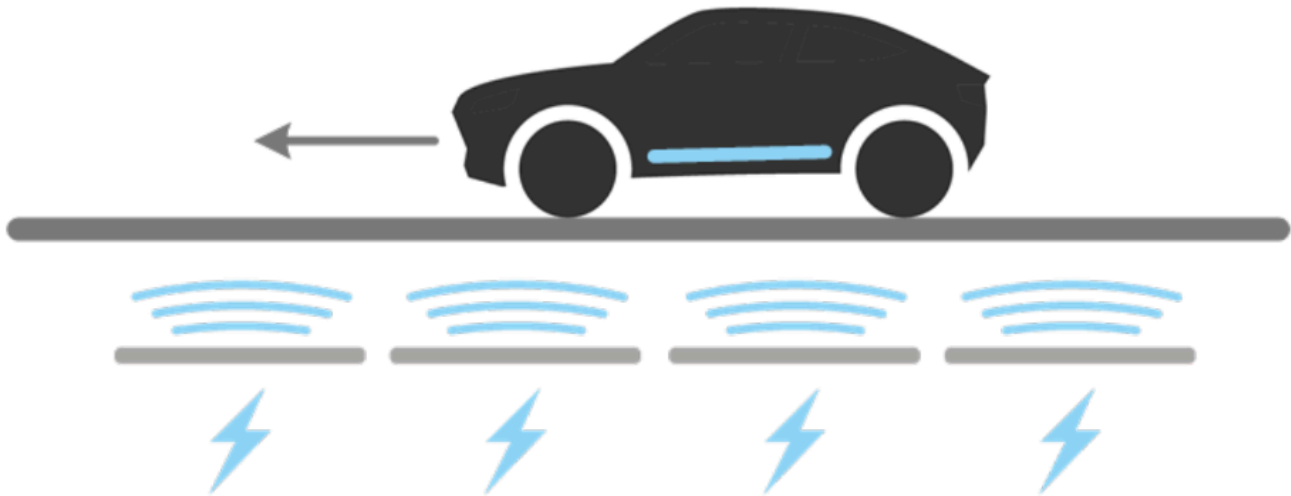

Figure 7.4: [Inductive Charging- Dynamic by Electric Cars: Technology](#) is licensed under [CC BY-NC-SA 4.0](#)

### Battery Swap

The third method of EV charging is battery swap. It works on the basis of switching out the depleted battery and replacing the same with a full battery. The process involves driving into a battery switching bay and an automated process will position the vehicle, switch out the current battery and replace it with a fully charged battery. The depleted batteries are charged in the station for later deployment. The system works on the business concept that the EV user owns the vehicle and not the battery. Battery swap requires a foolproof way to estimate the batteries state of health to check for its usage pattern and to ensure that only authorized vehicles and charging stations can charge it.

The advantages of this method are:

1. No **range anxiety**
2. Quick and easy refilling like a combustion engine car tank
3. Longer charging times available for the EV battery compared to fast DC Charging

The main challenges to this method are:

1. The requirement of standardized battery interface across multiple car manufacturers.
2. Consumer acceptance of not owning a battery and having to change the vehicle battery.

## Comparison of EV Charging Methods

Battery powering methods	Conductive charge		Inductive charge		Battery swap
	AC	DC	Static	Dynamic	
Convenience	☺	☺	☺☺	☺☺☺	☺☺
Cost	€	€€	€€ ~ €€€	€€€€€€	€
Service time	Relatively long	Very short	Relatively long	Very flexible	Shortest
Power level	⚡⚡	⚡⚡⚡⚡	⚡ ~ ⚡⚡	⚡⚡ ~ ⚡⚡⚡	⚡ ~ ⚡⚡⚡
Efficiency	🔌🔌🔌🔌	🔌🔌🔌	🔌🔌	🔌	🔌🔌🔌🔌
Battery lifetime	() () ()	() ()	() () ()	() () () () ()	()
Impact on grid	■ ~ ■■	■■■■	■■	■■ ~ ■■■	■■■
Standardization challenge	ⓘ	ⓘ	ⓘ ⓘ	ⓘ ⓘ ⓘ ⓘ	ⓘ ⓘ ⓘ

Table 7.1 is licensed under [CC BY-NC-SA 4.0](https://creativecommons.org/licenses/by-nc-sa/4.0/)

Let's have an overall comparison of all these battery powering methods. From this table, we can see the overall comparison of all battery powering methods.

- It can be observed that the dynamic inductive charging is the most convenient charging method but also the most expensive. Even if the static inductive is cheaper compared to the dynamic one, the average cost of inductive charging is higher than any other method. Dynamic inductive charging has the most flexibility as the car can be charged at any time when on the way and do not need to stop by the service point.
- To power the battery, the battery swap method needs the shortest serving time. For all charging methods except battery swap, the serving time is highly related to the power level. In this case, the DC conductive charging method has the highest power capacity among all the methods.
- There are many factors that impact the efficiency, e.g. the number of power converters and their types, the charging power, and the charging methods. From the table, we can see that, in general, the conductive charging method has higher overall efficiency than inductive charging. It is because the power conversion process using an air gap is less efficient than direct power transfer using cables. Further, the efficiency of inductive charging reduces as a result of the misalignment between the sending and receiving charge pads.
- The battery lifetime is depending on many factors, for example, the charging power (C-rate) and the DOD. The battery lifetime in DC charging has the lowest lifetime because the charging power and hence the corresponding C-rate are the highest. Further, typically at fast charging stations, people want to charge their batteries as much as possible for long distance trips increasing the depth of discharge as well. In contrary, batteries operated with dynamic

inductive charging method has the longest lifetime expectations because the batteries can be charged/discharged with small DOD.

- From the perspective of grid impact, the DC charging method has the most significant impact since it has the highest power level. Besides, the battery swap could also have a high impact on the grid if the charging powers are high as well.
- Finally, considering standardization challenge, the dynamic inductive charging and the battery swap are faced with the most difficult challenges. It is because both methods require standardization between car types, battery size, power level and even shape.

## AC CHARGING OF EVS

AC charging using the onboard charger of an EV is the most popular and simplest means of charging an EV today. Large power plants produce alternating current (AC) power which is transmitted over long distance transmission lines to our homes. Most of our homes get AC power supply from the grid and a large number of the appliances we use in our homes also run on AC power. The EV battery as we learnt earlier requires direct current (DC) power. The question that arises is how do we charge electric vehicles with AC power from the grid? Is AC charging of EVs done the same way all over the world? If not, what are the differences? And finally, the question which is most important for an EV user: how long does it take to charge your EV with AC power? Find out the answers to those questions in this lecture by Gautham Ram Chandra Mouli on AC charging of EVs.



One or more interactive elements has been excluded from this version of the text. You can view them online here: <https://uta.pressbooks.pub/sustainablemobility/?p=311#oembed-2>

AC charging allows EVs to be charged by using inexpensive AC charging stations which feed AC power directly from the grid to the car. The nature of AC, that is, single phase or three phase, voltage level and grid frequency may vary from country to country. AC charging uses an onboard charger to convert AC power from the conventional AC grid to direct current or DC power to charge the traction battery. Cars have a standardised vehicle inlet, and a charging cable is used for connecting the vehicle connector to the infrastructure socket of the AC charging station. The onboard charger needs to be light (typically less than 5 kg) and compact due to the limitation of allowable payload and space in the EV and the PHEV. The drawback of this charger is the limitation of the power output because of size and weight restrictions.

### AC Charger Operations

When the charging station and the EV are first connected, the charge controller in the station communicates with the EV. Information regarding the connectivity, fault condition and current limits are exchanged between the charger and the EV.

- When the AC power is provided to the EV, the onboard charger has a rectifier that converts the AC power to DC power. Then, the power control unit appropriately adjusts the voltage

and current of a DC/DC converter to control the charging power delivered to the battery.

- The power control unit, in turn, gets inputs from the Battery Management System or the BMS for controlling the battery charging.
- Apart from this, there is a protection circuit inside the onboard charger. The BMS triggers the protection circuits if the battery operating limits are exceeded, isolating the battery if needed.

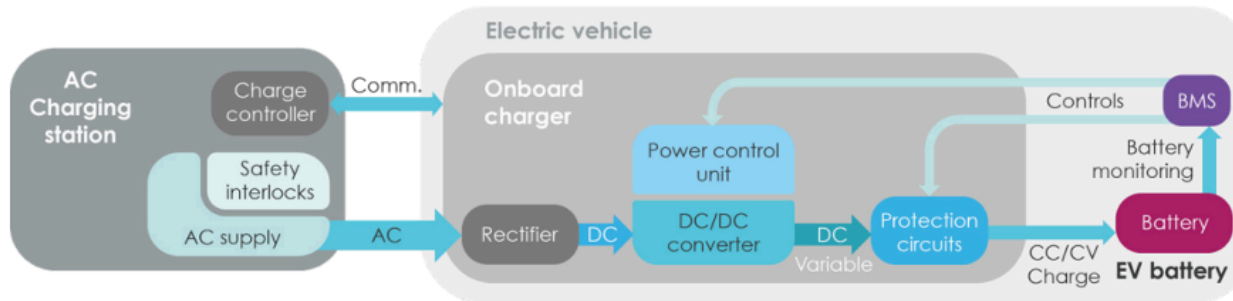

Figure 7.5: [AC Charging Operations by Electric Cars: Technology](#) is licensed under [CC BY-NC-SA 4.0](#)

## AC CHARGING -TYPES

The EV industry has not agreed on one specific AC connector, so depending on the car brand and country, the connector varies in shape, size and pin configuration. One of the main reasons is the difference in AC voltage and frequency. Generally, an AC connector has two or more larger pins to transmit power, and some smaller pins for communication. Four types of AC connectors are used worldwide, namely:

- The Type 1 connector, which is mostly used in USA & Japan.
- The Type 2 connector, which is mostly used in Europe, including those of Tesla cars.
- The Type 3 connector, used in Europe but is being increasingly phased out by Type 2 connectors.
- The proprietary connector used by Tesla for its cars in the USA.
- China has its own standard for AC charging, which is similar to Type 2 connectors.

## DC CHARGING OF EVS

Range anxiety is the fear that the electric vehicle does not have enough capacity to travel anywhere that is far away. This means no EV road trips, no leisurely drives through the mountains, potentially even no cross-city travel. Yes, EV range is continuing to grow, but it is nowhere near the range of its gas-powered equivalent and the charging times are still relatively longer.

Mitigating this issue is DC fast-charging. They can charge many electric cars to 80-percent capacity in around 30 minutes, though charging rate slows down significantly after that to avoid damaging the battery pack. The tradeoff is that DC fast-charging stations are more expensive to install and operate. Large scale adoption of electric cars is possible with higher charging powers and more fast-charging



stations. This allows the car makers to use smaller battery packs, thus reducing the cost of an EV's most expensive component. Hence, could be a possible solution for the range anxiety.

We know that fast charging is quite attractive in the sense of high power charging with short charging times. But how does a DC fast charger work? What are the different DC charging systems around the world? Gautham Ram Chandra Mouli will be answering these question for you in this lecture. Find out now!



One or more interactive elements has been excluded from this version of the text. You can view them online here: <https://uta.pressbooks.pub/sustainablemobility/?p=311#oembed-3>

## THE NEED FOR CHARGING INFRASTRUCTURE

The usage of electric vehicles (EVs) has steadily increased over the past decade (Burnham et al., 2017) with the total number of EVs on the road in the United States (US) surpassing 1.3 million as of October 2019 (Edison Electric Institute, 2019). Despite the recent growth in the EV market, EVs still represent a small proportion of light-duty vehicles in the US and across the world, with conventional gasoline-powered vehicles (GVs) representing the largest proportion. Given EVs (i) produce zero tailpipe emissions while GVs produce a variety and high-volume of harmful local pollutant emissions and (ii) EVs can be powered by renewable energy sources with minimal greenhouse gas emissions while GVs can only utilize greenhouse gas emitting fuel, the potential social and environmental benefits of converting the light-duty vehicle fleet from predominantly GV to predominantly EV are significant.

One of the main factors limiting the growth of EVs is the limited public and commercial EV charging infrastructure throughout the US and the world. A specific shortcoming of existing EV charging infrastructure is the lack of 'fast' chargers, also known as Level 3 chargers. CHAdeMO (2020) suggests a strong positive correlation between the number of fast chargers installed in cities in Japan and the number of EVs sold in those cities, indicating an important connection between EV growth and fast-charging infrastructure. Level 3 chargers are 8 to 12 times more efficient than Level 2 'slow' chargers. While Level 1 and Level 2 chargers are often used for at-home or at-destination (e.g., the workplace or shopping center) charging, Level 3 fast-charging enables en-route (or mid-trip) charging. Moreover, Level 3 charging is preferable for quick charging, long distance travel, and emergency charging, where charging time is a critical concern (Jabeen et al., 2013). Fast-charging services are also beneficial for households living in high-density residential buildings where home charging may not be available. The dearth of fast-charging facilities in the US is compounded by the shorter driving distances and longer recharging times of EVs compared to. In fact, 'range anxiety' from shorter driving distances between charges as well as the (in)ability to recharge batteries during travel are major obstacles for EVs in the consumer market (Egbue and Long, 2012). In 2019, the total number of EV charging stations in the US reached around 28,400 with nearly 94,000 outlets (U.S. Department of Energy, 2020). The state of California, which is the largest EV market in the US, has more than 6900 stations and more than 29,500 outlets (U.S. Department of Energy, 2020). However, only 14.6% of all charging stations in the US provide Level 3 fast-charging service and the current

number of Level 3 fast-charging stations cannot fulfill the demand for fast charging throughout most of the country (U. S. Department of Energy, 2020).

Potential problems associated with this supply–demand imbalance include long waiting times at fastcharging stations and/or long detour distances to find an EV fast-charging station. Clearly, there is a significant need to invest in and expand EV fast-charging infrastructure capacity in order to support the growth of the EV market. This need is well known by both governmental agencies looking to support EVs and car manufacturers who are selling EVs. In addition to strategic planning, there is also a need to manage the EV fast-charging capacity efficiently at individual stations and across a region of fast-charging stations. Given the expected rapid growth rate of EVs over the next decade or two, there are likely to be imbalances between the supply of fast-chargers and the demand for fast charging, even as public sector and private companies work to expand fast-charging capacity. Managing supply and demand at the individual station level and across a regional system of fastcharging stations is important for minimizing user wait times at fast-charging stations and utilizing existing capacity effectively at fast-charging stations. Moreover, when demand outpaces supply in an area, demand-responsive pricing-based management strategies can generate revenue to support the funding and financing of additional fast-charging capacity to balance supply with demand in the long run.

#### **Electric vehicles vs. Gasoline vehicles**

GVs dominate the personal vehicle market and are a relevant reference point to compare with the service quality offered by EVs. There are several key differences between EVs and GVs in terms of recharging and refueling that have implications for the planning and management of EV fast-charging infrastructure. First, in one important way, recharging an EV is more flexible than refueling a GV. Unlike GV that are almost exclusively refueled at dedicated gasoline refueling stations, an EV can be recharged in at least three different types of places—at a dedicated EV recharging station, in a general parking lot with installed chargers (e.g., at workplaces, shopping centers, etc.), or at the EV owner’s house. Home-installed chargers are typically Level 1 or Level 2 chargers while Level 3 chargers are only available at dedicated charging stations because of power supply and safety concerns. Home- and workplace-installed ‘slow’ chargers are mainly used for destination charging, while public fast-chargers aim to facilitate en-route charging, particularly for long-distance trips. Second, the average range of an EV when fully charged is typically shorter than that of a similar GV. Although the average travel range of EVs has steadily increased in recent years, range-anxiety is still a concern for current and potential EV owners. The average range for an EV sedan is around 200 miles, which is only one-half to two-thirds the range of a typical GV sedan. This range issue has implications in terms of the frequency with which EV owners need to recharge and also the spatial distribution of EV fast-charging stations needed to support (long-distance) EV travel. Properly sizing and siting fast-charging stations is mainly a planning level challenge; however, these stations also need to be managed efficiently, particularly when demand outpaces supply (in certain areas, during certain times of the day). Third, and most importantly from a real-time management perspective, the recharging time of an EV is considerably longer than the refueling time of a GV. Even with a 50 kW Level 3 fast charger, to recharge an EV from empty to 80% capacity takes thirty minutes to an hour. Hence, if an EV does require the use of an EV fast-charging facility, the vehicle may occupy a charger at the station for a significantly longer period of time than a GV does at a gasoline station. Moreover, if an EV user goes to a recharging station with a queue, he/she may have to wait an extended period of time to even begin recharging. When a limited number of EV fast-charging stations are constructed along

a high-volume corridor, a spike in local demand may create queues at one or more EV recharging stations, thereby inconveniencing EV users who need to recharge but do not have many alternative fast-charging stations nearby.

### EV charging technology

The types of chargers usually found in public EV charging stations in North America are the J1772, the **CCS (Combined Charging System)**, the CHAdeMO (abbreviation of “Charge de Move”), and the Tesla Supercharger. The first one is a Level 2 charger, while the other three include Level 3 **Direct Current Fast Charging (DCFC)** chargers (they are also capable of lower level charging). Table 1 summarizes EV charger types from Level 1 to Level 4. As mentioned previously, Level 3 chargers are 8 to 12 times more efficient than Level 2 chargers. Level 4 charging—also called **Extreme Fast Charging (XFC)**—is not currently available. Level 4 chargers could further improve charging efficiency and narrow the current refueling/recharging time difference between EVs and GVs.

Table 7.2 shows that compared with Level 2 chargers, Level 3 and 4 chargers have considerably more output power and therefore require higher voltage. The large loads from fast-charging stations will ultimately become a burden for electric grids and may cause system failures in the worst-case scenario. Studies have been done on both supply and demand sides of EV charging to avoid the situation. On the supply side, researchers propose methods of upgrading infrastructure and integrating fast-charging stations into the grid (Aggeler et al., 2010; Dharmakeerthi, Mithulananthan, & Saha, 2012; Guo, Deride, & Fan, 2016; Burnham et al., 2017; Chen et al., 2017; Iyer et al., 2018). On the demand side, researchers use multiple approaches to model demand and propose control schemes (e.g. pricing) to balance the spatial and temporal demand for charging (Cao et al., 2012; Chen & Frank, 2001; Flath et al., 2014).

Level	Connector Type	Current Type	Voltage (V)	Power (kW)	Charging Time (Empty Battery)	Avg. Dist. per Min Charging (Mile/Min)
1	J1772	AC	120	1.4	250 miles/400 km: 43 h	0.1
2	J1772	AC	240	3 ~ 20, typically 6	250 miles/400 km: 11 h	0.4
3	CHAdeMO	DC	Up to 500	usually 50	80% of 250 miles/400 km: 60 min	3.2
3	Tesla Supercharger	DC	400	120	80% of 315miles/500 km: 40 min	5.6
4	CHAdeMO 2.0	DC	800 ~ 1000	greater than 400	250 miles/400 km: 20 min	22

Authors summary and interpretation of multiple sources:

- <https://chargehub.com/en/electric-car-charging-guide.html#chargingconnectors>
- <https://greentransportation.info/ev-charging/range-confidence/chap8-tech/ev-dc-fast-charging-standards-chademo-ccs-sae-combo-tesla-supercharger-etc.html>
- <https://www.chademo.com/portfolios/sumitomo-electric-1-2/>

Table 7.2: *Summary of Common Level 1 to Level 4 Charging Facilities in North America* is licensed under [CC BY 4.0](https://creativecommons.org/licenses/by/4.0/)

## CHARGING STATION LOCATION

### EV charging demand and station choice behavior

Understanding and effectively capturing spatial-temporal demand patterns and EV user behavior is a crucial component for developing models to support the real-time management of a system of EV fast-charging stations. The relevant behavioral attributes in much of the EV station choice literature include, charging cost (Jabeen et al., 2013; Wen, MacKenzie and Keith, 2016; Daina, Sivakumar and Polak, 2017; Ge, MacKenzie and Keith, 2018), distance or detour distance to charging stations (Daina, Polak and Sivakumar, 2015; Sun, Yamamoto and Morikawa, 2016; Yang et al., 2016), as well as EV state of charge (SOC) and/or charging time (Sun, Yamamoto and Morikawa, 2015; Yang et al.,

2016; Xu et al., 2017; Pan, Yao and MacKenzie, 2019). The model in the current study considers the following factors: charging price at each EV fast-charging station, detour distance for an EV driver to visit each station, and expected wait time at each station.

The behavioral modeling approaches in the literature include the multinomial logit (MNL) (Jabeen et al., 2013; Daina et al., 2017), the mixed logit (Sun, Yamamoto and Morikawa, 2015, 2016; Xu et al., 2017) and the nested logit (Yang et al., 2016), which are all discrete choice modeling approaches. Other modeling approaches for charging behavior include those by Kang & Recker (2009) who use an activity-based model and by Hu, Dong, & Lin (2019) who model choices based on cumulative prospect theory. In Jabeen et al. (2013), the charging choice is whether to charge at home, at work, or at public stations. The three alternatives are independent, as such the study employs the MNL model. The mixed logit model is appropriate when there is unobserved heterogeneity among users, differences in tastes, and/or when using panel data (Sun, Yamamoto and Morikawa, 2015). In Yang et al. (2016), the choice of charging is integrated with routing and the authors employ a nested logit model for route and charging choices. See Train (2009) for an overview of discrete choice models and their applications.

### **Management and pricing of EV Fast-charging stations**

This section reviews literature associated with managing EV charging stations via using different pricing strategies. One important application of pricing schemes is to manage and balance EV charging demand. These management schemes include Price Based (PB) and Demand Response (DR) Programs in electricity markets (Albadi and El-Saadany, 2008).

PB management programs are usually based on **Time-of-Use (TOU)** pricing or real-time pricing (RTP). TOU pricing involves charging users separate prices for peak and off-peak hours in order to shift loads from peak to non-peak periods. TOU prices are usually provided to users in advance; therefore, they cannot be used to respond to within-period demand stochasticity. TOU related studies include Cao et al., (2012) and Bayram et al. (2015).

RTP involves dynamic price changes based on current demand levels. Chen & Frank (2001) study general service price adjustments based on the state of queues. Their study assumes that firms are capable of changing prices and that customers adjust behaviors based on queue states. Their results indicate that firms can increase surpluses while social welfare increases, under homogeneous customer behavior. Chen et al. (2017a) design an RTP mechanism based on an automatic DR strategy for Photovoltaic-assisted charging stations. Luo, Huang and Gupta (2018) consider a case for stochastic dynamic pricing where renewable resources and energy storage are integrated to charging suppliers.

The management approach in this paper involves RTP under which fast-charging station prices are dynamically adjusted based on current demand levels, i.e. DDRPA schemes. It extends the setting in Chen & Frank (2001) to a larger area with multiple EV fastcharging stations managed by the same entity. This paper describes schemes that enable heterogeneous pricing across stations based on the current state of each individual station, which is unlike the spatial or area pricing schemes used in earlier literature.

It is worth noting that several studies in the literature model the dynamic interplay between the electric grid power supply and EV charging station energy acquisition for management purposes (Dharmakeerthi, Mithulananthan and Saha, 2012, 2014; Sbordone et al., 2015; Khan, Ahmad and Alam, 2019). Future research may combine the user-and-EV station dynamic models and

management strategies in the current paper, with the EV station-and-power grid dynamic models and management strategies in the literature.

## SMART CHARGING

The unique aspect of EV charging is that the charging process can be controlled in time. For example, if an EV that needs 20kWh is connected for 8h to a 10kW charger, then upto 80 kWh can be delivered. But since only 20 kWh is needed, the charging can be done either at a lower power, moved in time to occur for any 2 hours within the 8 hours or done in parts. This flexibility in EV charging can be used for various applications such as increase the use of renewables or lower the charging costs. In the future, electric vehicles can even operate as a backup for the grid on a relatively large scale. In case of a short duration failure, EVs can be connected to the grid, to our homes or to loads and can be controlled to provide emergency power via Vehicle to Grid (V2G) charging. Pavol Bauer will teach you this concept in his lecture below.



One or more interactive elements has been excluded from this version of the text. You can view them online here: <https://uta.pressbooks.pub/sustainablemobility/?p=311#oembed-4>

## ICT ASPECTS OF ELECTRIC CHARGING

Charging electric cars is part of an evolving ecosystem with many different components and stakeholders that must be able to exchange information automatically. For example, charging systems today require communication between the EV user, his/her charging card, payment portal, charge point operator to do a simple AC charging of an EV in the public terrain. With the advent of smart charging, this ecosystem is expanded even further to include players like the distribution system operator, the transmission system operator and the balance responsible party. In this video, Auke Hoekstra will explain how you can use a range of ICT protocols to do just that.



One or more interactive elements has been excluded from this version of the text. You can view them online here: <https://uta.pressbooks.pub/sustainablemobility/?p=311#oembed-5>

### Case study: ABB EV charging infrastructure

Now that we have learnt about all the EV charging concepts, let us now look at how it is done in the real world. For this, we will have a case study with ABB EV Charging Infrastructure (<http://new.abb.com/ev-charging>) and meet with Crijn Bouwman, Vice President of Product Management.

ABB specializes in DC fast chargers ranging from 50kW to 150kW (Chademo, Combo, GB/T) with modular chargers going upto 400kW. They also offer AC charging solutions for electric cars and overnight and opportunity chargers for busses and trucks.



One or more interactive elements has been excluded from this version of the text. You can view them online here: <https://uta.pressbooks.pub/sustainablemobility/?p=311#oembed-6>

## Key Takeaways

- There are various charging methods for EVs. The three common ways are conductive charging, inductive charging and battery swap.
- Conductive charging is the most common charging method right now and it has two categories: AC and DC charging. The second method is inductive charging and consists of two types: static and dynamic charging.
- There are several benefits of smart charging and it has huge potential: EV charging can be controlled based on renewable generation, energy prices, grid loading and how the EV can be used as a storage and as an emergency power supply.
- Climate change in turn affect how a transportation system is planned, designed, and operated in the future.

## Self-Test



An interactive H5P element has been excluded from this version of the text. You can view it online here: <https://uta.pressbooks.pub/sustainablemobility/?p=311#h5p-7>

## GLOSSARY: KEY TERMS

**CCS (Combined Charging System):** The Combined Charging System (CCS) is a standard for charging electric vehicles. It can use Combo 1 (CCS1) or Combo 2 (CCS2) connectors to provide power at up to 350 kilowatts (kW) (max 500 amps).

**Direct Current Fast Charging (DCFC):** DC fast chargers convert AC power to DC within the charging station and deliver DC power directly to the battery.

**Extreme Fast Charging (XFC):** XFC is defined as the ability to replace at least 80% of the vehicle battery capacity in 15 min or less, or to replenish range at a rate of ~20 miles per minute of charge.

**Range Anxiety:** Range anxiety, a term commonly associated with electric vehicles (EVs), refers to the apprehension and worry experienced by EV owners about the adequacy of their vehicle's battery charge to complete a journey or the availability of charging stations along the way.

**Time-of-Use (TOU):** Time-Of-Use (TOU) pricing is a variable rate structure that charges for energy depending on the time of day and the season the energy is used. With TOU rates, your bill will be determined by both when you use electricity and how much you use.

**Vehicle-to-Grid (V2G):** V2G, technology is smart charging tech that allows car batteries to give back to the power grid.

## MEDIA ATTRIBUTIONS

### Figures

- Figure 7.1: [Conductive Charging- AC by Electric Cars: Technology](#) is licensed under [CC BY-NC-SA 4.0](#)
- Figure 7.2: [Conductive Charging- DC by Electric Cars: Technology](#) is licensed under [CC BY-NC-SA 4.0](#)
- Figure 7.3: [Inductive Charging- Static by Electric Cars: Technology](#) is licensed under [CC BY-NC-SA 4.0](#)
- Figure 7.4: [Inductive Charging- Dynamic by Electric Cars: Technology](#) is licensed under [CC BY-NC-SA 4.0](#)
- Figure 7.5: [AC Charging Operations by Electric Cars: Technology](#) is licensed under [CC BY-NC-SA 4.0](#)

### Tables

- [Table 7.1](#) is licensed under [CC BY-NC-SA 4.0](#)
- [Table 7.2: Summary of Common Level 1 to Level 4 Charging Facilities in North America](#) is licensed under [CC BY 4.0](#)

### Videos

- Video 1: [Introduction to Charging Methods of EVs](#) is available for free via <http://www.online-learning.tudelft.nl> © TU Delft, released under a CC BY NC SA license: [https://creativecommons.org/licences/...](https://creativecommons.org/licences/)
- Video 2: [AC Charging of EVs](#) is available for free via <http://www.online-learning.tudelft.nl> © TU Delft, released under a CC BY NC SA license: [https://creativecommons.org/licences/...](https://creativecommons.org/licences/)
- Video 3: [DC Charging of EVs](#) is available for free via <http://www.online-learning.tudelft.nl> © TU Delft, released under a CC BY NC SA license: [https://creativecommons.org/licences/...](https://creativecommons.org/licences/)

- Video 4: [Smart Charging and V2G](http://www.online-learning.tudelft.nl) is available for free via <http://www.online-learning.tudelft.nl> © TU Delft, released under a CC BY NC SA license: <https://creativecommons.org/licences/...>
- Video 5: [Charging of Electric Vehicles ICT Aspects of Electric Charging](http://www.online-learning.tudelft.nl) is available for free via <http://www.online-learning.tudelft.nl> © TU Delft, released under a CC BY NC SA license: <https://creativecommons.org/licences/...>
- Video 6: [Case Study ABB](http://www.online-learning.tudelft.nl) is available for free via <http://www.online-learning.tudelft.nl> © TU Delft, released under a CC BY NC SA license: <https://creativecommons.org/licences/...>

## REFERENCES

- [Bending the Curve: Climate Change Solutions](#) by Ramanathan, V., Aines, R., Auffhammer, M., Barth, M., Cole, J., Forman, F., et al. is licensed by the following creative commons license: [CC BY-NC-SA 4.0](#)

## ATTRIBUTIONS

- [Bending the Curve: Climate Change Solutions](#) by Ramanathan, V., Aines, R., Auffhammer, M., Barth, M., Cole, J., Forman, F., et al. is licensed under [CC BY-NC-SA 4.0](#)
- [Dynamic modeling and real-time management of a system of EV fast-charging stations](#) by Yang, D., Sarma, N., Hyland, M., & Jayakrishnan, R is licensed under [CC BY 4.0 Deed](#)
- [Electric Cars: Technology](#) by [TU Delft OpenCourseWare](#) is licensed under a [Creative Commons Attribution-NonCommercial-ShareAlike 4.0 International License](#).



## CHAPTER 8: SHARED MOBILITY AND AUTOMATION

---

### CHAPTER OVERVIEW

In this chapter, we discuss the potential of vehicle sharing and automation to minimize the need for additional vehicles on the road and eventually reduce vehicle miles traveled (VMT). However, the focus of this chapter is to look at the unintended consequences of these technologies; specifically, the ‘rebound effect’ or the ‘induced demand’. Additionally, we will elucidate on the inefficient operation, inequitable distribution, and inadequate infrastructure related to these technologies.

#### Chapter Topics

1. [Shared Mobility](#)
2. [Automation in Transportation](#)
3. [Induced Demand from Shared Automated Transportation](#)
4. [VMT Reduction Methods](#)
5. [Transportation Efficiency Improvement](#)
6. [Effect of Vehicle Automation](#)

#### Learning Objectives

At the end of the chapter, the reader should be able to do the following:

- Design curb space for shared automated fleets.
- Develop a framework to analyze sustainability of any emerging transportation technology based on first principles.
- Apply the concept of induced demand to calculate the short-term activity change and the long-term behavioral changes stemmed from adoption of emerging transportation technologies.

### SHARED MOBILITY

The revolution of shared mobility started with the concept of **On-Demand Mobility Services**. On-demand mobility services involves arranging for travel on-demand. Usually, the travelers request their “rides” on automobile or **paratransit** using a smartphone app. The service provider typically manages a fleet of vehicles and optimizes the vehicles’ locations and route assignments based on the dynamic demand of subscribers. Greenblatt and Shaheen (2017) classified on-demand mobility services in four major categories – **transport network companies** (TNCs), carsharing, ridesharing, and e-hailing.

TNCs such as Uber and Lyft match drivers who subscribe to their platform with trip requests from individuals. Most of the trip requests are from single travelers; therefore, the majority of the TNC trips are not shared rides. For example, according to a recent study in Boston the average occupancy rate for TNC trips is 1.5, including the driver. To promote ridesharing, major TNCs offer shared ride service options such as UberPOOL and Lyft Line in major cities. However, only a small fraction of users who have access to these shared ride options request them, and even a smaller fraction of those trip requests are actually matched as shared rides.

Carsharing is subscription-based mobility where subscribers pay a short-term fee. Zipcar is an example of typical carsharing services. On the other hand, the traditional carpooling and vanpooling fall under the ridesharing category. Ridesharing through microtransit services such as Via, Chariot, and Flex is considered a potential mobility solution in highly dispersed urban areas. E-hailing services matches traditional for-hire taxis to the nearest passengers using apps similar to TNCs. As in the case of TNCs, these on-demand mobility services only reduce the total number of trips when shared rides happen.

Although on-demand mobility services include other modes such as bicycle and scooter, we have purposefully limited the discussion in this chapter to exclude those modes. We assume that mobility decisions taken by the users of those modes will not significantly impact vehicle emissions (e.g., through mode shift). In addition, TNCs will be a focal point of our discussion regarding the impacts of on-demand mobility services because the current market share of all the other categories combined is inappreciable compared to that of TNCs.

## AUTOMATION IN TRANSPORTATION

The US personal mobility market is valued at around one trillion dollars (Walker and Johnson, 2016). In recent years, the promises of sensing, communication, and artificial intelligence technologies have attracted billions of dollars in investments to develop connected and automated vehicles. These investments were predominantly made by ‘Silicon Valley’ companies, and since almost all the traditional automotive manufacturers have followed suit.

The Society of Automotive Engineers (SAE) defines five levels of driving automation in its J3016 taxonomy (SAE, 2016). The levels increase from 0 to 5 with a higher level representing lesser intervention and attention from the human driver. Level 3 to level 5 automation, according to SAE, represents automated driving features such as traffic jam chauffeur, local driverless taxi, and steering wheel-free driving.

Connectivity allows for the exchange of information between vehicle and infrastructure. Information exchange among vehicles, termed as vehicle-to-vehicle (V2V) communication has enabled several applications in the safety, mobility, and environmental domains. Examples of such applications are forward collision warning (safety), advanced traveler information (mobility), and eco-driving (environment). Vehicle to infrastructure (V2I) communication has capacitated additional applications such as red-light violation warning (safety), transit signal priority (mobility), and eco-approach and departure (environment) . The US National Highway Traffic Safety Administration (NHTSA) proposed inclusion of V2V connectivity in all new-light duty vehicles and trucks in 2016.

## INDUCED DEMAND FROM SHARED AUTOMATED TRANSPORTATION

On-demand mobility services, especially those offered by TNCs, operate on a premise that people will not own vehicles, and rather use these services to meet their travel needs. In the case of TNCs,

users often spend time by curbside waiting for the vehicles to pick them up. This could translate to an increase in the amount of time spent in the microenvironment with a higher level of traffic-related air pollution as compared to using personal vehicles. The extent of the increase in exposure to traffic emissions will depend on a number of factors such as the frequency of service use, the pick-up locations, and the level of traffic emissions at those locations.

Current TNC operation is primarily based on existing vehicle and fuel technologies and is expected to remain the same in the near future. However, TNCs are likely to be early adopters of fuel-efficient vehicle and alternative fuel technologies as fuel cost accounts for a significant portion of their total operation costs. Hu et al. (2018) studied New York city taxi trips and found that 94% of TNC shifts needed to serve those trips are shorter than 200 miles. Considering the range of current electric vehicles in the market, TNC drivers can practically switch to electric vehicles.

On-demand mobility services that do not convert non-motorized and transit trips to vehicle trips and that promote ridesharing are expected to reduce the total VMT on the roadways, which would result in a reduction in emissions. Alonso-Mora et al. (2017) compared 14,000 New York city taxi trips with a hypothetical ride-sharing operation. They found that 98% of the total taxi trips could be replaced by 3,000 ride-share vehicles with capacity of 4 passengers per vehicle or 2,000 vehicles with 10 passengers per vehicle. Bischoff and Maciejewski (2016) simulated trips from 1.1 million personal vehicles in the city of Berlin, Germany, and found that a fleet of 100,000 shared autonomous vehicles would be able to serve those trips sufficiently. In these simulation studies, no barriers to adoption of ride sharing were assumed and, therefore, they represent an ideal scenario.

Evidence of the real-world impacts of TNCs, especially on VMT and congestion, has begun to emerge recently. In the short term, TNCs can incur a significant amount of "deadhead" miles, which are the miles where the driver is driving without any passenger, such as from the drop-off location of one trip to the pick-up location of the next trip (Wenzel et al. 2019). A recent paper (Komanduri et al. 2018) using RideAustin data estimated that 37% of all the miles are due to deadheading. It was estimated to be around 20% in San Francisco (Castiglione et al, 2018) and about 50% in New York City (Schaller, 2018). Castillo et al. (2018) presented a condition of matching failure by TNCs where there are fewer number of available vehicles nearby than there are trip requests. Such failure may contribute to a substantially increased amount of deadhead miles. The number of these empty passenger trips can be reduced significantly by imposing an adaptive matching radii within which the driver supply and trip demand matching must occur (Xu et al., 2019).

In longer term, TNCs may complement public transit by providing first and last mile services, or decrease transit ridership by competing. Hall et al. (2018) found that transit ridership decreased by 5.9% in smaller cities but increased by 0.8% in larger cities due to the entry of Uber. Also, small transit agencies in big cities received the most complementing effect from Uber. Clewlow and Mishra (2017) surveyed more than 4,000 residents in 7 large cities in the US and found that 15% of public transit, 17% walk, and 7% bike trips were replaced by TNC trips, and that induced trips—trips which did not have happened if TNC service was not there—consisted of 22% of the total trips. A similar study by Henao and Marshall (2018) conducted in Denver, Colorado, found that public transit trips replaced by TNCs and induced TNC trips were 22% and 12%, respectively.

Evidence to date has pointed in the direction that TNCs, in the way they are operated and used currently, increase VMT, which has also resulted in increased traffic congestion in some areas. As a result, traffic-related emissions will likely also increase. However, it should be noted that any increase in VMT caused by TNCs will not increase traffic emissions if those miles are zero-emission miles.

And if TNCs' zero-emission miles can displace some of the personal vehicles' gasoline miles, there can be a net reduction in total traffic emissions. For example, Bauer et al. (2018) showed that a centrally managed shared autonomous electric taxi fleet in Manhattan Island of New York City would yield 58% reduction in energy consumption and 73% reduction in greenhouse gas (GHG) emissions as compared to an autonomous fleet of conventional gasoline vehicles.

In terms of equity point of view, there is a large variation in the usage of TNCs among population in different income groups. According to the 2017 National Household Travel Survey (NHTS) in 9 major metropolitan areas, people with annual income more than \$200,000 made 44 TNC trips per year, whereas people with annual income less than \$15,000 made only 6 TNC trips. Thus, the increase in traffic emissions generated by TNCs are contributed more by high-income population. It is unclear, however, how the air quality and health impacts of those increased emissions are distributed in the environmental justice context.

While the real-world testing and demonstration of CAVs to date have shown potential for emissions reduction in the near term, primarily as a result of improved vehicle and traffic operational efficiency, the long-term impacts of these technologies on traffic emissions are unclear as there is no real-world evidence at this time. One speculative long-term impact is that the expanded and inexpensive mobility provided by CAVs may cause increased trip frequency and, consequently, higher VMT. Wadud et al. (2016) estimated VMT increase of 4% -60% due to the reduced cost of drivers' time. Meyer et al. (2017) suggested that autonomous vehicles could increase accessibility in suburban areas by 10% to 14%. Such increase in accessibility may translate to urban sprawl and result in increased trip length. These uncertain yet potentially significant impacts of CAVs may result in an overall increase in emissions in the long run.

## VMT REDUCTION METHODS

As described earlier, total VMT in the US continues to grow at a steady pace. VMT was flat from 2008 to 2012, primarily because of the economic recession, but has been increasing since then.

In terms of potentially reducing VMT, we can refer back to a variety of mobility measures outlined in previous chapters. In general, these include the following:

- Use pricing mechanisms to encourage users to reduce the number and distance of their trips and increase the number of passengers per vehicle. Several regions across the US are already increasing the number of toll and commuter lanes on their roadway networks, while cities such as Singapore, London, and Stockholm have implemented congestion pricing schemes that charge drivers to enter the city center.
- Provide incentives for using alternative modes such as transit and biking, as well as shifting work locations and schedules, for instance by telecommuting.
- Reduce urban sprawl, increase land use densities, and improve the mix of jobs and housing.

## TRANSPORTATION EFFICIENCY IMPROVEMENT

Another important strategy for reducing emissions from transportation is to improve the efficiency of transportation system operations. As described above, today's transportation systems are often congested, which wastes time, money, and fuel. This wasted fuel translates to increased pollutant and GHG emissions. Over the last several decades, a number of **intelligent transportation system**

( ITS) techniques have emerged that are squarely aimed at reducing these environmental impacts. ITS techniques and applications target three general areas: (1) congestion mitigation (for example, advanced signal control, predictive ramp metering, incident management), whereby congestion is reduced and speeds increased; (2) better management of speeds for different roadway types, using techniques such as variable speed limits and intelligent speed adaptation; and (3) smoothing of traffic by using techniques such as **cooperative adaptive cruise control** and **speed harmonization**. These “eco-friendly” intelligent transportation system technologies are typically categorized into three areas: vehicle systems, traffic management systems, and travel information systems.

### **Vehicle Systems Improvement**

Vehicle systems represent vehicle features and functions that allow a vehicle to “see,” respond to, and communicate with its surroundings. Sensors such as on-board radar and computer vision technologies enable a vehicle to monitor the distance to the vehicle in front and to detect when a vehicle is leaving a lane, and they support adaptive cruise control systems that allow a driver to select a desired speed and set a following distance. In addition, communication devices (for example, dedicated short-range communications, cellular) will likely be deployed to enable vehicle-to-vehicle, vehicle-to-infrastructure, and infrastructure-to- vehicle applications that are primarily focused on improving safety. It is important to point out that improved anticollision systems may have a significant indirect energy and emissions savings: fewer crashes result in less congestion, allowing for higher average traffic speeds with less stop and go. In addition to safety applications, a variety of mobility and environmental applications have also emerged, as illustrated in Table 8.1. These applications take advantage of connected vehicle technology such as cooperative adaptive cruise control where vehicles communicate with each other to cooperatively manage following distance, braking, accelerating, and more. These technologies are allowing vehicles to become increasingly automated, with the goal of full vehicle automation coming in the next decade.

---

### *V2I Safety*

- Red light violation warning
- Curve speed warning
- Stop sign gap assist
- Spot weather impact warning
- Reduced speed/work zone warning
- Pedestrian in signalized crosswalk warning (transit)

### *V2V Safety*

- Emergency electronic brake lights
- Forward collision warning
- Intersection movement assist
- Left turn assist
- Blind spot/lane change warning
- Do not pass warning
- Vehicle turning right in front of bus warning (transit)

### *Agency Data*

- Probe-based pavement maintenance
- Probe-enabled traffic monitoring
- Vehicle classification-based traffic studies
- CV-enabled turning movement & intersection analysis
- CV-enabled origin-destination studies
- Work zone traveler information

### *Environment*

- Eco-approach and departure at signalized intersections
- Eco-traffic signal timing
- Eco-traffic signal priority
- Connected eco-driving
- Wireless inductive/resonance charging
- Eco-lanes management
- Eco-speed harmonization
- Eco-cooperative adaptive cruise control
- Eco-traveler information
- Eco-ramp metering

### *104 Smart Transitions zone management*

- AFV charging/fueling information
- Eco-smart parking

### *Road Weather*

- Motorist advisories and warnings (MAW)
- Enhanced MDSS
- Vehicle data translator
- Weather response traffic information (WxTINFO)

### *Mobility*

- Advanced traveler information system
- Intelligent traffic signal system (I-SIG)
- Signal priority (transit, freight)
- Mobile accessible pedestrian signal system (PED-SIG)
- Emergency vehicle preemption (PREEMPT)
- Dynamic speed harmonization (SPD-HARM)
- Queue warning (Q-WARN)
- Cooperative adaptive cruise control (CACC)
- Incident scene pre-arrival staging guidance for emergency responders (RESP-STG)
- Incident scene work zone alerts for drivers and workers (INC-ZONE)
- Emergency communications and evacuation (EVAC)
- Connection protection (T-CONNECT)
- Dynamic transit operations (T-DISP)
- Dynamic ridesharing (D-RIDE)
- Freight-specific dynamic travel planning and performance
- Drayage optimization

### *Smart Roadside*

- Wireless inspection
- Smart truck parking

Table 8.1: Intelligent transportation system applications utilizing connected and automated vehicle technology from ["Bending the Curve: Climate Change Solutions"](#) by Ramanathan et al. is under the following Creative Commons license: [CC BY-NC-SA 4.0](#)

### **Traffic Management Systems Improvement**

Traffic management systems have become more sophisticated with the advent of better sensor technology, more reliable communication channels, and advanced information processing. Transportation managers are better equipped to estimate traffic conditions, detect and remove traffic incidents, and craft better travel demand management strategies (that is, manage the number of vehicles on a congested roadway). The overarching goal of traffic management is to take full advantage of the existing roadway capacity, thus keeping traffic flowing smoothly at moderate speeds. In doing so, it will have a large impact in reducing energy consumption and GHG emissions from each vehicle. In addition, traffic management system strategies go even further by reducing the number of vehicles and VMT in the transportation network without compromising overall travel needs, thereby reducing the total contributions of energy consumption and emissions from the transportation sector.

### **Travel Information Systems Improvement**

Travel information systems provide information to drivers, such as route guidance systems, geolocation systems, and electronic payment systems. All of these systems add convenience to the traveler while reducing energy consumption and emissions. For example, a route guidance system will cut back on unnecessary travel that may occur when a driver gets lost or chooses a long, out-of-the-way path. En route driver information can reduce energy and emissions associated with driving around in search of a specific location or parking. Electronic payment systems also eliminate the need for a driver to decelerate the vehicle, idle while a manual transaction takes place, and then accelerate the vehicle back to a desired speed. If this payment can occur without slowing down, energy consumption and emissions are greatly reduced.

In general, environmentally friendly ITS applications (that is, specific ITS applications that reduce energy and emissions) have slowly been emerging over the last decade, as have safety and mobility programs mentioned in Table 8.1. Pioneering research programs in the US, the European Union, and other regions have made significant progress in developing and testing these ITS applications and technologies with a focus on environmental benefits. From these research programs, it is clear that specific environmental benefits can be maximized when different ITS applications are “tuned” so that emissions and energy consumption are reduced. The actual energy and emissions savings vary, but they are typically on the order of 5% to 20%. It is important to point out that there is not a single ITS technology solution that has demonstrated a large reduction in energy consumption and emissions. But since most of these applications are additive, greater benefits may be achieved when a combination of environmentally friendly ITS programs is put into place.

## **EFFECT OF VEHICLE AUTOMATION**

In recent years, interest in vehicle automation has soared. Some reports have predicted that vehicles could be fully automated (that is, not requiring a driver) by as early as 2025, though this is highly unlikely other than in tightly bounded areas with easy driving conditions. As an extension of ITS, vehicle automation could have both positive and negative effects on society (Figure 8.1). Vehicle automation could lead to reduced emissions, due to congestion reduction (for example, crash

avoidance, platooning), traffic smoothing (for example, cooperative adaptive cruise control), and better speed management (for example, speed harmonization). Indeed, eco-driving behaviors could be directly programmed into the automated vehicle operation. On the other hand, vehicle automation could potentially increase emissions by increasing vehicle travel. People might use their automated vehicles for additional purposes or choose a more distant place to live, since the time cost of travel would be reduced. Automated vehicles could be used by a wider range of users, including youth and elderly. “Drop-off” errands might increase, resulting in new empty vehicle relocation trips, such as returning home without any passengers. Some early conclusions regarding automated vehicles include the following:

- Partial and full automation can reduce energy use and emissions, but only if incentives exist to encourage pooled use of vehicles.
- Automated vehicles that communicate and coordinate with other vehicles and the infrastructure will likely have greater improvements in safety, mobility, and the environment compared with autonomous vehicles without those capabilities.
- Automated vehicles have the strong potential to induce travel demand, unless incentives exist for pooled use of the vehicles.



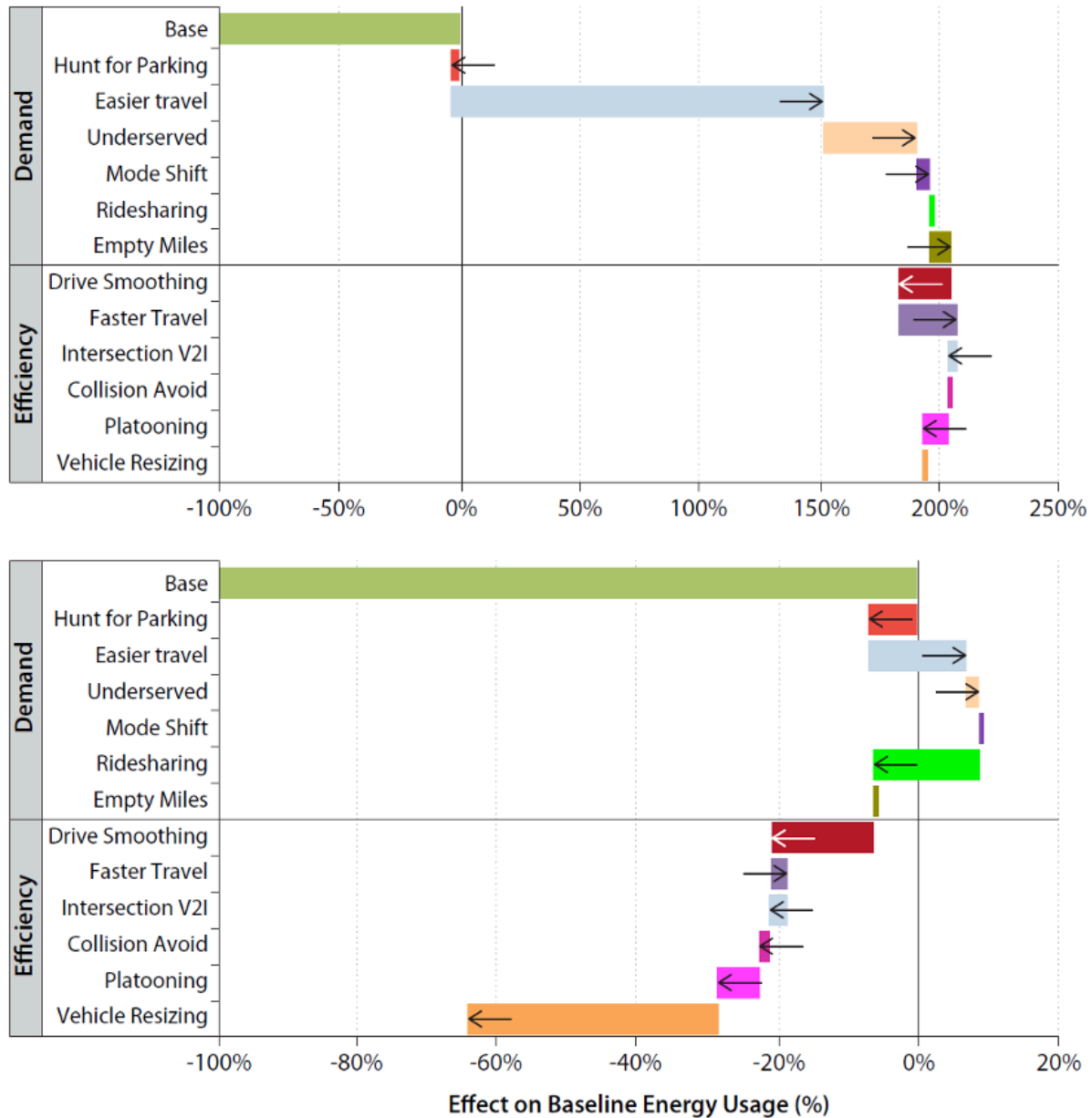

Figure 8.1: Potential energy/emissions impacts of automated technology. The upper-bound case is shown in the top panel, and the lower-bound case in the lower panel. *"Bending the Curve: Climate Change Solutions"* by Ramanathan et al. is under the following Creative Commons license: [CC BY-NC-SA 4.0](https://creativecommons.org/licenses/by-nc-sa/4.0/)

### Key Takeaways

- There are generally four different ways to mitigate transportation emissions: through vehicle technology, low-carbon fuels, VMT management, and intelligent transportation systems, including the use of connected and automated vehicles.
- VMT can be reduced by increasing the use of pooled travel (for example, buses, transit, shared

mobility that is pooled).

- Other VMT reduction methods may include adopting incentives and disincentives to reflect full social costs of travel and, eventually, transitioning from individual vehicle ownership to use of mobility services that are pooled.
- Vehicle automation is likely to be deployed in the near future and should be managed so as to achieve environmental sustainability.

## Self-Test



An interactive H5P element has been excluded from this version of the text. You can view it online here:

<https://uta.pressbooks.pub/sustainablemobility/?p=350#h5p-8>

## GLOSSARY: KEY TERMS

**Cooperative Adaptive Cruise Control (CACC):** an extension to the adaptive cruise control (ACC) concept using Vehicle-to-Everything (V2X) communication. Adaptive cruise control (ACC) is a type of advanced driver-assistance system for road vehicles that automatically adjusts the vehicle speed to maintain a safe distance from vehicles ahead.

**Intelligent Transportation System (ITS):** an advanced application which aims to provide innovative services relating to different modes of transport and traffic management and enable users to be better informed and make safer, more coordinated, and ‘smarter’ use of transport networks.

**On-Demand Mobility Services:** On-demand mobility services are transport services that are available at any time that a person wants to use them, i.e., on demand.

**Paratransit:** an alternative mode of flexible passenger transportation that does not follow fixed routes or schedules, are common and often offer the only mechanized mobility options for the poor in many parts of the developing world.

**Speed Harmonization:** gradually lowering speeds before a heavily congested area in order to reduce the stop-and-go traffic that contributes to frustration and crashes.

**Transport Network Companies (TNCs):** Transportation Network Companies (TNCs) provide prearranged transportation services for compensation using an online-enabled application or platform (such as smart phone apps) to connect drivers using their personal vehicles with passengers.

## MEDIA ATTRIBUTIONS

### Figures

- Figure 8.1: Potential energy/emissions impacts of automated technology from “[Bending the Curve: Climate Change Solutions](#)” by Ramanathan et al. is under the following Creative Commons license: [CC BY-NC-SA 4.0](#)

### Tables

- Table 8.1: Intelligent transportation system applications utilizing connected and automated vehicle technology from “[Bending the Curve: Climate Change Solutions](#)” by Ramanathan et al. is under the following Creative Commons license: [CC BY-NC-SA 4.0](#)

## REFERENCES

- Alonso-Mora, J., Samaranayake, S., Wallar, A., Frazzoli, E., & Rus, D. (2017). On-demand high-capacity ride-sharing via dynamic trip-vehicle assignment. *Proceedings of the National Academy of Sciences*, 114(3), 462-467.
- Bauer, G. S., Greenblatt, J. B., & Gerke, B. F. (2018). Cost, energy, and environmental impact of automated electric taxi fleets in Manhattan. *Environmental science & technology*, 52(8), 4920-4928.
- Bischoff, J., & Maciejewski, M. (2016). Simulation of city-wide replacement of private cars with autonomous taxis in Berlin. *Procedia computer science*, 83, 237-244.
- Castiglione, J., Cooper, D., Sana, B., Tischler, D., Chang, T., Erhardt, G., Roy, S., Chen, M., & Mucci, A. (2018, October). TNCs & congestion. Draft report, San Francisco County Transportation Authority.
- Castillo, J. C., Knoepfle, D., & Weyl, G. (2017, June). Surge pricing solves the wild goose chase. In *Proceedings of the 2017 ACM Conference on Economics and Computation* (pp. 241-242). ACM.
- Greenblatt, J. B., & Shaheen, S. (2015). Automated vehicles, on-demand mobility, and environmental impacts. *Current sustainable/renewable energy reports*, 2(3), 74-81.
- Hall, J. D., Palsson, C., & Price, J. (2018). Is Uber a substitute or complement for public transit?. *Journal of Urban Economics*, 108, 36-50.
- Henao, A., & Marshall, W. E. (2018). The impact of ride-hailing on vehicle miles traveled. *Transportation*, 1-22.
- Hu, L., Dong, J., Lin, Z., & Yang, J. (2018). Analyzing battery electric vehicle feasibility from taxi travel patterns: The case study of New York City, USA. *Transportation Research Part C: Emerging Technologies*, 87, 91-104.
- Komanduri, A., Wafa, Z., Proussaloglou, K., & Jacobs, S. (2018). Assessing the impact of app-based ride share systems in an urban context: Findings from Austin. *Transportation Research*

*Record*, 2672(7), 34-46.

- Meyer, J., Becker, H., Bösch, P. M., & Axhausen, K. W. (2017). Autonomous vehicles: The next jump in accessibilities?. *Research in Transportation Economics*, 62, 80-91.
- Ramanathan, V., Aines, R., Auffhammer, M., Barth, M., Cole, J., Forman, F., et al. (2019). *Bending the Curve: Climate Change Solutions*. Location: Regents of the University of California. Editor: V. Ramanathan. Co-Editors: Adam Millard-Ball; Michelle Niemann; Scott Friese. Book published by the Regents of the Univ of California. Retrieved from <https://escholarship.org/uc/item/6kr8p5rq>. 815pp. <https://creativecommons.org/licenses/by-nc-sa/4.0/>
- SAE international. (2016). Taxonomy and definitions for terms related to driving automation systems for on-road motor vehicles. *SAE International*,(J3016).
- Schaller, B. (2018). Making Congestion Pricing Work for Traffic and Transit in New York City. *Schaller Consulting*.
- Wadud, Z., MacKenzie, D., & Leiby, P. (2016). Help or hindrance? The travel, energy and carbon impacts of highly automated vehicles. *Transportation Research Part A: Policy and Practice*, 86, 1-18.
- Walker, J., & Johnson, C. (2016). Peak car ownership: The market opportunity of electric automated mobility services. *Rocky Mountain Institute*.
- Wenzel, T., Rames, C., Kontou, E., & Henao, A. (2019). Travel and energy implications of ridesourcing service in Austin, Texas. *Transportation Research Part D: Transport and Environment*, 70, 18-34.
- Xu, Z., Yin, Y., & Ye, J. (2019). On the supply curve of ride-hailing systems. *Transportation Research Part B: Methodological*.

#### ATTRIBUTIONS

- [Bending the Curve: Climate Change Solutions](#) by Ramanathan, V., Aines, R., Auffhammer, M., Barth, M., Cole, J., Forman, F., et al. is licensed under [CC BY-NC-SA 4.0](#)

## CHAPTER 9: SUSTAINABLE FREIGHT

---

### CHAPTER OVERVIEW

In this chapter, we discuss the policies and strategies used to ensure sustainability in the freight movement process. Everything from retail to services, construction to waste collection rely on an efficient and reliable freight transport system. However, with the increasing pressures of urbanization, this has to be balanced with the environmental and social impacts caused by transport activity. This is the challenge of City Logistics, a field of study that has significant practical implications for the world and the cities we live in. It is not merely a question of what is involved, but what can be done about urban freight transport to improve it for the sake of economic efficiency, quality of life, and sustainability. This chapter will give you the tools you need to understand the complexities of urban freight transport systems.

#### Chapter Topics

1. [Sustainable Urban Freight Transport](#)
2. [Urban Freight as a System](#)
3. [City Logistics Solutions](#)
4. [Evaluation of City Logistics](#)

### Learning Objectives

At the end of the chapter, the reader should be able to do the following:

- Understand the complex nature of urban freight transport systems.
- Evaluate freight traffic impacts.
- Explore the different approaches to solving urban freight transport problems.
- Identify the research methods used to develop and apply knowledge in this field.
- Identify the main logistics challenges facing cities around the world.

### SUSTAINABLE URBAN FREIGHT TRANSPORT

Building on the definition of sustainability, we can consider a transport system to be sustainable if it contributes to overall economic growth as well as social equity, without degrading the natural environment. There are several trends that point to a strong growth of urban freight transport around the world, such as the general growth of the economy and the steep growth of e-commerce. The problem is that urban freight activity in many instances lead to direct impacts on the environment,

society and economy. Some impacts, of course, are more severe and urgent than others. The impacts, such as air and noise pollution, traffic accidents, congestion and the emissions of greenhouse gases, lead to unsustainable outcomes, such as climate change, poor health and safety outcomes, delays and, eventually, unlivable cities.

We can often get the impression that freight activity are only “bad”, but that is not the case. The freight system holds, first and foremost, a functional role, which is to facilitate the movement of freight, a function essential to the economy and living of the urban residents. Hence, any solution aimed at reducing the negative impacts of urban freight should take care that the service quality of the freight system is not too diminished either.

So, a balanced view will at least have four aspects considered:

1. Logistics service quality
2. General condition of the transport system
3. Environmental concerns and impacts
4. Social concerns

#### **Logistics service quality**

Goods delivery and pick-up can be regarded at the micro-, meso- and macro-economic level. The micro level is that of the individual firms. Shops sell their goods and order fresh produce, and city logistics operators deliver them at the required location. Accessibility, average speed, reliability and delivery costs are important here. By keeping logistic costs down, goods stay attractive for buyers. This has a positive impact on the productivity of entire sectors of the city’s economy, including construction, retail and tourism (meso level impact). This increases the volume and diversity of the goods and services available and increases the return of investments in the city, which in turn contributes to economic development (macro level impact).

#### **General condition of the transport system**

With a growing number of people living in cities, both passenger and freight transport will grow substantially. The city’s government may spend part of the tax income on infrastructure in order to keep the economy on its growth path. However, if these investments cannot keep up with the growth in traffic, congestion can become worse. This makes it more difficult to deliver goods on time and at low costs. Congestion also leads to an increase of traffic emissions (e.g. carbon monoxide). A negative cycle may start. Economic development may slow down. Companies and people may migrate away to less congested areas, creating new flows every time they want to return to the city, thereby increasing congestion. Although bad city logistics cannot be blamed for all these transport problems, it can be part of the problem – and the solution.

#### **Environmental concerns and impacts**

City logistics takes place with motorized and non-motorized vehicles and equipment. In most cases roads are used to transport the goods, but there are also examples where inland waterways and railways are used to ship goods in and out of cities. A growing use of motorized transport vehicles leads to a growing use of fossil fuels. This has many negative environmental impacts. One of these is the depletion of natural resources. The emission of carbon dioxide contributes to climate change.

Mining and production of conventional vehicle fuels damages and pollutes the environment as well. Air pollution (such as nitrogen oxides, carbon monoxide, particulate matter and sulfur dioxides) is also a well-known side effect of the combustion of fuels in engines. Particles as small or smaller than 10 micrometers (also known as PM10) result from the wear of tires and brakes. There are also other environmental effects, for instance a visual pollution or intrusion in the landscape, roads acting as physical barriers for pedestrians, or loss of green areas. Contamination of land with toxic or other hazardous materials may occur during production, maintenance and use of vehicles (e.g., loss of fluids, wear of brake pads). It may also occur during construction, maintenance and use (e.g. run-offs) of infrastructure. Finally, there is waste produced during the lifecycle of vehicles and infrastructure.

### Social concerns

The urban freight sector has an important social impact as well, both positive and negative. A positive impact is that city logistics provides many jobs, either directly or indirectly. Having a job means a higher standard of living and more diverse spending opportunities (on education etc.). Another positive impact is that efficient city logistics allows people to consume a wider range of goods. The negative social impacts of city logistics may relate to environmental effects. Air pollution, noise and safety hazards may make the city a less pleasant, less safe and it affects health. Inhalation of smoke is linked to respiratory diseases. Traffic safety, especially of vulnerable road users like cyclists and pedestrians, are difficult problems facing many cities around the world, causing unnecessarily high fatalities. One should also note that these effects are not *equally* distributed to members of society, but affect usually poorer areas.

## URBAN FREIGHT AS A SYSTEM

The domain of urban freight transport has many facets and touches our lives in different ways sometimes. So, it is important to first define the terms and concepts that will be used throughout the rest of this chapter. This will help us to be clear about what we mean when we use a specific term, and help us communicate with one another better. The next video will introduce some of these terms and fundamental concepts.



One or more interactive elements has been excluded from this version of the text. You can view them online here: <https://uta.pressbooks.pub/sustainablemobility/?p=388#oembed-1>

A systems approach to **urban distribution** is an integrated process aimed at improving performance of urban distribution systems, that involves a number of activities, including defining problems, conducting surveys, setting goals, objectives and criteria, designing alternatives, predicting and evaluating the performance of alternatives, implementing an alternative and reviewing the performance of the system (Figure 9.1).

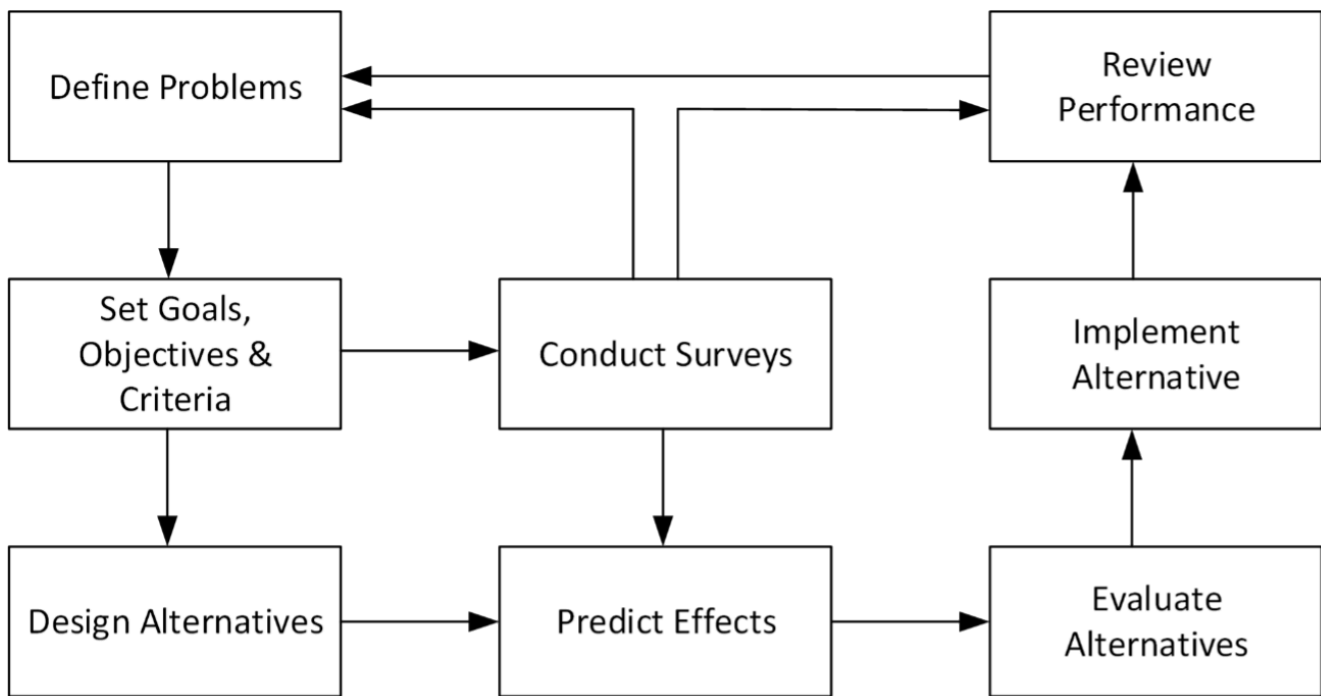

Figure 9.1: A Systems Approach to Urban Distribution from [Sustainable Urban Freight Transport: a Global Perspective](#) by through TU Delft OpenCourseWare is licensed under [Creative Commons Attribution Non-Commercial Share Alike](#).

## CITY LOGISTICS SOLUTIONS

In this chapter, we will briefly describe some of the city logistics schemes that have been studied and implemented. We will not be able to cover them all, since they are truly many (see Table 9.1). The main focus will be interesting perspectives that practitioners and researchers have in solving some of the challenges of urban freight transport.



**Table 9.1: Overview of main actions public administrators can perform and potential reactions from the private sector from *Sustainable Urban Freight Transport: A Global Perspective* is licensed under a [Creative Commons Attribution-NonCommercial-ShareAlike 4.0 International License](https://creativecommons.org/licenses/by-nc-sa/4.0/).**

Main category	Approach	Specific action	Private sector reaction
Private/Public infrastructure	Transfer points	City terminals	Incorporate spaces into logistics chain; consolidate deliveries/ collection; shift to smaller & cleaner road vehicles or other modes.
Outskirts logistic centers			
Logistic improvement of terminals			
Use of rail or ship terminals			
Use of public parking lots			
Modal shift	Use of the train or underground system		
<b>Shuttle train</b>			
Land use management	Parking	(smart) Load zone provision	Avoid on-street parking for loading and unloading activities; less congestion; higher reliability.
Parking space planning			
Hub areas			
Use of other reserved spaces			
Building regulations	Load/unload interfaces		
Use of private parking lots			
Mini-warehouse	Consolidate delivery to only one location (per block/small walkable area)		
Access conditions	Spatial restrictions	Access according to weight, volume, width, height & length	Shift to smaller vehicles (but also MORE vehicles)
Access to pedestrian zones	Shift to small/clean vehicles		
Street blocking allowance	Minimize impact of delivery activity/increase safety		
Closing the center to private traffic	Access given to freight vehicles during a time-window		
Environmental zoning restricting polluting vehicles or zero-emission zones	Reduction of emissions		
Road pricing	Overall reduction in unnecessary traffic		
Time restrictions	Adequate rotation in load zones	Increase utilization of load zones	
Night deliveries	Shift to off-hour delivery		

<b>Main category</b>	<b>Approach</b>	<b>Specific action</b>	<b>Private sector reaction</b>
Double-parking short time restrictions	Minimize impact of delivery activity		
Access time windows	Avoid congested periods or pedestrian/shopping hours		
Traffic management	Scope of regulations	Carrier classification	Apply for appropriate classification, with best traffic permissions
Freight zone classification	–		
Harmonization of regulations	–		
Street classification	–		
Information	On-line load zone reservations	Dynamic routing	

## **Access Restrictions**

### *Time Access Restrictions*

Time access restrictions, also known as time-windows, restrict trucks from entering a certain area within a certain time. The time-window area is often the city center or even a smaller part, the pedestrian area within the city center. Sometimes time-window restrictions allow delivery trucks access for a certain time period to areas where normally no motorized vehicles are allowed, such as pedestrian areas.

### *Vehicle Restrictions*

Vehicle restrictions prevent vehicles that have certain characteristics from entering a certain area (e.g., city center, specific streets). Vehicle restrictions can apply to various vehicle characteristics, such as length, width, height, axle pressure, and weight. A specific vehicle restriction, the amount of emissions emitted by the vehicle's engine, is discussed in another restriction, the low emission zone.

### *Low Emission Zones/Environmental Zones (Engine Restrictions)*

Low emission zones or environmental zones restrict polluting vehicles from entering a defined area. This can be considered an advanced type of vehicle restrictions. Usually the vehicle receives a special sticker that marks it as qualified to enter the zone.

### *Vehicle Load Factor Controls*

A vehicle's load factor should ensure that only fully (or at least to a certain extent) loaded vehicles enter an area, such as the city center. Urban freight vehicles have, on average, a low load factor (due to several reasons). Enforcement of such controls are difficult.

### *Road Pricing*

Road pricing is an access regulation that usually affects not only freight transport, but all transport, although the prices might discriminate between passenger and freight transportation. Depending on the primary function of the road pricing, the price may increase for different times in a day

or depending on how “clean” the vehicle is. Note that this not a restriction *per se*, but falls more under traffic management schemes.

#### *Parking and Unloading Restrictions*

Finally, parking and unloading restrictions regulate the locations in an area where large vehicles are allowed to park in order to unload deliveries or load pickups. Parking restrictions on *other road users* might also be used to facilitate the loading and unloading activities of freight vehicles on a particular street at a particular time.

#### **Vehicle Technology**

A key aspect of the transport system is the vehicle! A vehicle can be understood in a broader sense than just a machine running on the road carrying your freight. It also extends to non-mechanical means, like walking, or to continuous distribution systems, like pipelines. In this video, we will focus on the most common considerations for deciding between vehicle types from the point of view of freight carriers.



One or more interactive elements has been excluded from this version of the text. You can view them online here: <https://uta.pressbooks.pub/sustainablemobility/?p=388#oembed-2>

#### **Consolidation and Transshipment of Freight**

The subject of **consolidation** and **transshipment** is a regular topic in logistics management, because of the possibility to increase the utilization and efficiency of resources. Ron introduces the topic of urban consolidation centers and the main advantages and disadvantages to the solution in the video below.



One or more interactive elements has been excluded from this version of the text. You can view them online here: <https://uta.pressbooks.pub/sustainablemobility/?p=388#oembed-3>

#### **Shared Logistics**

An important approach to deal with inefficiencies in the urban freight system is for companies to cooperate more with each other. Here, we restrict the discussion to **horizontal logistics** cooperation, rather than vertical logistics cooperation (such as integration along the **supply chain** or subcontracting).

In urban freight, we can identify three types of objects shared among cooperating companies:

- Order sharing

- Capacity sharing
- Information sharing.

In order sharing, “collaborating carriers combine, share or exchange customers orders or requests” for the purpose of optimizing their own transport capabilities and while as a whole, still provide the same level of service. An acceptable and fair method for allocating the costs and revenue according to the service provided by each company needs to be designed.

While in the former type, the transport demand is shared; in capacity sharing, it is the transport supply, which is shared. In other words, there is a temporary loan or borrowing of transport capacity, either in terms of load units (e.g. containers), transport units (e.g. vehicles or drivers), or logistics facilities (e.g. consolidation centres or cross-docks), or also of storage capacity, in terms primarily of warehousing space.

The third type, information sharing, occurs when carriers share information (often anonymized or aggregated to protect legal and business interests) with other partners to improve overall efficiency of operations. Such sharing might need a trusted third-party to collect, aggregate and process the data from the partners. The information could be used, for example, to optimize parking management at a busy street or a loading bay, such that competing carriers do not arrive at the same time.

## EVALUATION OF CITY LOGISTICS

In this video, Prof Taniguchi starts the series of lectures on evaluation of city logistics. Based on the a brief overview of the basic goals of city logistics, this video introduces three categories of city logistics policies with many examples.



One or more interactive elements has been excluded from this version of the text. You can view them online here: <https://uta.pressbooks.pub/sustainablemobility/?p=388#oembed-4>

### Criteria for Evaluation

On what basis are evaluations made? Assistant Professor Ali presents here the typical evaluation criteria used in city logistics, such as cost, environment, social and congestion. It also describes some detailed components, normally, considered under each evaluation criteria.



One or more interactive elements has been excluded from this version of the text. You can view them online here: <https://uta.pressbooks.pub/sustainablemobility/?p=388#oembed-5>

### Modeling of Urban Freight Flows

For many of the tasks in developing, evaluating and implementing sustainable urban freight concepts,

we need to be able to model the freight flows. Freight traffic is embedded in a multi-layered economic and social context. Prof Tavasszy explains, in this video, the state-of-the-art models used in urban freight.



One or more interactive elements has been excluded from this version of the text. You can view them online here: <https://uta.pressbooks.pub/sustainablemobility/?p=388#oembed-6>

## Key Takeaways

- Urban freight movement creates negative impacts, such as air and noise pollution, traffic accidents, congestion, and the emissions of greenhouse gases.
- A sustainable urban freight system balances the four key aspects (a) logistics service quality (b) general condition of the transport system (c) environmental concerns and impacts, and (d) social concerns
- An urban distribution system has three key dimensions (a) Stakeholders – administrators, residents, carriers, shippers, and receivers, (b) Spatial- site, link, regional, city, (c) Factors – financial, social, economic, environmental.
- There are four main approaches to improving the city logistics (a) creation of public/ private infrastructure (b) land use management (c) access conditions (d) traffic management.

## Self-Test



An interactive H5P element has been excluded from this version of the text. You can view it online here: <https://uta.pressbooks.pub/sustainablemobility/?p=388#h5p-9>

## GLOSSARY: KEY TERMS

**Consolidation:** Freight consolidation is when a shipper combines multiple shipments within a region into a single load hauled by a carrier to a destination region.

**Horizontal logistics:** Horizontal logistics cooperation may be defined as “cooperation between two or more firms that are active at the same level of the supply chain and perform a comparable logistics function”. These firms serve the same transport service segment and provide almost the same services. Hence, they are very much rivals, in the fiercely competitive industry.

**Logistics:** logistics refers to the overall process of managing how resources are acquired, stored, and transported to their final destination.

**Shuttle train:** A shuttle train is a train that runs back and forth between two points, especially if it offers a frequent service over a short route.

**Supply chain:** A supply chain is the network of all the individuals, organizations, resources, activities and technology involved in the creation and sale of a product.

**Transshipment:** transshipment is the shipment of goods or containers to an intermediate destination, then to another destination.

**Urban distribution:** Urban freight distribution is the system and process by which goods are collected, transported, and distributed within urban environments. The urban freight system can include seaports, airports, manufacturing facilities, and warehouse/distribution centers that are connected by a network of railroads, rail yards, pipelines, highways, and roadways that enable goods to get to their destinations.

## MEDIA ATTRIBUTIONS

### Figures

- Figure 9.1: A Systems Approach to Urban Distribution from [Sustainable Urban Freight Transport: a Global Perspective](#) by through TU Delft OpenCourseWare is licensed under [Creative Commons Attribution Non-Commercial Share Alike](#)

### Tables

- Table 9.1: Overview of main actions public administrators can perform and potential reactions from the private sector from [Sustainable Urban Freight Transport: A Global Perspective](#) is licensed under a [Creative Commons Attribution-NonCommercial-ShareAlike 4.0 International License](#).

### Videos

- Video 1: [Sustainable Urban Freight: Urban Freight Systems](#) is available for free via <http://www.online-learning.tudelft.nl> © TU Delft, released under a CC BY NC SA license: [https://creativecommons.org/licences/...](https://creativecommons.org/licences/)
- Video 2: [Sustainable Urban Freight: Vehicle Technology](#) is available for free via <http://www.online-learning.tudelft.nl> © TU Delft, released under a CC BY NC SA license: [https://creativecommons.org/licences/...](https://creativecommons.org/licences/)
- Video 3: [Sustainable Urban Freight: Urban Consolidation Centre](#) is available for free via <http://www.online-learning.tudelft.nl> © TU Delft, released under a CC BY NC SA license: [https://creativecommons.org/licences/...](https://creativecommons.org/licences/)
- Video 4: [Sustainable Urban Freight: Evaluating the Impacts of City Logistics Policy Measures](#) is available for free via <http://www.online-learning.tudelft.nl> © TU Delft, released under a CC BY NC SA license: [https://creativecommons.org/licences/...](https://creativecommons.org/licences/)
- Video 5: [Sustainable Urban Freight: Evaluating the Impacts of City Logistics Policy](#)

[Measures](http://www.online-learning.tudelft.nl) is available for free via <http://www.online-learning.tudelft.nl> © TU Delft, released under a CC BY NC SA license: <https://creativecommons.org/licences/...>

- Video 6: [Sustainable Urban Freight: Modelling City Logistics](http://www.online-learning.tudelft.nl) is available for free via <http://www.online-learning.tudelft.nl> © TU Delft, released under a CC BY NC SA license: <https://creativecommons.org/licences/...>

## REFERENCES

- Muñuzuri, J., Larrañeta, J., Onieva, L., & Cortés, P. (2005). Solutions applicable by local administrations for urban logistics improvement. *Cities*. <https://doi.org/10.1016/j.cities.2004.10.003>
- [Sustainable Urban Freight Transport: a Global Perspective](http://www.online-learning.tudelft.nl) by TU Delft OpenCourseWare is licensed under a Creative Commons Attribution-NonCommercial-ShareAlike 4.0 International License.

## ATTRIBUTIONS

- [Transforming the Freight Industry](http://www.accessmagazine.com) in *ACCESS Magazine*, 1(20), 26-31 by Regan, A. is licensed by [CC BY-NC 3.0](https://creativecommons.org/licenses/by-nc/3.0/)
- [Sustainable Urban Freight Transport: a Global Perspective](http://www.online-learning.tudelft.nl) by [Dr. J.H.R. van Duin](http://www.tudelft.nl), [Dr. Johan Joubert](http://www.tudelft.nl), [Dr. Russell Thompson](http://www.tudelft.nl), [Ir. Tharsis Teoh](http://www.tudelft.nl), [Prof.dr.ir. L.A. Tavasszy](http://www.tudelft.nl) through TU Delft OpenCourseWare is licensed under [Creative Commons Attribution Non-Commercial Share Alike](https://creativecommons.org/licenses/by-nc-sa/4.0/)





## LINKS BY CHAPTER

---

### [CHAPTER 1](#)

- Figure 1.1: [Three pillars of sustainability](#) by Neyda Abreu is under the following Creative Commons license: [CC BY-NC-SA 4.0](#)
- Figure 1.2: [World Oil Production- History and Projections](#) by Tom Ruen is under the Public Domain via Wikimedia Commons
- Figure 1.3: [Freeway Traffic by User Minesweeper via Wikimedia Commons](#) is under the following Creative Commons license: [CC-BY-SA-3.0](#)

### [CHAPTER 2](#)

- Figure 2.1: [“Bending the Curve: Climate Change Solutions”](#) by Ramanathan et al. (2019) and reproduced from the Scripps CO2 Program from the Scripps Institution of Oceanography is under the following Creative Commons license: [CC BY-NC-SA 4.0](#)
- Figure 2.2: “Change in Total Greenhouse Gas Emissions from Different Sectors in the United States during 1990- 2023” by Shams Tanvir [using data from the EPA](#) is under the following Creative Commons license: [CC BY-NC-SA 4.0](#)
- Figure 2.3: [“Air pollution emissions yearly trends”](#) by Ramanathan et al. (2019) and adapted from US Environmental Protection Agency 2019 is under the following Creative Commons license: [CC BY-NC-SA 4.0](#)
- Figure 2.4: [“California tailpipe HC performance standards for new light duty vehicle”](#) by Ramanathan et al. (2019) is under the following Creative Commons license: [CC BY-NC-SA 4.0](#)
- Figure 2.5: [“CO<sub>2</sub> emissions, in grams per mile, for a representative database of passenger vehicle trips in Southern California”](#) by Ramanathan et al. (2019) is under the following Creative Commons license: [CC BY-NC-SA 4.0](#)
- Figure 2.6: [“Emission-speed plot of individual trips or trip segments”](#) by Ramanathan et al. (2019) is under the following Creative Commons license: [CC BY-NC-SA 4.0](#)
- Figure 2.7: [“Possible use of traffic operation strategies in reducing on-road CO<sub>2</sub> emissions”](#) by Ramanathan et al. (2019) is under the following Creative Commons license: [CC BY-NC-SA 4.0](#)
- Figure 2.8: [“General approach for calculating GHG emissions from transportation”](#) by Ramanathan et al. (2019) is under the following Creative Commons license: [CC BY-NC-SA 4.0](#)

### CHAPTER 3

- Figure 3.1: [Sharrow on US1 in West Palm Beach](#) by Michael Rivera is under the following Creative Commons license: [CC BY-SA 4.0](#)
- Figure 3.2: [Bike route along California State Highway 35](#) by Robert Ashworth is under the following Creative Commons license: [CC BY 2.0](#)
- Figure 3.3: [Bike lane on Pleasant Valley Parkway, Providence RI](#) by Kenneth C. Zirkel is under the following Creative Commons license: [CC BY-SA 4.0](#)
- Figure 3.4: [Bike route sign with directional information](#) by Richard Drdul is under the following Creative Commons license: [CC BY-SA 2.0](#)
- Figure 3.5: [Pandora cycle track 4](#) by Richard Drdul is under the following Creative Commons license: [CC BY-SA 2.0](#)
- Figure 3.6: [Protected intersection features](#) by Pierre Rouzeau via Wikimedia Commons is under the following Creative Commons license: [CC BY-SA 4.0](#)

### CHAPTER 4

- NA

### CHAPTER 5

#### Figures

- Figure 5.1: [Bending the Curve: Climate Change Solutions](#) by Ramanathan, V., Aines, R., Auffhammer, M., Barth, M., Cole, J., Forman, F., et al. is licensed under [CC BY-NC-SA 4.0](#)
- Figure 5.2: [Average passenger car GHG emissions normalized by distance traveled for different regions](#) by Ramanathan et al. (2019) is licensed under [CC BY-NC-SA 4.0](#)
- Figure 5.3: [The number of electric vehicles \(EVs\) being introduced for different regions](#) is licensed under [CC BY-NC-SA 4.0](#)
- Figure 5.4: [Fuel utilization for the US transportation market, 2018](#) is licensed under [CC BY-NC-SA 4.0](#)
- Figure 5.5: Modules of integrated traffic simulation and emission estimation. Produced with permission from the author Tanvir (2018).

#### Tables

- Table 5.1: [Greenhouse Gas Emissions per Kilometer, relative to Gasoline-Powered Internal Combustion Engines, Full Energy Cycle](#) by Ramanathan, V., Aines, R., Auffhammer, M., Barth, M., Cole, J., Forman, F., et al. is licensed under [CC BY-NC-SA 4.0](#)

### CHAPTER 6

- Figure 6.1: Los Angeles 1943: Degraded Urban Air Quality by Ramanathan et al is under the following Creative Commons license: [CC BY-NC-SA 4.0](#)

- Figure 6.2: Combustion by Ramanathan is under the following Creative Commons license: [CC BY-NC-SA 4.0](#)
- Figure 6.3: Combustion Impacts by Ramanathan et al is under the following Creative Commons license: [CC BY-NC-SA 4.0](#)
- Figure 6.4: Power Generation Options by Ramanathan is under the following Creative Commons license: [CC BY-NC-SA 4.0](#)
- Figure 6.5: Greenhouse Gas Emissions by Sector for 2016 by Analy Casillo is under the following Creative Commons license: [CC BY-NC-SA 4.0](#)
- Figure 6.6: Greenhouse Gas Emissions for the Transportation Sector in California by Analy Casillo is under the following Creative Commons license: [CC BY-NC-SA 4.0](#)

## CHAPTER 7

### Figures

- Figure 7.1: [Conductive Charging- AC by Electric Cars: Technology](#) is licensed under [CC BY-NC-SA 4.0](#)
- Figure 7.2: [Conductive Charging- DC by Electric Cars: Technology](#) is licensed under [CC BY-NC-SA 4.0](#)
- Figure 7.3: [Inductive Charging- Static by Electric Cars: Technology](#) is licensed under [CC BY-NC-SA 4.0](#)
- Figure 7.4: [Inductive Charging- Dynamic by Electric Cars: Technology](#) is licensed under [CC BY-NC-SA 4.0](#)
- Figure 7.5: [AC Charging Operations by Electric Cars: Technology](#) is licensed under [CC BY-NC-SA 4.0](#)

### Tables

- [Table 7.1](#) is licensed under [CC BY-NC-SA 4.0](#)
- [Table 7.2: Summary of Common Level 1 to Level 4 Charging Facilities in North America](#) is licensed under [CC BY 4.0](#)

### Videos

- Video 1: [Introduction to Charging Methods of EVs](#) is available for free via <http://www.online-learning.tudelft.nl> © TU Delft, released under a CC BY NC SA license: <https://creativecommons.org/licences/...>
- Video 2: [AC Charging of EVs](#) is available for free via <http://www.online-learning.tudelft.nl> © TU Delft, released under a CC BY NC SA license: <https://creativecommons.org/licences/...>
- Video 3: [DC Charging of EVs](#) is available for free via <http://www.online-learning.tudelft.nl> © TU Delft, released under a CC BY NC SA license: <https://creativecommons.org/licences/...>
- Video 4: [Smart Charging and V2G](#) is available for free via <http://www.online-learning.tudelft.nl> © TU Delft, released under a CC BY NC SA license:

<https://creativecommons.org/licences/...>

- Video 5: [Charging of Electric Vehicles ICT Aspects of Electric Charging](#) is available for free via <http://www.online-learning.tudelft.nl> © TU Delft, released under a CC BY NC SA license: <https://creativecommons.org/licences/...>
- Video 6: [Case Study ABB](#) is available for free via <http://www.online-learning.tudelft.nl> © TU Delft, released under a CC BY NC SA license: <https://creativecommons.org/licence>

## [CHAPTER 8](#)

### Figures

- Figure 8.1: Potential energy/emissions impacts of automated technology from [“Bending the Curve: Climate Change Solutions”](#) by Ramanathan et al. is under the following Creative Commons license: [CC BY-NC-SA 4.0](#)

### Tables

- Table 8.1: Intelligent transportation system applications utilizing connected and automated vehicle technology from [“Bending the Curve: Climate Change Solutions”](#) by Ramanathan et al. is under the following Creative Commons license: [CC BY-NC-SA 4.0](#)

## [CHAPTER 9](#)

### Figures

- Figure 9.1: A Systems Approach to Urban Distribution from [Sustainable Urban Freight Transport: a Global Perspective](#) by through TU Delft OpenCourseWare is licensed under [Creative Commons Attribution Non-Commercial Share Alike](#)

### Tables

- Table 9.1: Overview of main actions public administrators can perform and potential reactions from the private sector from [Sustainable Urban Freight Transport: A Global Perspective](#) is licensed under a [Creative Commons Attribution-NonCommercial-ShareAlike 4.0 International License](#).

### Videos

- Video 1: [Sustainable Urban Freight: Urban Freight Systems](#) is available for free via <http://www.online-learning.tudelft.nl> © TU Delft, released under a CC BY NC SA license: <https://creativecommons.org/licences/...>
- Video 2: [Sustainable Urban Freight: Vehicle Technology](#) is available for free via <http://www.online-learning.tudelft.nl> © TU Delft, released under a CC BY NC SA license: <https://creativecommons.org/licences/...>
- Video 3: [Sustainable Urban Freight: Urban Consolidation Centre](#) is available for free via <http://www.online-learning.tudelft.nl> © TU Delft, released under a CC BY NC SA license: <https://creativecommons.org/licences/...>

- Video 4: [Sustainable Urban Freight: Evaluating the Impacts of City Logistics Policy Measures](#) is available for free via <http://www.online-learning.tudelft.nl> © TU Delft, released under a CC BY NC SA license: <https://creativecommons.org/licences/...>
- Video 5: [Sustainable Urban Freight: Evaluating the Impacts of City Logistics Policy Measures](#) is available for free via <http://www.online-learning.tudelft.nl> © TU Delft, released under a CC BY NC SA license: <https://creativecommons.org/licences/...>
- Video 6: [Sustainable Urban Freight: Modelling City Logistics](#) is available for free via <http://www.online-learning.tudelft.nl> © TU Delft, released under a CC BY NC SA license: <https://creativecommons.org/licences/...>

## REFERENCES

---

### CHAPTER 1

- Report of the World Commission on Environment and Development: Our Common Future. 1987. [www.un-documents.net/wced-ocf.htm](http://www.un-documents.net/wced-ocf.htm).
- Appleyard, B. S. 2005. Livable Streets for School Children: How Safe Routes to School programs can improve street and community livability for children. National Centre for Bicycling and Walking Forum, available online: <http://www.bikewalk.org/pdfs/forumarch0305.pdf>
- Banister, D. and Berechman, Y. 2001. Transport investment and the promotion of economic growth. *Journal of Transport Geography* 9:3, 209-218.
- Black, W. 2010. Sustainable Transportation: Problems and Solutions. New York: Guilford Press.
- Deffeyes, K. 2002. Hubbert's Peak: The Impending World Oil Shortage. Princeton, NJ: Princeton University Press.
- DOE (Department of Energy). 2009. Emissions of greenhouse gases report. DOE/EIA-0573, available online: <http://www.eia.doe.gov/oiaf/1605/ggrpt/carbon.html>
- Downs, A. 1992. Stuck in Traffic: Coping With Peak-Hour Traffic Congestion. Washington, DC: Brookings Institution Press.
- IMF (International Monetary Fund). 2010. Impact of high food and fuel prices on developing countries. Available online: <http://www.imf.org/external/np/exr/faq/ffpfaqs.htm>
- Maring, G. 2007. Surface transportation funding issues and options. Presentation to the National Surface Transportation Infrastructure Financing Commission. Available online: [http://financecommission.dot.gov/Documents/Surface%20Transportation%20Funding%20Issues%20and%20Options\\_Gary%20Maring.ppt](http://financecommission.dot.gov/Documents/Surface%20Transportation%20Funding%20Issues%20and%20Options_Gary%20Maring.ppt)
- Marsh, B. 2011. Kilowatts vs. Gallons. *New York Times*, May 28. Available online: <http://www.nytimes.com/interactive/2011/05/29/weekinreview/volt-graphic.html?ref=weekinreview>
- UPI (United Press International). 2011. Global biofuel land area estimated. Available online: [http://www.upi.com/Science\\_News/2011/01/10/Global-biofuel-land-area-estimated/UPI-97301294707088/](http://www.upi.com/Science_News/2011/01/10/Global-biofuel-land-area-estimated/UPI-97301294707088/)
- Urry, J., 2004. The 'System' of Automobility. *Theory Culture and Society* 21:4-5, 25-39.
- Usón, A.A., Capilla, A.V., Bribián, I.Z., Scarpellini, S. and Sastresa, E.L. 2011. Energy efficiency in transport and mobility for an eco-efficiency viewpoint. *Energy* 36:4, 1916-23.

- Xu, J., Kochanek, K., Murphy, S., and Tejada-Vera, B. 2010. Deaths: Final Data for 2007. National Vital Statistics Reports, 58:19, available online: [http://www.cdc.gov/NCHS/data/nvsr/nvsr58/nvsr58\\_19.pdf](http://www.cdc.gov/NCHS/data/nvsr/nvsr58/nvsr58_19.pdf)

## CHAPTER 2

- [Transportation system resilience to extreme weather and climate change](#). FHWA-HOP-15-025. November 2015. Pursuant to Title 17 Section 105 of the United States Code, this file is not subject to copyright protection and is in the public domain. [Copyright information](#).

## CHAPTER 3

- California Department of Transportation (Caltrans). (2020). *Chapter 1000:– Bicycle Transportation Design, Highway Design Manual*. Sacramento, CA.
- National Association of City Transportation Officials (NACTO).
- National Academies of Sciences, Engineering, and Medicine. (2022). *Highway capacity manual 7th edition: A guide for multimodal mobility analysis*.
- AASHTO Task Force on Geometric Design (1999). *AASHTO Guide for the Development of Bicycle Facilities*. American Association of State Highway and Transportation Officials, Washington, DC.

## CHAPTER 4

- Transportation Officials. (2004). [Guide for the planning, design, and operation of pedestrian facilities](#). AASHTO.

## CHAPTER 5

- Ramanathan, V., Aines, R., Auffhammer, M., Barth, M., Cole, J., Forman, F., et al. (2019). *Bending the Curve: Climate Change Solutions*. Location: Regents of the University of California. Editor: V. Ramanathan. Co-Editors: Adam Millard-Ball; Michelle Niemann; Scott Friese. Book published by the Regents of the Univ of California. Retrieved from <https://escholarship.org/uc/item/6kr8p5rq>. 815pp <https://creativecommons.org/licenses/by-nc-sa/4.0/>
- Tanvir, Shams. *Modeling and Simulation of Driving Activity from an Energy Use-Emissions Perspective*. North Carolina State University, 2018.
- Ahn, K., Rakha, H., Trani, A., & Van Aerde, M. (2002). Estimating vehicle fuel consumption and emissions based on instantaneous speed and acceleration levels. *Journal of Transportation Engineering*, 128(2), 182-190.
- Alkidas, A. C. (2007). Combustion advancements in gasoline engines. *Energy Conversion and Management*, 48(11), 2751-2761.
- An, F., Barth, M., Norbeck, J., & Ross, M. (1997). Development of comprehensive modal emissions model: Operating under hot-stabilized conditions. *Transportation Research Record: Journal of the Transportation Research Board*, 1587(1), 52-62.

- Barth, M., & Boriboonsomsin, K. (2009). Traffic congestion and greenhouse gases. *ACCESS Magazine*, 1(35)
- Bartin, B., Mudigonda, S., & Ozbay, K. (2007). Impact of electronic toll collection on air pollution levels: Estimation using microscopic simulation model of large-scale transportation network. *Transportation Research Record: Journal of the Transportation Research Board*, 2011(1), 68-77.
- BTS. (2015). *State transportation statistics 2015*. Washington DC: US Department of Transportation, Bureau of Transportation Statistics.
- Bureau of Transportation Statistics. (2013). National transportation statistics (table 1-11: Number of U.S. aircraft, vehicles, vessels, and other conveyances). Retrieved from [http://www.bts.gov/publications/national\\_transportation\\_statistics/html/table\\_01\\_11.html](http://www.bts.gov/publications/national_transportation_statistics/html/table_01_11.html)
- Cambridge Systematics. (1996). *Quantifying air quality and other benefits and costs of transportation control measures*. ( No. Task 1 Report. Project 8-33.). Washington D.C: National Cooperative Highway Research, Transportation Research Board.
- Cappiello, A. (2002). *Modeling traffic flow emissions* (MS Thesis).
- CARB. (2002). *EMFAC 2002, california air resources board's emission inventory* . ( No. Series, September).California Air Resource Board.
- Chamberlin, R., Swanson, B., Talbot, E., Dumont, J., & Pesci, S. (2011). Analysis of MOVES and CMEM for evaluating the emissions impact of an intersection control change. Paper presented at the *Transportation Research Board 90th Annual Meeting*, (11-0673)
- Daganzo, C. F. (2006). In traffic flow, cellular automata = kinematic waves. *Transportation Research Part B: Methodological*, 40(5), 396-403. doi://[dx.doi.org/prox.lib.ncsu.edu/10.1016/j.trb.2005.05.004](http://dx.doi.org/prox.lib.ncsu.edu/10.1016/j.trb.2005.05.004)
- De Vlieger, I., De Keukeleere, D., & Kretzschmar, J. G. (2000). Environmental effects of driving behaviour and congestion related to passenger cars. *Atmospheric Environment*, 34(27), 4649-4655.
- Eliasson, J., Hultkrantz, L., Nerhagen, L., & Rosqvist, L. S. (2009). The stockholm congestion–charging trial 2006: Overview of effects. *Transportation Research Part A: Policy and Practice*, 43(3), 240-250.
- EPA. (1999). *Regulatory announcements*. Ann Arbor, MI: United States Environmental Protection Agency.
- EPA. (2008). *Integrated science assessment for oxides of nitrogen – health criteria (final report)*. ( No. EPA/600/R-08/071). Washington D.C.: U.S. Environmental Protection Agency.
- EPA. (2010). *Integrated science assessment for carbon monoxide (final report)*. ( No. EPA/600/R-09/019F). Washington D.C.: U.S. Environmental Protection Agency.
- EPA. (2012). *User guide for MOVES2010b*. ( No. EPA-420-B-12-001b).United State Environmental Protection Agency.
- EPA. (2014). *Inventory of U.S. greenhouse gas emissions and sinks: 1990-2012*. ( No. EPA 430-R-14-003). Washington D.C.: U.S. EPA.



- Etheridge, D. M., Steele, L. P., Langenfelds, R. L., Francey, R. J., Barnola, J., & Morgan, V. I. (1996). Natural and anthropogenic changes in atmospheric CO<sub>2</sub> over the last 1000 years from air in antarctic ice and firn. *Journal of Geophysical Research: Atmospheres (1984–2012)*, 101(D2), 4115-4128.
- Faiz, A., Weaver, C. S., & Walsh, M. P. (1996). *Air pollution from motor vehicles: Standards and technologies for controlling emissions* World Bank-free PDF.
- Frey, H. C., Zhai, H., & Roupail, N. M. (2009). Regional on-road vehicle running emissions modeling and evaluation for conventional and alternative vehicle technologies. *Environmental Science & Technology*, 43(21), 8449-8455. doi:10.1021/es900535s; 10.1021/es900535s
- Frey, H. C., & Liu, B. (2014). Development and evaluation of a simplified version of MOVES for coupling with a traffic simulation model. *Proceedings, 91st Annual Meeting of the Transportation Research Board*,
- Frey, H. C., Roupail, N. M., Unal, A., & Colyar, J. D. (2001). No title. *Emissions Reduction through Better Traffic Management: An Empirical Evaluation Based upon on-Road Measurements*,
- Frey, H. C., Yazdani-Boroujeni, B., Hu, J., Liu, B., & Jiao, W. (2013). Field measurements of 1996 to 2013 model year light duty gasoline vehicles. Paper presented at the *Proceedings, 106th Annual Conference, Air & Waste Management Association, Chicago, IL*,
- Fujita, E. M., Campbell, D. E., Zielinska, B., Chow, J. C., Lindhjem, C. E., DenBleyker, A., . . . Lawson, D. R. (2012). Comparison of the MOVES2010a, MOBILE6. 2, and EMFAC2007 mobile source emission models with on-road traffic tunnel and remote sensing measurements. *Journal of the Air & Waste Management Association*, 62(10), 1134-1149.
- Gordon, P., Kumar, A., & Richardson, H. W. (1990). Peak-spreading: How much? *Transportation Research Part A: General*, 24(3), 165-175.
- Greene, D. L., & Plotkin, S. E. (2011). Reducing greenhouse gas emission from US transportation. *Arlington: Pew Center on Global Climate Change*,
- Gualtieri, G., & Tartaglia, M. (1998). Predicting urban traffic air pollution: A GIS framework. *Transportation Research Part D: Transport and Environment*, 3(5), 329-336.
- Health Effects Institute. Panel on the Health Effects of Traffic-Related Air Pollution. (2010). *Traffic-related air pollution: A critical review of the literature on emissions, exposure, and health effects* Health Effects Institute.
- Hurdle, V. F., & Son, B. (2000). Road test of a freeway model. *Transportation Research Part A: Policy and Practice*, 34(7), 537-564. doi://[dx.doi.org/prox.lib.ncsu.edu/10.1016/S0965-8564\(99\)00031-2](https://dx.doi.org/prox.lib.ncsu.edu/10.1016/S0965-8564(99)00031-2)
- Jimenez-Palacios, J. L. (1998). *Understanding and quantifying motor vehicle emissions with vehicle specific power and TILDAS remote sensing*
- Karppinen, A., Kukkonen, J., Elolähde, T., Konttinen, M., Koskentalo, T., & Rantakrans, E. (2000). A modelling system for predicting urban air pollution: Model description and applications in the helsinki metropolitan area. *Atmospheric Environment*, 34(22), 3723-3733.
- Koupal, J., Cumberworth, M., Michaels, H., Beardsley, M., & Brzezinski, D. (2002). Design and

implementation of MOVES: EPA's new generation mobile source emission model. *Ann Arbor, 1001*, 48105.

- Koupal, J., Michaels, H., Cumberworth, M., Bailey, C., & Brzezinski, D. (2002). (2002). EPA's plan for MOVES: A comprehensive mobile source emissions model. Paper presented at the *Proceedings of the 12th CRC on-Road Vehicle Emissions Workshop, San Diego, CA*,
- Krzyzanowski, M., Kuna-Dibbert, B., & Schneider, J. (2005). *Health effects of transport-related air pollution* World Health Organization Copenhagen.
- Lautso, K., & Toivanen, S. (1999). SPARTACUS system for analyzing urban sustainability. *Transportation Research Record: Journal of the Transportation Research Board*, 1670(1), 35-46.
- Ligterink, N. E., & Lange, R. d. (2009). Refined vehicle and driving-behaviour dependencies in the VERSIT emission model. Paper presented at the *ETAPP Symposium*,
- Lin, J., Chiu, Y., Vallamsundar, S., & Bai, S. (2011a). Integration of MOVES and dynamic traffic assignment models for fine-grained transportation and air quality analyses. Paper presented at the *Integrated and Sustainable Transportation System (FISTS), 2011 IEEE Forum On*, 176-181.
- Lin, J., Chiu, Y., Vallamsundar, S., & Bai, S. (2011b). Integration of MOVES and dynamic traffic assignment models for fine-grained transportation and air quality analyses. Paper presented at the *Integrated and Sustainable Transportation System (FISTS), 2011 IEEE Forum On*, 176-181.
- Lomax, T., Turner, S., Shunk, G., Levinson, H. S., Pratt, R. H., Bay, P. N., & Douglas, G. B. (1997). NCHRP report 398: Quantifying congestion. *Transportation Research Board, National Research Council, Washington, DC*,
- Mahmassani, H. S., & Liu, Y. (1999). Dynamics of commuting decision behaviour under advanced traveller information systems. *Transportation Research Part C: Emerging Technologies*, 7(2), 91-107.
- Meyer, M. D. (1999). Demand management as an element of transportation policy: Using carrots and sticks to influence travel behavior. *Transportation Research Part A: Policy and Practice*, 33(7), 575-599.
- Mitchell, G., Namdeo, A., Lockyer, J., & May, A. D. (2002). The impact of road pricing and other strategic road transport initiatives on urban air quality. Paper presented at the *Proceedings of the 8th International Conference on Urban Transport and the Environment in the 21st Century*, 481-490.
- Nam, E. K., Brazil, H., & Sutulo, S. (2002) The integration of a fuel rate based modal emissions model (CMEM modified) into the VISSIM microscopic traffic model – inventory comparison with MOBILE6 in southfield michigan. . *Proceedings of the 12th CRC on-Road Vehicle Emissions Workshop*,
- Namdeo, A., Mitchell, G., & Dixon, R. (2002). TEMMS: An integrated package for modelling and mapping urban traffic emissions and air quality. *Environmental Modelling & Software*, 17(2), 177-188.
- Newell, G. F. (1993). A simplified theory of kinematic waves in highway traffic: (I) general theory; (ii) queuing at freeway bottlenecks; (iii) multi-dimensional flows . *Transportation Research Part B: Methodological*, 27(4), 281-313.

- Newell, G. F. (2002). A simplified car-following theory: A lower order model. *Transportation Research Part B: Methodological*, 36(3), 195-205.
- Ni, D., Leonard, J. D., & Williams, B. M. (2006). The network kinematic waves model: A simplified approach to network traffic. *Journal of Intelligent Transportation Systems*, 10(1), 1-14.
- Noland, R. B., & Quddus, M. A. (2006). Flow improvements and vehicle emissions: Effects of trip generation and emission control technology. *Transportation Research Part D: Transport and Environment*, 11(1), 1-14.
- Ntziachristos, L., Samaras, Z., Eggleston, S., Gorissen, N., Hassel, D., & Hickman, A. J. (2000). Copert iii. *Computer Programme to Calculate Emissions from Road Transport, Methodology and Emission Factors (Version 2.1)*, European Energy Agency (EEA), Copenhagen,
- Oduyemi, K., & Davidson, B. (1998). The impacts of road traffic management on urban air quality. *Science of the Total Environment*, 218(1), 59-66.
- Roughgarden, T. (2012). The price of anarchy in games of incomplete information. Paper presented at the *Proceedings of the 13th ACM Conference on Electronic Commerce*, 862-879.
- Samaranayake, S., Glaser, S., Holstius, D., Monteil, J., Tracton, K., Seto, E., & Bayen, A. (2014). Real-Time estimation of pollution emissions and dispersion from highway traffic. *Computer-Aided Civil and Infrastructure Engineering*, 29(7), 546-558.
- Schrank, D. L., & Lomax, T. J. (2007). *The 2007 urban mobility report* Texas Transportation Institute, Texas A & M University.
- Schrank, D., Eisele, B., Lomax, T., & Bak, J. (2015). *2015 urban mobility scorecard*. Texas: Texas A&M Transportation Institute and INRIX, Inc.
- Sivak, M., & Schoettle, B. (2012). Eco-driving: Strategic, tactical, and operational decisions of the driver that influence vehicle fuel economy. *Transport Policy*, 22, 96-99.
- Sjodin, A., Persson, K., Andreasson, K., Arlander, B., & Galle, B. (1998). On-road emission factors derived from measurements in a traffic tunnel. *International Journal of Vehicle Design*, 20(1), 147-158.
- Smit, R. (2006). *An examination of congestion in road traffic emission models and their application to urban road networks*
- Song, G., Yu, L., & Zhang, Y. (2012). Applicability of traffic microsimulation models in vehicle emissions estimates. *Transportation Research Record: Journal of the Transportation Research Board*, 2270(1), 132-141.
- Stathopoulos, F. G., & Noland, R. B. (2003). Induced travel and emissions from traffic flow improvement projects. *Transportation Research Record: Journal of the Transportation Research Board*, 1842(1), 57-63.
- Tanvir, S., Karmakar, N., Roupail, N. M., & Schroeder, B. J. (2016). Modeling freeway work zones with mesoscopic dynamic traffic simulator: Validation, gaps, and guidance. *Transportation Research Record: Journal of the Transportation Research Board*, (2567), 122-130.
- Tonne, C., Beevers, S., Armstrong, B., Kelly, F., & Wilkinson, P. (2008). Air pollution and mortality benefits of the london congestion charge: Spatial and socioeconomic inequalities.

*Occupational and Environmental Medicine*, 65(9), 620-627.

- Twigg, M. V. (2007). Progress and future challenges in controlling automotive exhaust gas emissions. *Applied Catalysis B: Environmental*, 70(1), 2-15.
- USEPA. (2007). *MOBILE 6 vehicle emission modelling software and documentation*. (). Washington, DC: US Environmental Protection Agency.
- Vallamsundar, S., & Lin, J. (. (2011). MOVES versus MOBILE. *Transportation Research Record: Journal of the Transportation Research Board*, 2233(1), 27-35.
- Xie, Y., Chowdhury, M. A., Bhavsar, P., & Zhou, Y. (2011). An integrated tool for modeling the impact of alternative fueled vehicles on traffic emissions: A case study of greenville, south carolina. Paper presented at the *Transportation Research Board 90th Annual Meeting*, (11-3880)
- Yperman, I. (2007). *The link transmission model for dynamic network loading* (Ph.D. Thesis).
- Zhai, H., Frey, H. C., Roupail, N. M., Goncalves, G. A., & Farias, T. L. (2009). Comparison of flexible fuel vehicle and life-cycle fuel consumption and emissions of selected pollutants and greenhouse gases for ethanol 85 versus gasoline. *Journal of the Air & Waste Management Association (1995)*, 59(8), 912-924.
- Zhang, K., & Batterman, S. A. (2009). Time allocation shifts and pollutant exposure due to traffic congestion: An analysis using the national human activity pattern survey. *Science of the Total Environment*, 407(21), 5493-5500.
- Zhou, X., Tanvir, S., Lei, H., Taylor, J., Liu, B., Roupail, N. M., & Christopher Frey, H. (2015). Integrating a simplified emission estimation model and mesoscopic dynamic traffic simulator to efficiently evaluate emission impacts of traffic management strategies. *Transportation Research Part D: Transport and Environment*, 37, 123-136. doi://[dx.doi.org/10.1016/j.trd.2015.04.013](https://doi.org/10.1016/j.trd.2015.04.013)

## CHAPTER 6

- [Bending the Curve: Climate Change Solutions](#) by Ramanathan, V., Aines, R., Auffhammer, M., Barth, M., Cole, J., Forman, F., et al. is licensed by the following creative commons license: [CC BY-NC-SA 4.0](#)

## CHAPTER 7

- [Bending the Curve: Climate Change Solutions](#) by Ramanathan, V., Aines, R., Auffhammer, M., Barth, M., Cole, J., Forman, F., et al. is licensed by the following creative commons license: [CC BY-NC-SA 4.0](#)

## CHAPTER 8

- Greenblatt, J. B., & Shaheen, S. (2015). Automated vehicles, on-demand mobility, and environmental impacts. *Current sustainable/renewable energy reports*, 2(3), 74-81.
- Walker, J., & Johnson, C. (2016). Peak car ownership: The market opportunity of electric automated mobility services. *Rocky Mountain Institute*.
- SAE international. (2016). Taxonomy and definitions for terms related to driving automation

systems for on-road motor vehicles. *SAE International*,(J3016).

- Hu, L., Dong, J., Lin, Z., & Yang, J. (2018). Analyzing battery electric vehicle feasibility from taxi travel patterns: The case study of New York City, USA. *Transportation Research Part C: Emerging Technologies*, 87, 91-104.
- Alonso-Mora, J., Samaranayake, S., Wallar, A., Frazzoli, E., & Rus, D. (2017). On-demand high-capacity ride-sharing via dynamic trip-vehicle assignment. *Proceedings of the National Academy of Sciences*, 114(3), 462-467.
- Bischoff, J., & Maciejewski, M. (2016). Simulation of city-wide replacement of private cars with autonomous taxis in Berlin. *Procedia computer science*, 83, 237-244.
- Wenzel, T., Rames, C., Kontou, E., & Henao, A. (2019). Travel and energy implications of ridesourcing service in Austin, Texas. *Transportation Research Part D: Transport and Environment*, 70, 18-34.
- Komanduri, A., Wafa, Z., Proussaloglou, K., & Jacobs, S. (2018). Assessing the impact of app-based ride share systems in an urban context: Findings from Austin. *Transportation Research Record*, 2672(7), 34-46.
- Castiglione, J., Cooper, D., Sana, B., Tischler, D., Chang, T., Erhardt, G., Roy, S., Chen, M., & Mucci, A. (2018, October). TNCs & congestion. Draft report, San Francisco County Transportation Authority.
- Castillo, J. C., Knoepfle, D., & Weyl, G. (2017, June). Surge pricing solves the wild goose chase. In *Proceedings of the 2017 ACM Conference on Economics and Computation* (pp. 241-242). ACM.
- Schaller, B. (2018). Making Congestion Pricing Work for Traffic and Transit in New York City. *Schaller Consulting*.
- Xu, Z., Yin, Y., & Ye, J. (2019). On the supply curve of ride-hailing systems. *Transportation Research Part B: Methodological*.
- Hall, J. D., Palsson, C., & Price, J. (2018). Is Uber a substitute or complement for public transit?. *Journal of Urban Economics*, 108, 36-50.
- Henao, A., & Marshall, W. E. (2018). The impact of ride-hailing on vehicle miles traveled. *Transportation*, 1-22.
- Bauer, G. S., Greenblatt, J. B., & Gerke, B. F. (2018). Cost, energy, and environmental impact of automated electric taxi fleets in Manhattan. *Environmental science & technology*, 52(8), 4920-4928.
- Wadud, Z., MacKenzie, D., & Leiby, P. (2016). Help or hindrance? The travel, energy and carbon impacts of highly automated vehicles. *Transportation Research Part A: Policy and Practice*, 86, 1-18.
- Meyer, J., Becker, H., Bösch, P. M., & Axhausen, K. W. (2017). Autonomous vehicles: The next jump in accessibilities?. *Research in Transportation Economics*, 62, 80-91.
- Ramanathan, V., Aines, R., Auffhammer, M., Barth, M., Cole, J., Forman, F., et al. (2019). *Bending the Curve: Climate Change Solutions*. Location: Regents of the University of California. Editor: V. Ramanathan. Co-Editors: Adam Millard-Ball; Michelle Niemann; Scott

Friese. Book published by the Regents of the Univ of California. Retrieved from <https://escholarship.org/uc/item/6kr8p5rq>. 815pp. <https://creativecommons.org/licenses/by-nc-sa/4.0/>

## CHAPTER 9

- [Sustainable Urban Freight Transport: a Global Perspective](#) by TU Delft OpenCourseWare is licensed under a Creative Commons Attribution-NonCommercial-ShareAlike 4.0 International License.

## IMAGE CREDITS

---

This work contains copyrighted material the use of which has not always been specifically authorized by the copyright owners. The creators of this OER believe in good faith that reuse of these materials constitutes a “fair use” as described in [Section 107 of the Copyright Act](#). Downstream users who wish to use copyrighted material from this resource for purposes beyond those authorized by the fair use doctrine should obtain permission from the copyright owner(s) of the original content.

Unless noted below, all figures used in the text are the intellectual property of the content creators and are licensed under a [Creative Commons Attribution 4.0 International](#) license.

### CHAPTER 1

- Figure 1.1: [Three pillars of sustainability](#) by Neyda Abreu is under the following Creative Commons license: [CC BY-NC-SA 4.0](#)
- Figure 1.2: [World Oil Production- History and Projections](#) by Tom Ruen is under the Public Domain via Wikimedia Commons
- Figure 1.3: [Freeway Traffic by User Minesweeper via Wikimedia Commons](#) is under the following Creative Commons license: [CC-BY-SA-3.0](#)

### CHAPTER 2

- Figure 2.1: [“Bending the Curve: Climate Change Solutions”](#) by Ramanathan et al. (2019) and reproduced from the Scripps CO2 Program from the Scripps Institution of Oceanography is under the following Creative Commons license: [CC BY-NC-SA 4.0](#)
- Figure 2.2: “Change in Total Greenhouse Gas Emissions from Different Sectors in the United States during 1990- 2023” by Shams Tanvir [using data from the EPA](#) is under the following Creative Commons license: [CC BY-NC-SA 4.0](#)
- Figure 2.3: [“Air pollution emissions yearly trends”](#) by Ramanathan et al. (2019) and adapted from US Environmental Protection Agency 2019 is under the following Creative Commons license: [CC BY-NC-SA 4.0](#)
- Figure 2.4: [“California tailpipe HC performance standards for new light duty vehicle”](#) by Ramanathan et al. (2019) is under the following Creative Commons license: [CC BY-NC-SA 4.0](#)
- Figure 2.5: [“CO<sub>2</sub> emissions, in grams per mile, for a representative database of passenger vehicle trips in Southern California”](#) by Ramanathan et al. (2019) is under the following Creative Commons license: [CC BY-NC-SA 4.0](#)
- Figure 2.6: [“Emission-speed plot of individual trips or trip segments”](#) by Ramanathan et al. (2019) is under the following Creative Commons license: [CC BY-NC-SA 4.0](#)
- Figure 2.7: [“Possible use of traffic operation strategies in reducing on-road CO<sub>2</sub> emissions”](#) by

Ramanathan et al. (2019) is under the following Creative Commons license: [CC BY-NC-SA 4.0](#)

- Figure 2.8: [“General approach for calculating GHG emissions from transportation”](#) by Ramanathan et al. (2019) is under the following Creative Commons license: [CC BY-NC-SA 4.0](#)

## CHAPTER 3

- Figure 3.1: [Sharrows on US1 in West Palm Beach](#) by Michael Rivera is under the following Creative Commons license: [CC BY-SA 4.0](#)
- Figure 3.2: [Bike route along California State Highway 35](#) by Robert Ashworth is under the following Creative Commons license: [CC BY 2.0](#)
- Figure 3.3: [Bike lane on Pleasant Valley Parkway, Providence RI](#) by Kenneth C. Zirkel is under the following Creative Commons license: [CC BY-SA 4.0](#)
- Figure 3.4: [Bike route sign with directional information](#) by Richard Drdul is under the following Creative Commons license: [CC BY-SA 2.0](#)
- Figure 3.5: [Pandora cycle track 4](#) by Richard Drdul is under the following Creative Commons license: [CC BY-SA 2.0](#)
- Figure 3.6: [Protected intersection features](#) by Pierre Rouzeau via Wikimedia Commons is under the following Creative Commons license: [CC BY-SA 4.0](#)

## CHAPTER 5

- Figure 5.1: [Bending the Curve: Climate Change Solutions](#) by Ramanathan, V., Aines, R., Auffhammer, M., Barth, M., Cole, J., Forman, F., et al. is licensed under [CC BY-NC-SA 4.0](#)
- Figure 5.2: [Average passenger car GHG emissions normalized by distance traveled for different regions](#) by Ramanathan et al. (2019) is licensed under [CC BY-NC-SA 4.0](#)
- Figure 5.3: [The number of electric vehicles \(EVs\) being introduced for different regions](#) is licensed under [CC BY-NC-SA 4.0](#)
- Figure 5.4: [Fuel utilization for the US transportation market, 2018](#) is licensed under [CC BY-NC-SA 4.0](#)
- Table 5.1: [Greenhouse Gas Emissions per Kilometer, relative to Gasoline-Powered Internal Combustion Engines, Full Energy Cycle](#) by Ramanathan, V., Aines, R., Auffhammer, M., Barth, M., Cole, J., Forman, F., et al. is licensed under [CC BY-NC-SA 4.0](#)
- Figure 5.5: Modules of integrated traffic simulation and emission estimation. Produced with permission from the author Tanvir (2018).

## CHAPTER 6

- Figure 6.1: [Los Angeles 1943: Degraded Urban Air Quality](#) by Ramanathan et al. is licensed under [CC BY-NC-SA 4.0](#)
- Figure 6.2: [Combustion](#) by Ramanathan is licensed under [CC BY-NC-SA 4.0](#)



- Figure 6.3: [Combustion Impacts](#) by Ramanathan et al is licensed under [CC BY-NC-SA 4.0](#)
- Figure 6.4: [Power Generation Options](#) by Ramanathan is licensed under [CC BY-NC-SA 4.0](#)
- Figure 6.5: [Greenhouse Gas Emissions by Sector for 2016](#) by Analy Castillo is licensed under [CC BY-NC-SA 4.0](#)
- Figure 6.6: [Greenhouse Gas Emissions for the Transportation Sector in California](#) by Analy Casillo is licensed under [CC BY-NC-SA 4.0](#)

## CHAPTER 7

- Figure 7.1: [Conductive Charging- AC by Electric Cars: Technology](#) is licensed under [CC BY-NC-SA 4.0](#)
- Figure 7.2: [Conductive Charging- DC by Electric Cars: Technology](#) is licensed under [CC BY-NC-SA 4.0](#)
- Figure 7.3: [Inductive Charging- Static by Electric Cars: Technology](#) is licensed under [CC BY-NC-SA 4.0](#)
- Figure 7.4: [Inductive Charging- Dynamic by Electric Cars: Technology](#) is licensed under [CC BY-NC-SA 4.0](#)
- [Table 7.1](#) is licensed under [CC BY-NC-SA 4.0](#)
- Figure 7.5: [AC Charging Operations by Electric Cars: Technology](#) is licensed under [CC BY-NC-SA 4.0](#)
- [Table 7.2: Summary of Common Level 1 to Level 4 Charging Facilities in North America](#) is licensed under [CC BY 4.0](#)

## CHAPTER 8

- [Table 8.1: Intelligent transportation system applications utilizing connected and automated vehicle technology from “Bending the Curve: Climate Change Solutions”](#) by Ramanathan et al. is under the following Creative Commons license: [CC BY-NC-SA 4.0](#)
- [Figure 8.1: Potential energy/emissions impacts of automated technology from “Bending the Curve: Climate Change Solutions”](#) by Ramanathan et al. is under the following Creative Commons license: [CC BY-NC-SA 4.0](#)

## CHAPTER 9

- [Figure 9.1: A Systems Approach to Urban Distribution from Sustainable Urban Freight Transport: a Global Perspective](#) by through TU Delft OpenCourseWare is licensed under [Creative Commons Attribution Non-Commercial Share Alike](#)
- [Table 9.1: Overview of main actions public administrators can perform and potential reactions from the private sector](#) is adapted from Muñuzuri et al. 2005) [Adapted from Van Duin et al. (2019)]

## DERIVATIVE NOTES

---

Minor revisions not noted below include editing language for clarity, length, and flow as well as corrections to and additions of hyperlinks and citations. Other revisions not listed below include removing references to sections of the text that were not included in the book/article. The following is a chapter list of source material used in the creation of the text.

### CHAPTER 1

- [Sustainability: A Comprehensive Foundation](#) by Tom Theis and Jonathan Tomkin is Licensed under [CC BY 4.0](#)
- Foundations in Sustainability Systems (EME 504) by Neyda Abreu is licensed under [CC BY-NC-SA 4.0](#)

### CHAPTER 2

- [Bending the Curve: Climate Change Solutions](#) by Ramanathan, V., Aines, R., Auffhammer, M., Barth, M., Cole, J., Forman is licensed under [CC BY-NC-SA 4.0](#)
- [Climate Change and Transportation, Climate Change and Variability](#) by Yuri Yevdokimov is licensed under [CC BY-NC-SA-3.0](#)

### CHAPTER 4

- [Vibrant Sidewalks in the United States: Re-Integrating Walking and a Quintessential Social Realm](#) by Anastasia Loukaitou-Sideris and Renia Ehrenfeucht is licensed under [CC BY-NC 4.0](#)

### CHAPTER 5

- [Bending the Curve: Climate Change Solutions](#) by Ramanathan, V., Aines, R., Auffhammer, M., Barth, M., Cole, J., Forman, F., et al. is licensed under [CC BY-NC-SA 4.0](#)

### CHAPTER 6

- [Bending the Curve: Climate Change Solutions](#) by Ramanathan, V., Aines, R., Auffhammer, M., Barth, M., Cole, J., Forman, F., et al. is licensed under [CC BY-NC-SA 4.0](#)
- [Technology Mix Optimization for Zero-Emission Fleets Adopting a Multi-Criteria Decision Analysis within a Life Cycle Assessment Framework](#) by Castillo, Analy is licensed under [CC BY-NC-SA 4.0](#)
- [Viable Pathways in the Energy Sector to Meet California Climate Goals with an Emphasis on Heavy-Duty Transportation and Refinery Emissions](#) by Houck, Margaret is licensed under [CC BY-NC-SA 4.0](#)

## CHAPTER 7

- [Bending the Curve: Climate Change Solutions](#) by Ramanathan, V., Aines, R., Auffhammer, M., Barth, M., Cole, J., Forman, F., et al. is licensed under [CC BY-NC-SA 4.0](#)
- [Dynamic modeling and real-time management of a system of EV fast-charging stations](#) by Yang, D., Sarma, N., Hyland, M., & Jayakrishnan, R is licensed under [CC BY 4.0 Deed](#)
- [Electric Cars: Technology](#) by [TU Delft OpenCourseWare](#) is licensed under a [Creative Commons Attribution-NonCommercial-ShareAlike 4.0 International License](#).

## CHAPTER 8

- [Bending the Curve: Climate Change Solutions](#) by Ramanathan, V., Aines, R., Auffhammer, M., Barth, M., Cole, J., Forman, F., et al. is licensed under [CC BY-NC-SA 4.0](#)

## CHAPTER 9

- [Transforming the Freight Industry](#) in *ACCESS Magazine*, 1(20), 26-31 by Regan, A. is licensed by [CC BY-NC 3.0](#)
- [Sustainable Urban Freight Transport: a Global Perspective](#) by [Dr. J.H.R. van Duin](#), [Dr. Johan Joubert](#), [Dr. Russell Thompson](#), [Ir. Tharsis Teoh](#), [Prof.dr.ir. L.A. Tavasszy](#) through TU Delft OpenCourseWare is licensed under [Creative Commons Attribution Non-Commercial Share Alike](#)

## ERRATA AND VERSIONING HISTORY

---

### MAVS OPEN PRESS

The peer review process for Mavs Open Press resources varies by publication and author. We strive for transparency and describe the creation process in the front matter of each text so readers may evaluate the work on its own merit. Because we offer web-based services, we can quickly and easily address any errors that arise after publication. This page provides a record of edits and changes made to the web version of this book since its initial publication.

Changes logged here are reflected in the web text only until a new version of the resource is released, at which point the file downloads are also updated. Version updates are noted in the Status field below.

If you have a correction to suggest, submit it to [oyer@uta.edu](mailto:oyer@uta.edu). We will contact the author then make and log necessary changes here. Below is a list of Correction Types we currently update:

1. Typo
2. Broken link
3. Addition
4. Other factual inaccuracy in content
5. Incorrect calculation or solution
6. General/pedagogical suggestion or question

Date Submitted	Format	Correction Type	Location	Description	Status